



## **REQUEST FOR QUOTATIONS**

**Title:** **Street Banner and Seasonal Lighting  
Installation and Maintenance**

**Reference No.:** 1220-040-2017-035

**FOR THE SUPPLY OF GOODS AND SERVICES**

(General Services)

## TABLE OF CONTENTS

1. INTRODUCTION.....	3
2. ADDRESS FOR DELIVERY.....	3
3. DATE .....	3
4. INQUIRIES.....	4
5. ADDENDA .....	4
6. NO CONTRACT .....	4
7. ACCEPTANCE.....	4
8. CONTRACTOR'S EXPENSES.....	4
9. CONTRACTOR'S QUALIFICATIONS .....	5
10. CONFLICT OF INTEREST .....	5
11. SOLICITATION OF COUNCIL MEMBERS, CITY STAFF AND CITY CONSULTANTS.....	5
12. CONFIDENTIALITY .....	5
13. SIGNATURE .....	5
14. MULTIPLE CONTRACTORS .....	6
ATTACHMENT 1 – DRAFT QUOTATION AGREEMENT .....	7
SCHEDULE A – SPECIFICATIONS OF GOODS AND SCOPE OF SERVICES .....	25
SCHEDULE B – QUOTATION .....	38

## REQUEST FOR QUOTATIONS

### 1. INTRODUCTION

The City of Surrey (the "City") invites contractors to provide a quotation on the form attached as Schedule B to Attachment 1 (the "Quotation") for the supply of the goods (if any) and/or services described in Schedule A to Attachment 1 (the "Goods and Services"). The description of the Goods and Services sets out the minimum requirements of the City. A person that submits a Quotation (the "Contractor") should prepare a Quotation that meets the minimum requirements, and may as it may choose, in addition, also include goods, services or terms that exceed the minimum requirements.

### 2. ADDRESS FOR DELIVERY

A Quotation should be labelled with the Contractor's name, RFQ title and number. A Quotation should be submitted in the form attached to this RFQ as Schedule B – Quotation.

The Contractor may submit a Quotation either by email or in a hard copy, as follows:

#### (a) Email

If the Contractor chooses to submit by email, the Contractor should submit the Quotation electronically in a single pdf file to the City by email at: [purchasing@surrey.ca](mailto:purchasing@surrey.ca)

PDF emailed Quotations are preferred and the City will confirm receipt of emails. Note that the maximum file size the City can receive is 10Mb. If sending large email attachments, Contractors should phone to confirm receipt. A Contractor bears all risk that the City's equipment functions properly so that the City receives the Quotation.

#### (b) Hard Copy

If the Contractor chooses NOT to submit by email, the Contractor should submit one original unbound Quotation and one (1) copy, (two (2) in total) which should be delivered to the City at the office of:

Name: Richard D. Oppelt, Purchasing Manager  
at the following location:

Address: Surrey City Hall  
Finance & Technology Department – Purchasing Section  
Reception Counter, 5<sup>th</sup> Floor West  
13450 – 104 Avenue, Surrey, B.C., Canada, V3T 1V8

### 3. DATE

The City would prefer to receive Quotations on or before **March 8, 2017**. The City's office hours are 8:30 a.m. to 4:00 p.m., Monday to Friday, except statutory holidays.

#### 4. INQUIRIES

All inquiries related to this RFQ should be directed in writing to the person named below (the “**City Representative**”). Information obtained from any person or source other than the City Representative may not be relied upon.

Name: Richard D. Oppelt, Purchasing Manager  
E-mail: [purchasing@surrey.ca](mailto:purchasing@surrey.ca)  
Reference: 1220-040-2017-035

#### 5. ADDENDA

If the City determines that an amendment is required to this RFQ, the City’s Representative will issue a written addendum by posting it on the BC Bid Website at [www.bcbid.gov.bc.ca](http://www.bcbid.gov.bc.ca) (the “**BC Bid Website**”) and the City Website at [www.surrey.ca](http://www.surrey.ca) (the “**City Website**”) that will form a part of this RFQ. It is the responsibility of Contractor to check the BC Bid Website and the City Website for addenda. The only way this RFQ may be added to, or amended in any way, is by a formal written addendum. No other communication, whether written or oral, from any person will affect or modify the terms of this RFQ or may be relied upon by any Contractor. By delivery of a Quotation, the Contractor is deemed to have received, accepted and understood the entire RFQ, including any and all addenda.

#### 6. NO CONTRACT

This RFQ is simply an invitation for quotations (including prices and terms) for the convenience of all parties. It is not a tender and no obligations of any kind will arise from this RFQ or the submission of Quotations. The City may negotiate changes to any terms of a Quotation, including terms in Attachment 1 and Schedules A and B and including prices, and may negotiate with one or more Contractors or may at any time invite or permit the submission of quotations (including prices and terms) from other parties who have not submitted Quotations.

#### 7. ACCEPTANCE

A Quotation will be an offer to the City which the City may accept at any time by signing the copy of the Quotation and delivering it to the Contractor. A Quotation is not accepted by the City unless and until both the authorized signatory of the Contractor and the authorized signatory of the City have signed. Delivery of the signed Agreement by the City may be by fax or pdf e-mail or hard copy. In that event, the contract will be comprised of the documents included in the definition of Agreement in Attachment No. 1 – Quotation Agreement – Goods and Services.

#### 8. CONTRACTOR'S EXPENSES

Contractors are solely responsible for their own expenses in preparing and submitting Quotations, and for any meetings, negotiations or discussions with the City or its representatives and consultants, relating to or arising from the RFQ. The City will not be liable to any Contractor for any claims, whether for costs, expenses, losses or damages, or loss of anticipated profits, incurred by the Contractor in preparing and submitting a

Quotation, or participating in negotiations for a contract, or other activity related to or arising out of this RFQ.

**9. CONTRACTOR'S QUALIFICATIONS**

By submitting a Quotation, a Contractor represents that it has the expertise, qualifications, resources, and relevant experience to supply the Goods and Services.

**10. CONFLICT OF INTEREST**

A Contractor must disclose in its Quotation any actual or potential conflicts of interest and existing business relationships it may have with the City, its elected or appointed officials or employees. The City may rely on such disclosure.

**11. SOLICITATION OF COUNCIL MEMBERS, CITY STAFF AND CITY CONSULTANTS**

Contractors and their agents will not contact any member of the City Council, City staff or City consultants with respect to this RFQ, other than the contact person named in Section 4, at any time prior to the award of a contract or the cancellation of this RFQ.

**12. CONFIDENTIALITY**

All Quotations become the property of the City and will not be returned to the Contractor. All Quotations will be held in confidence by the City unless otherwise required by law. Contractors should be aware the City is a "public body" defined by and subject to the *Freedom of Information and Protection of Privacy Act* of British Columbia.

**13. SIGNATURE**

The legal name of the person or firm submitting the Quotation should be inserted in the Quotation. The Quotation should be signed by a person authorized to sign on behalf of the Contractor and include the following:

- (a) If the Contractor is a corporation then the full name of the corporation should be included, together with the names of authorized signatories. The Quotation should be executed by all of the authorized signatories or by one or more of them provided that a copy of the corporate resolution authorizing those persons to execute the Quotation on behalf of the corporation is submitted;
- (b) If the Contractor is a partnership or joint venture then the name of the partnership or joint venture and the name of each partner or joint venturer should be included, and each partner or joint venturer should sign personally (or, if one or more person(s) have signing authority for the partnership or joint venture, the partnership or joint venture should provide evidence to the satisfaction of the City that the person(s) signing have signing authority for the partnership or joint venture). If a partner or joint venturer is a corporation then such corporation should sign as indicated in subsection (a) above; or
- (c) If the Contractor is an individual, including a sole proprietorship, the name of the individual should be included.

**15. MULTIPLE CONTRACTORS**

The City reserves the right and discretion to divide up the Goods and Services, either by scope, geographic area, or other basis as the City may decide, and to select one or more Contractors to enter into discussions with the City for one or more Contracts to perform a portion or portions of the Goods and Services. If the City exercises its discretion to divide up the Goods and Services, the City will do so reasonably having regard for the RFQ and the basis of Quotations.

In addition to any other provision of this RFQ, Quotations may be evaluated on the basis of advantages and disadvantages to the City that might result or be achieved from the City dividing up the Goods and Services and entering into one or more Contracts with one or more Contractors.

**-END OF PAGE-**

**ATTACHMENT 1**



**DRAFT QUOTATION AGREEMENT**

**Title:** **Street Banner and Seasonal Lighting  
Installation and Maintenance**

**Reference No.:** 1220-040-2017-035

**FOR THE SUPPLY OF GOODS AND SERVICES**

## TABLE OF CONTENTS

### DRAFT QUOTATION AGREEMENT – GOODS AND SERVICES

1.	DEFINITIONS AND INTERPRETATION .....	9
2.	GOODS AND SERVICES .....	10
3.	TERM .....	11
4.	TIME .....	11
5.	FEES .....	11
6.	PAYMENT .....	12
7.	USE OF WORK PRODUCT .....	13
8.	PERSONNEL AND SUBCONTRACTORS.....	13
9.	LIMITED AUTHORITY .....	14
10.	CONFIDENTIALITY AND DISCLOSURE OF INFORMATION .....	14
11.	WARRANTIES.....	15
12.	INSURANCE AND DAMAGES.....	15
13.	CITY RESPONSIBILITIES .....	17
14.	DEFICIENCIES.....	17
15.	DEFAULT AND TERMINATION.....	17
16.	CURING DEFAULTS .....	18
17.	DISPUTE RESOLUTION .....	19
18.	WCB AND OCCUPATIONAL HEALTH AND SAFETY .....	19
19.	BUSINESS LICENSE.....	20
20.	GENERAL PROVISIONS FOR GOODS .....	20
21.	COMPLIANCE .....	21
22.	JURISDICTION OF COUNCIL AND NON-APPROPRIATION.....	21
23.	WAIVER.....	21
24.	APPLICABLE LAW .....	22
25.	NOTICES.....	22
26.	MERGER AND SURVIVAL .....	22
27.	ENTIRE AGREEMENT .....	22
28.	SIGNATURE .....	22
29.	FUEL EMISSIONS DATA .....	23
30.	NON ROAD DIESEL ENGINE EMISSION REGULATION .....	23
31.	ENUREMENT .....	24
	SCHEDULE A – SPECIFICATIONS OF GOODS AND SCOPE OF SERVICES .....	25
	SCHEDULE B – QUOTATION .....	38



## DRAFT QUOTATION AGREEMENT – GOODS AND SERVICES

Reference RFQ Title: Street Banner and Seasonal Lighting Installation and Maintenance

**THIS AGREEMENT** dated for reference this \_\_\_\_\_ day of \_\_\_\_\_, 201\_.

AGREEMENT No.: 1220-040-2017-035

### BETWEEN:

**CITY OF SURREY**  
13450 - 104 Avenue  
Surrey, B.C., Canada, V3T 1V8  
(the "**City**")

### AND:

\_\_\_\_\_  
(*Insert Full Legal Name and Address of Contractor*)

(the "**Contractor**")

**WHEREAS** the City wishes to engage the Contractor to provide Goods and Services and the Contractor agrees to provide Goods and Services.

**THEREFORE** in consideration of the payment of one (\$1.00) dollar and other good and valuable consideration paid by each of the parties to the other (the receipt and sufficiency of which is hereby acknowledged) the City and the Contractor agree as follows:

## 1. DEFINITIONS AND INTERPRETATION

### 1.1 In these General Terms and Conditions:

- (a) "**Agreement**" means this agreement and all schedules attached hereto;
- (b) "**Calendar Year**" means the time period from January 1st to December 31st;
- (c) "**City**" means the City of Surrey;
- (d) "**Contractor**" means a contractor whose Quotation has been accepted by the City and who is providing the Goods and Services under this Agreement;
- (e) "**Disbursements**" means the actual out-of-pocket costs and expenses as identified in Section B to Attachment 1, which the Contractor incurs in providing the Goods and Services;
- (f) "**Fees**" means the price set out in Section B to Attachment 1, for the provision of the Goods and Services, unless otherwise agreed by the parties in writing, and includes all taxes;
- (g) "**Goods**" means the equipment or materials (if any) as described generally in Schedule A, to Attachment 1, including anything and everything required to be done for the fulfilment and completion of this Agreement;
- (h) "**Indemnitees**" has the meaning described in Section 11.2;
- (i) "**RFQ**" means the Request for Quotations;

- (j) **“Services”** means the services as described generally in Schedule A, to Attachment 1 including anything and everything required to be done for the fulfilment and completion of this Agreement;
- (k) **“Term”** has the meaning described in Section 3.1; and
- (l) **“Year of the Term”** as used herein shall mean each twelve-month period commencing on (April 1, 2017).

- 1.2 This Agreement may be modified only by express and specific written agreement. In the event of a conflict between the provisions of any documents listed below, then the documents shall govern and take precedence in the following order:
- (a) this Agreement;
  - (b) Addenda (if any);
  - (c) the RFQ; and
  - (d) other terms, if any, that are agreed to by the parties in writing.

- 1.3 The following attached Schedules are a part of this Agreement:

Schedule A Specifications of Goods & Scope of Services;  
Schedule A-1 Banner Pole List of Locations;  
Schedule A-2 Banner Pole Maps;  
Schedule A-3 Banner Specifications & Dimensions;  
Schedule A-4 Pole Features;  
Schedule A-5 Seasonal Light Trees Features;

Appendix 1 Prime Contractor Designation – Letter of Understanding;  
Appendix 2 Contractor Health & Safety Expectation – Responsibility of Contractors; and

Schedule B – Quotation.

## **2. GOODS AND SERVICES**

- 2.1 The Contractor covenants and agrees with the City to provide the Goods and Services in accordance with this Agreement. The Goods and Services provided will meet the specifications and scope set out in Schedule A, to Attachment 1, and as described in Schedule B, to Attachment 1.
- 2.2 The City may from time to time, by written notice to the Contractor, make changes in the specifications of Goods and scope of Services. The Fees will be increased or decreased by written agreement of the City and the Contractor according to the rates set out in Schedule B, to Attachment 1.
- 2.3 The Contractor will, if required in writing by the City, provide additional goods or services. The terms of this Agreement will apply to any additional goods or services, and the fees for additional goods or services will generally correspond to the fees as described in Schedule B, to Attachment 1. The Contractor will not provide any additional goods or services in excess of the specification of Goods and scope of Services requested in writing by the City.
- 2.4 The Contractor will perform the Services with that degree of care, skill and diligence normally provided by a qualified and experienced practitioner performing services similar to the Services, and on the understanding that the City is relying on the Contractor's

experience and expertise. The Contractor represents that it has the expertise, qualifications, resources, and relevant experience to supply the Goods and Services.

- 2.5 The Contractor will deliver the Goods free and clear of all liens and encumbrances in the manner and to the destination stipulated. In the event of the Contractor's failure to meet this condition, the Contractor will, on written notice from the City, forthwith return all monies paid by the City on account of the Goods and in addition the City may by written notice terminate this Agreement without liability, and in such event, in addition to the above, the Contractor will be liable for any and all expenses or losses incurred by the City resulting from such failure.

### **3. TERM**

- 3.1 The Contractor will provide the Goods and Services for the period commencing on April 1, 2017 and terminating on March 30, 2018 (the "**Term**").
- 3.2 The City may at any time prior to thirty (30) days before the end of the Term, by written notice to the Contractor, extend the Term for a period of time not to exceed two (2) one year renewal terms. If the City elects to extend the Term, the provisions of this Agreement will remain in force, including the Fees, except where amended in writing by the parties.

### **4. TIME**

- 4.1 The Contractor acknowledges that time is of the essence with respect to the provision of the Services and accordingly the Contractor will provide the Services within the performance or completion dates or time periods [the "**Time Schedule**"] as agreed to in writing by the City and the Contractor. If at any time the Contractor discovers that the Time Schedule cannot be met it will immediately advise the City in writing and propose a revised Time Schedule for approval by the City representative.

### **5. FEES**

- 5.1 The City will pay the Fees to the Contractor in accordance with this Agreement. Payment by the City of the Fees will be full payment for the Goods and Services and the Contractor will not be entitled to receive any additional payment from the City.
- 5.2 For greater certainty, costs of general management, non-technical supporting services and general overhead are deemed to be covered by the Fees and will not be subject to additional payment by the City. The Fees shall also include without limitation all costs of boxing, packing, crating, and loading and unloading the Goods at the prescribed destination.
- 5.3 The parties agree that all fees as set out in this Agreement will remain in force for a period of twelve] (12) months and thereafter the fees will be subject to an increase during the term once per Year of the Term by a percentage which shall not be greater than the percentage increase in the Consumer Price Index (All items) for Vancouver, British Columbia as published by Statistics Canada ("**CPI**"), or any successor government agency for the Calendar Year immediately preceding the applicable January 1st of the current Calendar Year.

## 6. PAYMENT

- 6.1 Subject to any contrary provisions set out in Schedule B, to Attachment 1, the Contractor will submit invoice to the City requesting payment of the portion of the Fees relating to the Goods and Services provided. Invoices must include the Contractor's name, address and telephone number, the City's purchase order number **<☒ insert purchase order or contract reference number>** , the Contractor's invoice number, the names, charge-out rates and number of hours worked of all employees of the Contractor that have performed Services; the percentage of Services completed and Goods delivered; the total budget for the Goods and Services and the amount of the budget expended to the date of the invoice; taxes (if any); and grand total of the invoice.
- 6.2 If the City reasonably determines that any portion of an invoice is not payable, then the City will so advise the Contractor.
- 6.3 The City will pay the portion of an invoice which the City determines is payable within 30 days of the receipt of the Invoice, except the City may hold back from payments 10% of the amount the City determines is payable to the Contractor until such time as the Contractor provides its final report to the City; and
- 6.4 If the Contractor offers the City a cash discount for early payment, then the City may, at the City's sole discretion, pay the portion of an Invoice which the City determines is payable at any time after receipt of the Invoice.
- 6.5 In an effort to support sustainability, reduce risk and improve customer service, the City has introduced an electronic fund transfer (EFT) option for Contractors. Electing to participate in this program will allow Contractors to receive their payments directly into their bank accounts, reducing risk of fraud and improving the timeliness of their payment receipt.
- 6.6 To receive your payments electronically, fax your request on company letterhead to 604-591-4488. You may contact us at 604-592-7010 (Accounts Payable General Inquiries) for more information.

### **SUBMITTING YOUR ELECTRONIC INVOICE**

Please send electronic invoices to the City of Surrey by email to [surreyinvoices@surrey.ca](mailto:surreyinvoices@surrey.ca)

In order to process your payment, the following submission guidelines **must** be met:

- Invoice(s) must be sent as attachments.
- Attachment(s) must be in PDF format.
- PDF attachment(s) must be named: <Company name>\_<Invoice Number>.
- Email(s) must not exceed 2MB.

**Please Note:** failure to meet the guidelines above may result in payment processing delays or in your payment not being processed.

## **SUBMITTING YOUR INVOICE BY HARD COPY**

Mail hard copy invoices to:

Surrey City Hall – Accounts Payable  
13450 – 104 Avenue  
Surrey, B.C., Canada, V3T 1V8

- Submit only invoices to this address.
- Submit any supporting documents to your City of Surrey business contact.
- Don't send duplicate hard copy or soft-copy invoices in any manner. Should a need arise to submit an invoice copy, ensure it is clearly labeled COPY.
- Incomplete invoices will be returned.

6.7 Unless otherwise provided, all dollar amounts referred to in this Agreement are in lawful money of Canada.

6.8 If the Contractor is a non-resident of Canada and does not provide to the City a waiver of regulation letter, the City will withhold and remit to the appropriate governmental authority the greater of:

- (a) 15% of each payment due to the Contractor; or
- (b) the amount required under applicable tax legislation.

## **7. USE OF WORK PRODUCT**

7.1 The Contractor hereby sells, assigns and transfers to the City the right, title and interest required for the City to use and receive the benefit of all the reports, drawings, plans, designs, models, specifications, computer software, concepts, products, designs or processes or other such work product produced by or resulting from the Services rendered by the Contractor. This section does not give the City the right to sell any such work product to any third party and the City may sell the work product only with the prior approval of the Contractor. The Contractor may retain copies of the work product.

## **8. PERSONNEL AND SUBCONTRACTORS**

8.1 The Contractor will provide only personnel who have the qualifications, experience and capabilities to provide the Goods and perform the Services.

The Contractor will ensure that:

- (a) all personnel performing the Services conduct themselves in a courteous and respectful manner that is conducive to positive public relations;
- (b) all personnel will wear a uniform provided by the Contractor in a form satisfactory to the Department Representative and that abides by all clothing requirements under the *Workers Compensation Act* and Regulations pursuant thereto; and
- (c) all personnel will at all times carry on their person, personal photographic identification.

- 8.2 The Contractor will provide the Goods and Services using the personnel and sub-contractors as may be listed in the Quotation, and the Contractor will not remove any such listed personnel or sub-contractors from the Services without the prior written approval of the City.
- 8.3 If the City reasonably objects to the performance, qualifications, experience or suitability of any of the Contractor's personnel or sub-contractors then the Contractor will, on written request from the City, replace such personnel or sub-contractors.
- 8.4 Except as provided for in Section 8.2, the Contractor will not engage any personnel or sub-contractors, or sub-contract or assign its obligations under this Agreement, in whole or in part, without the prior written approval of the City.
- 8.5 The Contractor will preserve and protect the rights of the City with respect to any Services performed under sub-contract and incorporate the conditions of this Agreement into all sub-contracts as necessary to preserve the rights of the City under this Agreement. The Contractor will be as fully responsible to the City for acts and omissions of sub-contractors and of persons directly or indirectly employed by them as for acts and omissions of persons directly employed by the Contractor.

## **9. LIMITED AUTHORITY**

- 9.1 The Contractor is not and this Agreement does not render the Contractor an agent or employee of the City, and without limiting the above, the Contractor does not have authority to enter into any contract or reach any agreement on behalf of the City, except for the limited purposes as may be expressly set out in this Agreement, or as necessary in order to provide the Goods and Services. The Contractor will make such lack of authority clear to all persons with whom the Contractor deals in the course of providing the Goods and Services. Every vehicle used by the Contractor in the course of providing the Goods and Services shall identify the Contractor by name and telephone number.
- 9.2 The Contractor is an independent contractor. This Agreement does not create the relationship of employer and employee, a partnership, or a joint venture. The City will not control or direct the details, means or process by which the Contractor performs the Services. The Contractor will determine the number of days and hours of work required to properly and completely perform the Services. The Contractor is primarily responsible for performance of the Goods and Services and may not delegate or assign any Services to any other person except as provided for in section 8.4. The Contractor will be solely liable for the wages, fringe benefits, work schedules and work conditions of any partners, employees or sub-contractors.

## **10. CONFIDENTIALITY AND DISCLOSURE OF INFORMATION**

- 10.1 Except as provided for by law or otherwise by this Agreement, the Contractor will keep strictly confidential any information supplied to, obtained by, or which comes to the knowledge of the Contractor as a result of the provision of the Goods or performance of the Services and this Agreement, and will not, without the prior express written consent of the City, publish, release, disclose or permit to be disclosed any such information to any person or corporation, either before, during or after termination of this Agreement, except as reasonably required to complete the Goods and Services.

- 10.2 The Contractor acknowledges that the City is subject to the *Freedom of Information and Protection of Privacy Act* of British Columbia and agrees to any disclosure of information by the City required by law.
- 10.3 The Contractor agrees to return to the City all of the City's property at the completion of this Agreement, including any and all copies or originals of reports provided by the City.

## **11. WARRANTIES**

- 11.1 The Contractor warrants that the Goods shall be free from defects in design, materials, workmanship and title, shall conform in all respects to the terms of this Agreement, shall be fit and suitable and perform satisfactorily for the purposes and under the conditions made known to the Contractor by the City or which were reasonably inferable. The Goods shall be at least equal to the higher of national standards or codes (such as, by way of illustration, CSA or ASTM), or standards and codes customarily applicable at the place where the City will use the Goods. The Goods shall be of the best quality, if no quality is specified. This general warranty is independent of and without prejudice to any specific warranty or service guarantee offered by the Contractor or third party manufacturer or supplier of the Goods in connection with the purpose for which the Goods were purchased. The Contractor shall assign to the City any warranty or service guarantee offered by a third party manufacturer or supplier of the Goods. Notwithstanding this assignment, if at any time up to one year from the date of delivery or installation (if applicable) the City determines the Goods or any part do not conform to these warranties, the City shall notify the Contractor within a reasonable time after such discovery, and the Contractor shall then promptly correct such nonconformity at the Contractor's expense. Goods used to correct a nonconformity shall be similarly warranted for one year from the date of installation. The Contractor's liability shall extend to all liabilities, losses, damages, claims and expenses incurred by the City caused by any breach of any of the above warranties.
- 11.2 The Contractor warrants and guarantees that Goods and Services delivered under this Agreement do not infringe any valid patent, copyright or trademark, foreign or domestic, owned or controlled by any other corporation, firm or person, and agrees to indemnify and save harmless the City and all of its elected and appointed officials, officers, employees, servants, representatives and agents (collectively the "**Indemnitees**"), from and against any and all claims, demands, causes of action, suits, losses, damages and costs, liabilities, expenses and judgments (including all actual legal costs) by reason of any claim, action or litigation arising out of any alleged or actual infringement of any patent, copyright or trademark, foreign or domestic, relating to the Goods and Services supplied under this Agreement.

## **12. INSURANCE AND DAMAGES**

- 12.1 The Contractor will indemnify and save harmless the Indemnitees from and against all claims, demands, causes of action, suits, losses, damages and costs, liabilities, expenses and judgments (including all actual legal costs) for damage to or destruction or loss of property, including loss of use, and injury to or death of any person or persons which any of the Indemnitees incur, suffer or are put to arising out of or in connection with any failure, breach or non-performance by the Contractor of any obligation of this Agreement, or any wrongful or negligent act or omission of the Contractor or any employee or agent of the Contractor.

- 12.2 The indemnities described in Sections 11.2, 12.1 and 18.3 will survive the termination or completion of this Agreement and, notwithstanding such termination or completion, will continue in full force and effect for the benefit of the Indemnitees.
- 12.3 The Contractor will, without limiting its obligations or liabilities and at its own expense, provide and maintain throughout this Agreement the following insurances in forms and amounts acceptable to the City from insurers licensed to conduct business in Canada:
- (a) commercial general liability insurance on an occurrence basis, in an amount not less than five million (\$5,000,000) dollars inclusive per occurrence against death, bodily injury and property damage arising directly or indirectly out of the work or operations of the Contractor, its employees and agents. The insurance will include cross liability and severability of interests such that the coverage shall apply in the same manner and to the same extent as though a separate policy had been issued to each insured. The insurance will include, but not be limited to: premises and operators liability, broad form products and completed operations, owners and contractors protective liability, blanket contractual, employees as additional insureds, broad form property damage, non-owned automobile, contingent employers liability, broad form loss of use, personal injury, and incidental medical malpractice. The City will be added as additional insured;
  - (b) automobile liability insurance on all vehicles owned, operated or licensed in the name of the Contractor in an amount not less than three million (\$3,000,000) dollars per occurrence for bodily injury, death and damage to property; and
  - (c) contractors' equipment insurance in an all risks form covering construction machinery and equipment used for the performance of the Services.
- 12.4 The Contractor will provide the City with evidence of the required insurance prior to the commencement of this Agreement. Such evidence will be in the form of a completed certificate of insurance acceptable to the City. The Contractor will, on request from the City, provide certified copies of all of the Contractor's insurance policies providing coverage relating to the Services, including without limitation any professional liability insurance policies. All required insurance will be endorsed to provide the City with thirty (30) days advance written notice of cancellation or material change restricting coverage. To the extent the City has an insurable interest, the builder's risk policy will have the City as first loss payee. The Contractor will be responsible for deductible amounts under the insurance policies. All of the Contractor's insurance policies will be primary and not require the sharing of any loss by the City or any insurer of the City.
- 12.5 The Contractor acknowledges that any requirement by the City as to the amount of coverage under any policy of insurance will not constitute a representation by the City that the amount required is adequate and the Contractor acknowledges and agrees that the Contractor is solely responsible for obtaining and maintaining policies of insurance in adequate amounts. The insurance policy coverage limits shall not be construed as relieving the Contractor from responsibility for any amounts which may exceed these limits, for which the Contractor may be legally liable.
- 12.6 The Contractor shall place and maintain, or cause any of its sub-contractors to place and maintain, such other insurance or amendments to the foregoing policies as the City may reasonably direct.
- 12.7 The Contractor hereby waives all rights of recourse against the City for loss or damage to the Contractor's property.



### **13. CITY RESPONSIBILITIES**

- 13.1 The City will, in co-operation with the Contractor, make efforts to make available to the Contractor information, surveys, and reports which the City has in its files and records that relate to the Goods and Services. The Contractor will review any such material upon which the Contractor intends to rely and take reasonable steps to determine if that information is complete or accurate. The Contractor will assume all risks that the information is complete and accurate and the Contractor will advise the City in writing if in the Contractor's judgment the information is deficient or unreliable and undertake such new surveys and investigations as are necessary.
- 13.2 The City will in a timely manner make all decisions required under this Agreement, examine documents submitted by the Contractor and respond to all requests for approval made by the Contractor pursuant to this Agreement.
- 13.3 If the City observes or otherwise becomes aware of any fault or defect in the delivery of Goods or the provision of Services, it may notify the Contractor, but nothing in this Agreement will be interpreted as giving the City the obligation to inspect or review the Contractor's performance with regards to delivering Goods or the performance of the Services.

### **14. DEFICIENCIES**

- 14.1 The City shall have a reasonable time to inspect and to accept the Goods and Services. The City may reject any Goods or Services not in accordance with this Agreement, whether due to damage resulting from improper packing, loading, unloading or otherwise. The City shall notify the Contractor of rejection of the Goods whereupon the Goods will be held subject to the disposition by the Contractor. Any costs or expenses incurred by the City as a result of the rejection of the Goods or Services are, immediately upon written demand by the City, payable by the Contractor, and may be set off against any payments owing by the City to the Contractor.
- 14.2 The City may hold back from payments otherwise due to the Contractor up to 150% of a reasonable estimate, as determined by the City, on account of deficient or defective Goods or Services. This holdback may be held, without interest, until replacement Goods are received or such deficiency or defect is remedied.

### **15. DEFAULT AND TERMINATION**

- 15.1 In the event the Contractor does not deliver the Goods or perform the Services by the date specified in this Agreement, then:
- (a) the City reserves the right to terminate this Agreement, in whole or in part, and in the event of such termination no payment will be owing by the City on account of this Agreement and the Contractor will be liable for any and all expenses or loss resulting from such failure or delay and will return all monies paid by the City; or
  - (b) if the City does not terminate this Agreement for late delivery or performance, the City may deduct and setoff from any payments owing to the Contractor all additional costs the City reasonably incurs on account of the late delivery or performance.

- 15.2 The City may by written notice at any time cancel this Agreement with respect to Goods which, as of the date of cancellation, have not been shipped.
- 15.3 The City may at any time and for any reason by written notice to the Contractor terminate this Agreement before the completion of all the Goods and Services, such notice to be determined by the City at its sole discretion. Upon receipt of such notice, the Contractor will perform no further Goods and Services other than the work which is reasonably required to complete the Goods and Services. Despite any other provision of this Agreement, if the City terminates this Agreement before the completion of all the Goods and Services, the City will pay to the Contractor all amounts owing under this Agreement for Goods and Services provided by the Contractor up to and including the date of termination, plus reasonable termination costs in the amount as determined by the City in its sole discretion. Upon payment of such amounts no other or additional payment will be owed by the City to the Contractor, and, for certainty, no amount will be owing on account of lost profits relating to the portion of the Goods and Services not performed or other profit opportunities.
- 15.4 The City may terminate this Agreement for cause as follows:
- (a) If the Contractor is adjudged bankrupt, or makes a general assignment for the benefit of creditors because of its insolvency, or if a receiver is appointed because of its insolvency, the City may, without prejudice to any other right or remedy the City may have, terminate this Agreement by giving the Contractor or receiver or trustee in bankruptcy written notice; or
  - (b) If the Contractor is in breach of any term or condition of this Agreement, and such breach is not remedied to the reasonable satisfaction of the City within 5 days after delivery of written notice from the City to the Contractor, then the City may, without prejudice to any other right or remedy the City may have, terminate this Agreement by giving the Contractor further written notice.
- 15.5 If the City terminates this Agreement as provided by Section 15.4 then the City may:
- (c) enter into contracts, as it in its sole discretion sees fit, with other persons to complete the Goods and Services;
  - (d) withhold payment of any amount owing to the Contractor under this Agreement for the performance of the Goods and Services;
  - (e) set-off the total cost of completing the Goods and Services incurred by the City against any amounts owing to the Contractor under this Agreement, and at the completion of the Goods and Services pay to the Contractor any balance remaining; and
  - (f) if the total cost to complete the Goods and Services exceeds the amount owing to the Contractor, charge the Contractor the balance, which amount the Contractor will forthwith pay.

## **16. CURING DEFAULTS**

- 16.1 If the Contractor is in default of any of its obligations under this Agreement, then the City may without terminating this Agreement, upon 5 days written notice to the Contractor, remedy the default and set-off all costs and expenses of such remedy against any amounts owing to the Contractor. Nothing in this Agreement will be interpreted or construed to mean that the City has any duty or obligation to remedy any default of the Contractor.

## **17. DISPUTE RESOLUTION**

- 17.1 The parties will make reasonable efforts to resolve any dispute, claim, or controversy arising out of this Agreement or related to this Agreement (“**Dispute**”) using the dispute resolution procedures set out in this section.
- 17.2 Negotiation: The parties will make reasonable efforts to resolve any Dispute by amicable negotiations and will provide frank, candid and timely disclosure of all relevant facts, information and documents to facilitate negotiations.
- 17.3 Mediation: If all or any portion of a Dispute cannot be resolved by good faith negotiations within 30 days, either party may by notice to the other party refer the matter to mediation. Within 7 days of delivery of the notice, the parties will mutually appoint a mediator. If the parties fail to agree on the appointment of the mediator, then either party may apply to the British Columbia International Commercial Arbitration Centre for appointment of a mediator. The parties will continue to negotiate in good faith to resolve the Dispute with the assistance of the mediator. The place of mediation will be Surrey, British Columbia. Each party will equally bear the costs of the mediator and other out-of-pocket costs, and each party will bear its own costs of participating in the mediation.
- 17.4 Litigation: If within 90 days of the request for mediation the Dispute is not settled, or if the mediator advises that there is no reasonable possibility of the parties reaching a negotiated resolution, then either party may without further notice commence litigation.

## **18. WCB AND OCCUPATIONAL HEALTH AND SAFETY**

- 18.1 The Contractor agrees that it shall, at its own expense, procure and carry, or cause to be procured, carried and paid for, full Workers' Compensation Board coverage for itself and all workers, employees, servants and others engaged in or upon any work or service which is the subject of this Agreement. The Contractor agrees that the City has the unfettered right to set off the amount of the unpaid premiums and assessments for the Workers' Compensation Board coverage against any monies owing by the City to the Contractor. The City shall have the right to withhold payment under this Agreement until the Workers' Compensation Board premiums, assessments or penalties in respect of the work done or service performed in fulfilling this Agreement have been paid in full.
- 18.2 The Contractor shall provide the City with the Contractor's Workers' Compensation Board registration number and a letter from the Workers' Compensation Board confirming that the Contractor is registered in good standing with the Workers' Compensation Board and that all assessments have been paid to the date thereof prior to the City having any obligations to pay monies under this Agreement.
- 18.3 Without limiting the generality of any other indemnities granted by the Contractor in this Agreement, the Contractor shall indemnify and hold harmless the City, its elected and appointed officials, employees and agents, from all manner of claims, demands, costs, losses, penalties and proceedings (including all actual legal costs) arising out of or in any way related to unpaid Workers' Compensation Board assessments owing from any person or corporation engaged in the performance of this Agreement or arising out of or in any way related to the failure to observe safety rules, regulations and practices of the Workers' Compensation Board, including penalties levied by the Workers' Compensation Board.

- 18.4 The Contractor agrees that it is the “prime contractor” for the work as defined in the *Workers’ Compensation Act*, R.S.B.C. 1996, c. 492 as amended and will ensure compliance with the *Workers Compensation Act* and Regulations in respect of the workplace. Without limiting its responsibilities under the legislation, the Contractor will coordinate the activities of employers, workers and other persons at the workplace relating to occupational health and safety. The Contractor shall have a safety program acceptable to the Workers’ Compensation Board, shall provide first aid services, and shall ensure that all Workers’ Compensation Board safety rules and regulations are observed during the performance of this Agreement, not only by the Contractor, but by all sub-contractors, workers, material personnel and others engaged by the Contractor in the performance of this Agreement. The prime contractor shall appoint a qualified coordinator for the purpose of ensuring the coordination of health and safety activities for the workplace. Prior to commencement of Construction, the Contractor shall complete and file a “Construction Notice of Project” with the Workers’ Compensation Board and shall provide a copy of the same to the City confirming that the Contractor shall be the prime contractor responsible for coordination of safety and health under Part 3 of the *Workers’ Compensation Act* and Part 20 of the WCB Occupational Health and Safety Regulations. That person will be the person so identified in this Agreement, and the Contractor will advise the City immediately in writing if the name or contact number of the qualified coordinator changes.
- 18.5 The Contractor will ensure compliance with and conform to all health and safety laws, by-laws or regulations of the Province of British Columbia, including without limitation any regulations requiring installation or adoption of safety devices or appliances.
- 18.6 The Contractor shall fulfill all its duties, obligations, and responsibilities in such a manner that it ensures the safety of the public and in accordance with the safety regulations of the Workers’ Compensation Board and shall install signs and barriers as required to ensure the safety of the public and of its employees in the use of the City facilities.
- 18.7 The Contractor understands and undertakes to comply with all the WCB Occupational Health and Safety Regulations for hazardous materials and substances, and in particular with the "Workplace Hazardous Materials Information System (WHMIS)" Regulations. All "Material Safety Data Sheets (MSDS)" shall be shipped along with the Goods, materials, products and any future MSDS updates will be forwarded.

**Appendix 1 – Prime Contractor Designation – Letter of Understanding**  
**Appendix 2 – Contractor Health & Safety Expectation – Responsibility of Contractors**

**19. BUSINESS LICENSE**

- 19.1 The Contractor will obtain and maintain throughout the term of this Agreement a valid City of Surrey business license.

**20. GENERAL PROVISIONS FOR GOODS**

- 20.1 Documentation for shipments of Goods from outside Canada shall be provided by a Contractor by airmail and shall include all documents as required by law or customary practice. All packages shall be marked as follows:

“Upon arrival, please contact customs broker:  
Livingston International Inc.  
Telephone: 604-685-3555  
Fax: 604-605-8231  
Email: [cst19@livingstonintl.com](mailto:cst19@livingstonintl.com)”

- 20.2 If this Agreement pertains to the fabrication, assembly or other processing of the Goods, representatives of the City shall be permitted free access at all reasonable times for the purpose of inspection, testing or obtaining information as to the progress of the fabrication, assembly or processing.
- 20.3 The City may require that shop drawings be submitted by the Contractor for review prior to the delivery of the Goods. The City may require that a qualified registered professional engineer stamp and approve a shop drawing prior to submission. Any review of shop drawings by the City will not relieve the Contractor from its obligation to deliver Goods in full compliance with all requirements of this Agreement.

## **21. COMPLIANCE**

- 21.1 The Contractor will provide the Services in full compliance with all applicable laws, building codes and regulations.
- 21.2 The Contractor will, as a qualified and experienced practitioner, interpret applicable codes, laws and regulations applicable to the performance of the Services. If an authority having jurisdiction imposes an interpretation which the Contractor could not reasonably have verified or foreseen prior to entering into this Agreement, then the City will pay the additional costs, if any, of making alterations so as to conform to the required interpretation.

## **22. JURISDICTION OF COUNCIL AND NON-APPROPRIATION**

- 22.1 Nothing in this Agreement limits or abrogates, or will be deemed to limit or abrogate, the jurisdiction of the Council of the City in the exercise of its powers, rights or obligations under any public or private statute, regulation or by-law or other enactment.
- 22.2 The Contractor recognizes and agrees that the City cannot make financial commitments beyond the City's current fiscal year. The City will annually make bonafide requests for appropriation of sufficient funds to cover all payments covered by this Agreement. If City Council does not appropriate funds, or appropriates insufficient funds, the City will notify the Contractor of its intention to terminate or reduce the services so affected within 30 days after the non-appropriation becomes final. Such termination shall take effect 30 days from the date of notification, shall not constitute an event of default and shall relieve the City, its officers and employees, from any responsibility or liability for the payment of any further amounts under this Agreement.

## **23. WAIVER**

- 23.1 Any failure of the City at any time or from time to time to enforce or require the strict keeping or performance of any of the terms and conditions contained in this Agreement shall not constitute a waiver of the terms and conditions and shall not affect or impair the

terms or conditions in any way or the City's right at any time to avail itself of any remedies as the City may have for any breach of the terms and conditions.

## **24. APPLICABLE LAW**

24.1 This Agreement shall be governed by and construed in accordance with the laws of the Province of British Columbia. The City and the Contractor accept the jurisdiction of the courts of British Columbia and agree that any action under this Agreement shall be brought in such courts.

## **25. NOTICES**

25.1 Any notice, report or other document that either party may be required or may wish to give to the other must be in writing, unless otherwise expressly provided for, and will be deemed to be validly given to and received by the addressee:

- (a) by hand, on delivery;
- (b) by facsimile, on transmission; or
- (c) by mail, five calendar days after posting.

25.2 The addresses for delivery will be as shown in the Quotation. In addition, the City may give notice to the Contractor by email at the Contractor's email address as shown in the Quotation, which email will be deemed to be validly given and received by the Contractor on transmission. The Contractor may not give notice to the City by email.

## **26. MERGER AND SURVIVAL**

26.1 The representations, agreements, covenants and obligations set out in this Agreement shall survive the delivery of the Goods and performance of the Services and payment of the Fees and Disbursements.

## **27. ENTIRE AGREEMENT**

27.1 This Agreement, including the Schedules and any other documents expressly included by reference in this Agreement, contains the entire agreement of the parties regarding the provision of the Goods and Services, and no understandings or agreements, oral or otherwise, exist between the parties except as expressly set out in this Agreement. This Agreement supersedes and cancels all previous agreements between the parties relating to the Goods and Services.

27.2 In the event that the Contractor issues an invoice, packing slip, sales receipt, or any like document to the City, the City accepts the document on the express condition that any terms and conditions in it which constitute terms and conditions which are in addition to or which establish conflicting terms and conditions to those set out in this Agreement are expressly rejected by the City.

## **28. SIGNATURE**

28.1 This Agreement shall be signed by a person authorized to sign on behalf of the Contractor.

28.2 This Agreement may be executed in or one or more counterparts all of which when taken together will constitute one and the same Agreement, and one or more of the counterparts may be delivered by fax transmission or as a PDF file.

## 29. FUEL EMISSIONS DATA

29.1 As of January 1, 2013, the City requires contractors to report the quantity of fuel used to operate vehicles, equipment and machinery as part of the delivery of operating (non-capital) services defined as "Traditional Services" in the Carbon Neutral Workbook.v2 as part of the BC Climate Action Charter. Typical data to be submitted would include the following for each calendar year:

- Type of vehicle/vehicle class used to deliver the contracted services;
- Type of fuel consumed by each vehicle class; and
- Litres of fossil fuels consumed in relation to the service delivered under the contract.

29.2 Fuel consumption associated with the provision of these services must be provided to the City within thirty (30) days of the end of the calendar year or the termination of the contract, whichever is earlier. An excel-based Fuel Use Reporting template will be provided by the City. The most current version of the workbook is located on the Climate Action Toolkit website for your reference at <http://toolkit.bc.ca/carbon-neutral-government>.

## 30. NON ROAD DIESEL ENGINE EMISSION REGULATION

30.1 If you **own, operate, or hire** diesel powered equipment, Metro Vancouver's Non-Road Diesel Engine Emissions Regulation Bylaw No 1161, 2012 (the Bylaw) may impact your business. The Bylaw came into force on January 1, 2012 and requires owners or operators to register and label Tier 0 and Tier 1 non-road diesel engines that are 25 horsepower (19kW) or greater in order to operate within Metro Vancouver. Tier 0 engines must have **90 days** of registration purchased by **December 31, 2014** or the engine(s) will be **prohibited from ever operating** in Metro Vancouver. To be fully registered an owner/operator must:

- provide required information (machine/engine/company details),
- pay fees, and
- label machines with Metro Vancouver issued registration number.

30.2 Other important information:

- Non-road Tier 1 engines must be registered and pay fees to operate,
- Failure to comply with the Bylaw may result in fines up to \$200,000, and
- 80% of fees paid into the program can be recovered.

30.3 The City may, at its discretion, give preference to equipment that meets higher emission standards.

30.4 Contact Metro Vancouver staff at 604-451-6655, visit [www.metrovancouver.org/nonroaddiesel](http://www.metrovancouver.org/nonroaddiesel) or email [nonroaddiesel@metrovancouver.org](mailto:nonroaddiesel@metrovancouver.org) for more information about the Bylaw, the rebate program, and for assistance with the registration process.

**31. ENUREMENT**

31.1 This Agreement shall enure to the benefit of and be binding upon the respective successors and permitted assigns of the City and the Contractor.

**IN WITNESS WHEREOF** the parties hereto have executed this Agreement on the day and year first above written.

**CITY OF SURREY**

by its authorized signatory(ies):

\_\_\_\_\_  
(Signature of Authorized Signatory)

\_\_\_\_\_  
(Signature of Authorized Signatory)

\_\_\_\_\_  
(Print Name and Position of Authorized Signatory)

\_\_\_\_\_  
(Print Name and Position of Authorized Signatory)

**<<NAME OF CONTRACTOR>>**

**I/We have the authority to bind the Contractor.**

\_\_\_\_\_  
(Legal Name of Contractor)

\_\_\_\_\_  
(Signature of Authorized Signatory)

\_\_\_\_\_  
(Signature of Authorized Signatory)

\_\_\_\_\_  
(Print Name and Position of Authorized Signatory)

\_\_\_\_\_  
(Print Name and Position of Authorized Signatory)

**(APPENDICES 1 & 2 WILL BE INSERTED LATER WHEN AN AGREEMENT IS ASSEMBLED FOR EXECUTION INCLUDING INFORMATION FROM THE RFQ AND SUCCESSFUL QUOTATION.)**



## SCHEDULE A SPECIFICATIONS OF GOODS AND SCOPE OF SERVICES

### 1. GENERAL

The City of Surrey manages a City-wide Street Banner and Seasonal Lighting Program. The Contractor will be regularly engaged with providing banner and seasonal lighting installation/removal and maintenance services for the City.

City of Surrey has 4 kinds of street banners:

- (a) Public Art Street Banners: Put out by the Neighbourhood Team and Public Art
- (b) Town Centre Banners: Providing colour and identity to each town centre
- (c) Community Banners: Initiated by community groups, business improvement associations, non-profits etc.
- (d) City Promotion Banners: Highlighting special programs and events within the City

Our Current Street banner collection:

Browse through the photo gallery to view Surrey's current (2016) banner collection. - See more at: <http://www.surrey.ca/community/548.aspx>.

The City has seasonal lighting on street poles and trees in each of Surrey's six town centres, as well as in Holland Park and key gateway locations.

The City reserves the right upon consultation with the Contractor, to establish or change the days of Service, hours of Service, plans, or other methods of Services delivery.

The City will make all decisions to any question which may arise as to the quality or acceptability of work performed, as to the manner of performance and rate of progress of the work and all questions which arise as to the interpretation of the specifications.

All Services performed by the Contractor and their personnel are to be done to the satisfaction of the City.

### 2. SERVICES

#### 2.1 Banner Service

The City maintains banners on 876 poles (see attached pole inventory and map). Unless otherwise noted, banners are to be installed in pairs on each pole.

- (a) The Contractor will provide all labour, materials, equipment, transportation, supervision for installation, maintenance and removal services for its banner program. The City is seeking a **per pole cost quotation** based on a per pole visit (assuming multiple poles are serviced).
- (b) Many of the banner pairings will be installed / removed twice annually; therefore, contractors are to assume 1500 pole trips per year for installation/removal.
- (c) Periodic maintenance is also required where needed to replace damaged banners or to secure banners that have become detached. Banners Service may also be required for special events.

- (d) The Contractor is to be available at all reasonable times to report and confer with City staff with respect to banner Service. The Contractor will designate an individual to serve as the primary point of contact for the Service. Contractor, or designate must respond to City Service requests within two (2) business days. In the event of a problem or potential problem that could impact the quality or level of Service, the Contractor is to notify the City within one (1) business day.

## 2.2 Banner Hardware

Banner hardware (brackets and rods) is provided by the City. In most cases hardware is installed on each pole.

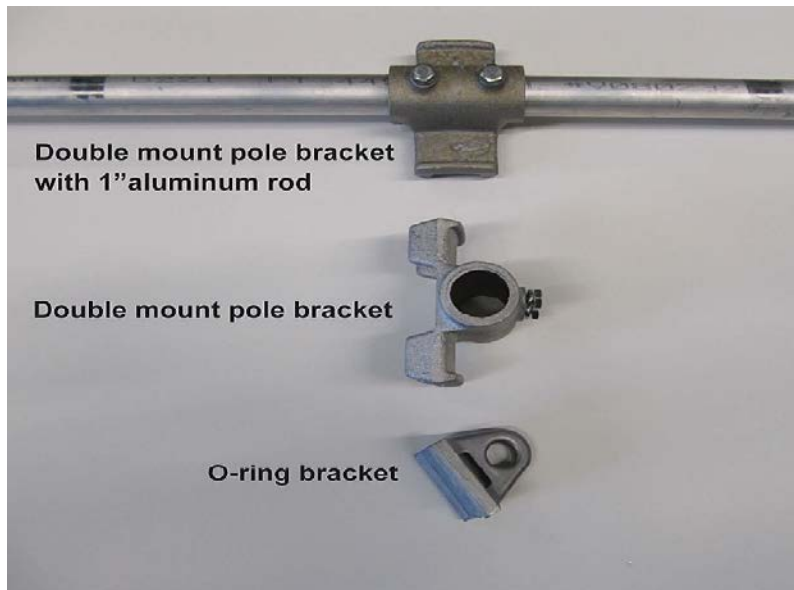

- (a) Where required, the Contractor will install or remove banner hardware. Brackets are secured to the poles using  $\frac{3}{4}$ " metal banding.
- (b) The Contractor will provide, where required,  $\frac{3}{4}$ " metal banding and commercial cable ties (zap straps) to secure hardware and banners to poles. When banners are not installed brackets are to remain installed on poles, while rods are to be removed and stored at facilities provided by the Contractors.

## 2.3 City Banner Format

The banners have two formats, based on pole height:

- (a) *Standard Format Banner – for poles 7.6m and above*

Standard City banners are 66cm x 183 cm (26" x 72"), with a tapered triangular bottom. The top of the banner is fitted with a 3.5" sleeve to slide over a 1" banner rod, while the bottom has a grommet to attach to an O-ring bracket. The banners are mounted to the pole with a single 1" thick aluminum rod (top mount) and an o-ring bracket (bottom). The rod is secured to the pole with a double mount pole bracket. Both the rod bracket and the O-ring bracket are secured to the pole with  $\frac{3}{4}$ " metal banding. Commercial cable ties

(zap straps) secure the banner to the hardware. 614 of the 769 poles receive standard format banners.

(b) *Large Rectangular Format Banner – for straight poles 7.6 m and above*

Large Rectangular format banners are 77cm x 208 cm (30.5" x 82"), rectangular, with a 3.5" top and bottom sleeves to slide over 1" aluminum rod on both the top and bottom. Both top and bottom 1" rods are secured to the pole with double mount pole bracket which are attached to the pole with 3/4" metal banding. Commercial cable ties (zap straps) secure the banner to the hardware.

**Refer to Schedule A-3 Banner Specifications & Dimensions**

2.4 Seasonal Lighting

The Services include:

- (a) all seasonal lighting pole feature work, street and park tree lighting installation and removal, receptacle work, repair, inventory and maintenance of features and light strings and other work not part of banner contract.
- (b) storage and organization of seasonal lighting materials in an offsite warehouse arranged by the Contractor. Inventory reporting when equipment is removed and stored as well as reporting on/off dates for lighting is also *required*. Any new lights or lighting features will be shipped directly to the contractor.

**Refer to Schedule A-4 Pole Features and Schedule A-5 Seasonal Light Trees Features**

**3. GENERAL DUTIES AND OBLIGATIONS (CONTRACTOR)**

3.1 Safety & Traffic Control

- (a) The Contractor is to abide by Section 3.0 (Short Duration) of the Ministry of Transportation and Highways Traffic Control Manual for Work on Roadways. The Contractor shall furnish and maintain cautionary signage, barricades, and/or traffic cones as required in advance of work sites adjacent to road edge or median edge.
- (b) The Contractor is to use a bucket truck for installation of banners. Work vehicles conducting Service must have the necessary safety equipment, as detailed in Section 3.0 (Short Duration) of the Ministry of Transportation and Highways Traffic Control Manual for Work on Roadways.
- (c) The Contractor will provide personnel with protection against safety and health hazards by furnishing them with all the protective equipment needed. Areas that require the wearing of protective clothing or where protective equipment is necessary must be identified to personnel during training and by the use of adequate signs.

### 3.2 Pole Damage & Hazard Reporting

In the event of pole damage or hazards relating to Service, such as rusting or damaged poles, close proximity of electrical lines, loose wiring or tree or foliage impediments, the Contractor will notify the City of the damage or hazard within one (1) business day. The Contractor shall not install banners on any damaged poles or hazardous locations.

### 3.3 Storage

The Contractor is to provide secured facilities for the storage of banners and banner hardware when not on City poles. The Contractor will maintain a numbered inventory of all banners and hardware in storage. Any seasonal lighting should be stored and organized at an off site location.

### 3.4 Hardware Preparation

If needed, banner hardware (rods and brackets) will be shipped directly to the Contractor. In some cases the 1" aluminum rods may require trimming to the necessary banner length. The contractor shall, in such cases, have the facilities or contacts to arrange the necessary work. In such cases the work will be invoiced on a separate and supplementary basis.

### 3.5 Permit

The Contractor will obtain a City of Surrey 'Road Right of Way' and 'Traffic Obstruction Permit' prior to commencing work. Any necessary permitting will be coordinated following the selection of a quote. Do not include any permit fees within quote.

## **4. CONTRACTOR'S VEHICLES AND EQUIPMENT**

4.1 The Contractor's vehicles and equipment used in the performance of the Services shall be properly equipped to deliver the Services. All vehicles and equipment shall be kept clean, in good mechanical condition, painted to present a neat appearance, show evidence of annual safety inspections and display proper registration and license information. All of the Contractor's vehicles and equipment shall be equipped with approved back-up alarms, multiple lite revolving / strobe lights, or other necessary warning systems, which shall be maintained and in proper operating condition at all times. In the event of a breakdown, the Contractor shall arrange for reserve equipment, with always the intent to maintain the schedule frequency.

4.2 Vehicles used in the performance of the Services shall be identified on both sides with the full company name, telephone number and ID/ unit number. This must be fully legible and displayed in a professional manner. The Contractor may also be required to display magnetic signs as supplied by the City, identifying the Contractor as a City Contractor. This shall not replace the company identification on the sides of vehicles and equipment.

4.3 Driving speed through City parks will be at a maximum of 10 km/ hour, and the Contractor's vehicles must keep to paved pathways and roads throughout the park to avoid damage to City parkland and park assets. Amber lights on each vehicle must be used during the course of business in City parks.

- 4.4 A list of in carrying out the Service, or any portion thereof, the convenience of the public must always be considered and provided for by the Contractor, who must not obstruct any street, thoroughfare or sidewalk longer than necessary. All pedestrian walkways must be maintained in a safe condition at all times. Any discontinuities likely to prove hazardous to the public and / or pedestrians must be removed, barricaded or clearly and safely marked.

## **5. COMMUNICATION**

- 6.1 The Contractor shall be available at all reasonable times to report and confer with City staff with respect to the Services. Communication shall be available via email and telephone. Phone conversations must be followed up with written communication.
- 6.2 The Contractor shall be available to attend planning meetings hosted by The City in advance of each event.
- 6.3 The Contractor will designate an individual to serve as the primary point of contact for the Agreement. The Contractor shall not change the primary point of contact without written authorization from the City. Contractor will also designate a backup point of contact in the event the primary is not available.
- 6.4 In the event of a problem or potential problem that may impact the quality or quantity of work, services, or the level of performance under this Agreement, the Contractor shall notify the City **immediately** in writing and by telephone.

## **6. INCLEMENT WEATHER**

- 7.1 While the Services are to be continuous, the City reserves the right to suspend any or all work due to poor weather conditions. The City reserves the right to authorize the delayed work to be performed at a later date, or the City may deem it more appropriate to omit the delayed work and resume the normal schedule. The Contractor should not perform any suspended work without written authorization from the City.
- 7.2 While work is suspended due to inclement weather conditions, the Contractor should maintain readiness to resume work when conditions again become favorable enough to proceed.

## **7. HEALTH, SAFETY AND PROTECTION**

- 8.1 The Contractor shall be responsible for initiating, maintaining, and supervising all safety precautions and programs in connection with the Services. The Contractor shall take every precaution to instruct personnel about and otherwise safeguard them against any possible injuries as well as other potential hazards within the parks.
- 8.2 Accident Reports: The Contractor shall comply with all WCB regulations and other regulatory agency requirements for record keeping and reporting of all accidents resulting in death, trauma, or occupational illness. The Contractor shall provide a verbal report to the City staff within one hour of occurrence and a written follow-up report to the City staff within 24 hours of the occurrence.

8.3 The Contractor shall conform to all applicable Federal, Provincial and local laws, and to the requirements of this Agreement. In performing Services under this Agreement the Contractor must:

- (a) Take all reasonable steps and precautions to prevent accidents and to preserve the health and safety of Contractor's personnel performing or in any way coming into contact with the performance of this Agreement;
- (c) Take such additional precautions as the City staff may reasonable require for health, safety and environmental protection; and,
- (d) Any violation of these health, safety and environmental rules and regulations, unless promptly corrected as directed by the City staff shall be grounds for termination of this Agreement in accordance with the Default Clause of this Agreement.

**-END OF PAGE-**

## SCHEDULE A-1 BANNER POLE LIST OF LOCATIONS

Canada 150 Banner Plan 2017													
Location	POLE DETAILS				BANNER FORMAT	CC	SEMI	CLVD	NWTN	GF	FTW Blue	Canada 150 - art	Gateway
	Number	Height	Style	On-Road Location									
<b>WHALLEY/CITY CENTRE</b>													
<i>Surrey City Centre</i>													
King George: 94A-96 Ave	8	9.1m	Davit/Cobra	Both sides	Paired, standard	8							
King George: 96-98 Ave	15	9.1m	Davit/Cobra	West side only	Paired, standard	22							
King George: 98Ave - 100Ave	32	9.1m	Davit/Cobra	Both sides	Paired, standard	32							
King George: 100Ave - 102Ave	16	9.1m	Davit/Cobra	Both sides	Paired, standard	16							
King George: 102Ave - 104 Ave	16	9.1m	Davit/Cobra	Both sides	Paired, standard	16							
King George: 104Ave - 105A Ave	12	9.1m	Davit/Cobra	Both sides	Paired, standard	12							
King George: 105A Ave- 108Ave	18	9.1m	Davit/Cobra	Both sides	Paired, standard	18							
King George: 108Ave - Bentley	6	9.1m	Davit/Cobra	Both sides	Paired, standard	6							
King George: @ Gateway Dr.	3	9.1m	Davit/Cobra	West side only	Paired, standard	3							
King George: 128th St. - 132nd St.	17	9.1m	Davit/Cobra	North side only	Paired, standard								17
University Dr (UD): 100-102A	14	10.7m	City Centre Tall	Both sides	Paired, rectangle							14	
University Dr (UD): 102A-104	18	10.7m	City Centre Tall	Both sides	Paired, rectangle							18	
University Dr: 104-105A	12	10.7m	City Centre Tall	Both sides	Paired, rectangle							12	
University Dr: 105A-108	16	10.7m	City Centre Tall	West side only	Paired, rectangle							16	
100Ave (Old Yale): KG - UD	18	9.1m	Davit/Cobra	Both sides	Paired, standard							18	
Parkway: 103 Ave-104Ave	3	10.7m	City Centre Tall	East side	Paired, Rectangle	3							
102AAve: UD - Parkway	3	10.7m	City Centre Tall	North side only	Paired, standard	3							
104Ave: UD to Parkway	8	10.7m	City Centre Tall	Both sides	Paired, Rectangle	8							
107A Ave: UD to Parkway	4	10.7m	City Centre Tall	Both sides	Paired, standard	4							
Bus Loop Parking Lot	4	9.1m	dbl Davit/Cobra	In parking lot	Paired, standard	4							
<i>South Whalley</i>													
King George (KG): 84Ave - 88Ave	36	9.1m	Davit/Cobra	Both sides	Paired, standard							36	
Nordel Way: east of 120th to train tracks	4	9.1m	Davit/Cobra	Median	Paired, standard								4
120 St: 2 poles n of 96, 10 poles s	12	9.1m	Davit/Cobra	East side	Paired, standard								12
REMOVE 88th Ave: KGB - Laudner Dr	6	7.6m	Square Davit	North Side of 88th	Paired, standard								
<b>TOTAL CITY CENTRE:</b>	<b>295</b>												
<b>SEMIAHMOO</b>													
152nd St: 16Ave to 18Ave	22	7.6m	Square Davit	Both sides	Paired, standard	22							
152nd St: 18Ave to 19Ave	10	7.6m	Square Davit	Both sides	Paired, standard	10							
152nd St: 19Ave to 20Ave	10	7.6m	Square Davit	Both sides	Paired, standard	10							
Martin Dr: 152nd St. - 16 Ave	17	9.1m	Davit/Cobra	Both sides	Paired, standard	17							
148th between 18A and 20 Ave	12	9.1m	Davit/Cobra	Both sides	Paired, standard							12	
148th between 20 Ave and 22 Ave	8	9.1m	Davit/Cobra	East side	Paired, standard							8	
<i>Ocean Park</i>													
16 Ave: 128 St to 129A Street	11	7.6m	Square Davit	Both sides	Paired, standard								
128 St: 15A Ave to 17Ave	10	7.6m	Square Davit	Both sides	Paired, standard								
<b>TOTAL SOUTH SURREY:</b>	<b>100</b>												
<b>NEWTON</b>													
64 Ave: east of 120th	8	9.1m	Davit/Cobra	Both sides	Paired, standard								8
120th St: 3 poles N & S of 64 Ave	6	9.1m	Davit/Cobra	East side only	Paired, standard								6
72nd St: 6 poles east of 120th	6	9.1m	Davit/Cobra	North side	Paired, standard								6
120th St: 6 poles N & S of 72 Ave	12	9.1m	Davit/Cobra	East side only	Paired, standard								12
80th: east of 120th	4	9.1m	Davit/Cobra	North side only	Paired, standard								4
REMOVE 128th St: 72Ave -74Ave	5	11m	Davit/Cobra	Median	Paired, standard								
REMOVE 128th St: 74Ave -76Ave	3	11m	Davit/Cobra	Median	Paired, standard								
REMOVE 128th St: 68Ave -72Ave	7	9.1m	Davit/Cobra	Both sides	Paired, standard								
REMOVE King George: 56Ave (Hwy	20	13.5m	Davit/DbL Cobra	Median	Paired, standard								

**Canada 150 Banner Plan 2017**

Location	POLE DETAILS				BANNER FORMAT	CC	SEMI	CLVD	NWTN	GF	FTW Blue	Canada 150 - art	Gateway
	Number	Height	Style	On-Road Location									
<b>Newton Town Centre</b>													
King George: 74Ave - 76Ave	18	9.1m	Davit/Cobra	Both sides	Paired, standard				18				
King George: 72Ave - 74Ave	19	9.1m	Davit/Cobra	Both sides	Paired, standard				19				
King George: 68Ave - 72Ave	33	9.1m	Davit/Cobra	Both sides	Paired, standard				33				
138th St.: 70Ave - 74Ave	24	9.1m	Davit/Cobra	Both sides	Paired, standard				24				
NEW 72nd King George -134 74 Ave: from 137Ath to 138 th	13	9.1m	Davit/Cobra	Plus 3 on s.	Paired, standard				13				
REMOVE 72Ave: King George to 138th St	6	7.6	Davit/Cobra	Both Sides	Paired, standard				6				
REMOVE 72Ave: King George to 138th St	7	7.6m	Speciality Davi	median	Paired, standard								
REMOVE 72Ave: King George to 138th St	32	6.5	Speciality Davi	Both sides	Paired, Short								
REMOVE 137th from 72nd to 74 Ave	17	6.5	Specialty Davi	Both Sides	paired, Short								
REMOVE 74 Ave: from KGB to 137Ath	12	6.5	Specialty Davi	Both Sides	paired, Short								
REMOVE 138th St: 74 Ave to KGB	38	9.1m	Davit/Cobra	Both sides	Paired, standard								
<b>TOTAL NEWTON TOWN CENTRE:</b>	<b>255</b>												
<b>GUILDFORD</b>													
REMOVE 104Ave: 148th St. - 150nd St	9	9.1m	Davit/Cobra	South side	Paired, standard								
104Ave: 150th St. - 152nd St.	10	9.1m	Davit/Cobra	Both sides	Paired, standard				10				
104Ave: 152nd St. - 153rd St.	10	9.1m	Davit/Cobra	Both sides	Paired, standard				10				
REMOVE 153 Ave: 104-105 Ave	10	9.1m	Davit/Cobra	Both sides	Paired, standard								
105Ave: West of 152nd St (Rec Centre	4	9.1m	Davit/Cobra	Both sides	Paired, standard				4				
152nd St: 104Ave - 105Ave	8	9.1m	Davit/Cobra	Both sides	Paired, standard				8				
152nd St: 101Ave - 104Ave	30	9.1m	Davit/Cobra	Both sides	Paired, standard				30				
152nd St: Ferguson to Hwy 1	14	9.1m	Davit/Cobra	Both sides	Paired, standard								14
160th St: 106 Ave to HWY 1	4	9.1m	Davit/Cobra	East Side	Paired, standard								4
<b>TOTAL GUILDFORD:</b>	<b>99</b>												
<b>CLOVERDALE</b>													
Fraser Hwy: 194th St. - 196th St.	8	9.1m	Davit/Cobra	Both sides	Paired, standard								8
Fraser Hwy: west of 188th	6	9.1m	Davit/Cobra	South side	Paired, standard								6
Hwy 10: West of 192nd	8	9.1m	Davit/Cobra	North side	Paired, standard								8
<b>Cloverdale Town Centre</b>													
176th St: Hwy 10 - 59Ave	66	7.6m	Speciality	Both sides	Single, standard			66					
176A St: Hwy 10 - 60Ave	14	7.6m	Speciality	Both sides	Paired, standard			14					
NEW 56 A Ave:176A-177B	4	9.1	Specialty	South Side	Single, Standard			4					
Cloverdale By-Pass: 56 Ave - 64 Ave	56	11m	Davit/Cobra	Both sides	Paired, double rod			56					
Hwy 10: 176-180 St.	22	9.1m	Davit/Cobra	Both sides	Paired, double rod			22					
<b>TOTAL CLOVERDALE:</b>	<b>184</b>												
<b>FLEETWOOD</b>													
Fraser hwy 7 poles west of 159th	7	11m	Davit/Cobra	South side only	Paired, standard								7
Fraser Hwy: Venture Way - 160th St.	4	11m	Davit/Cobra	South side only	Paired, standard								4
Fraser Hwy: 160th - 84 Ave	6	11m	Davit/Cobra	South side only	Paired, standard								6
Fraser Hwy: 84Ave - 164th St.	10	11m	Davit/Cobra	South side only	Paired, standard								10
Venture Way: Fraser HWY to 85 Ave	5	9.1m	Davit/Cobra	Both sides	Paired, standard								5
160th St: 83 Ave - 84Ave	4	9.1m	Special Davit	West side only	Paired, standard								4
160th St: 84Ave - 86 Ave	7	9.1m	Davit/Cobra	West side only	Paired, standard								7
84Ave: 159th St. - 160th St.	14	9.1m	Special Davit	Both sides	Paired, standard								14
84th west of Fraser Highway	2	9.1 m	Davit/Cobra	Both sides	Paired, standard								2
159th N of Fraser Highway	5	9.1 m	Davit/Cobra	Both sides	Paired, standard								5
164 St. between Fraser H and 84th	4	9.1 m	Davit/Cobra	West side only	Paired, standard								4
<b>TOTAL FLEETWOOD:</b>	<b>68</b>												
						<b>CC</b>	<b>SEMI</b>	<b>CLVD</b>	<b>NWTN</b>	<b>GF</b>	<b>FTW</b>	<b>Canada 150 Art</b>	<b>Gateway</b>
Total available poles	<b>1001</b>				Subtotals:	155	59	92	113	62	68	134	109
					Singles			70					
					# bars to be replaced								
					To Order Extras Pairs:	5	3	5	5	3	3	3	5
					to order singles			75					
					To order Total Pairs	160	62	97	118	65	71	137	114
					Total banner pairs	824							





**SCHEDULE A-3  
BANNER SPECIFICATIONS & DIMENSIONS**



**City Banner Program  
Banner Specifications & Dimensions**

**FORMAT A: Standard Tapered: 26"x72"**

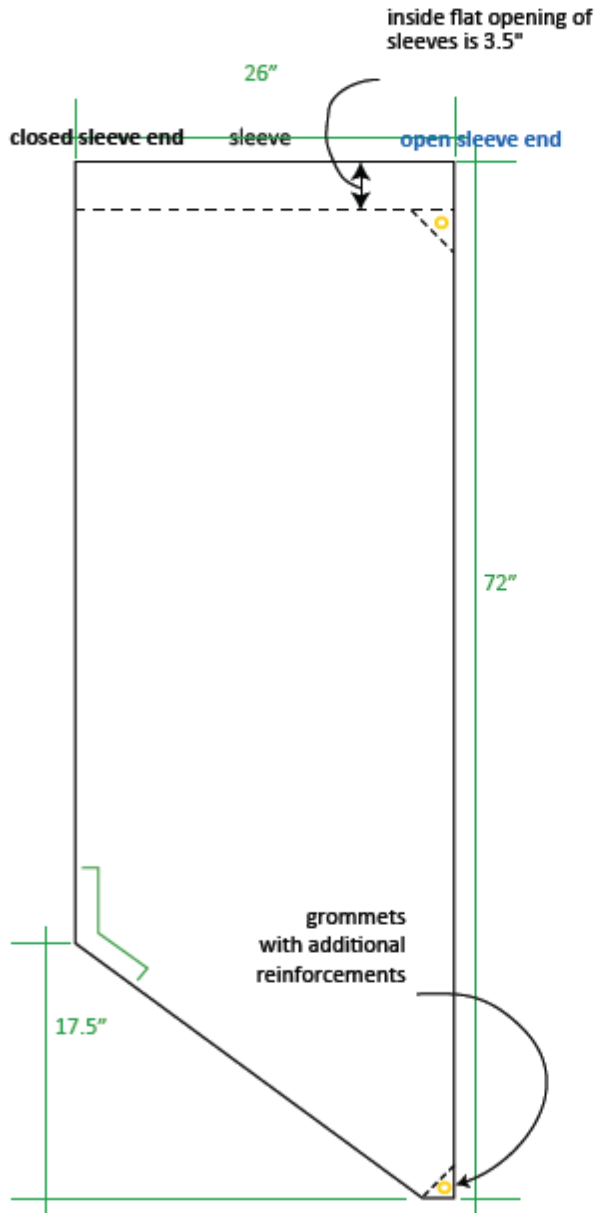

Paired banner should horizontally reflect

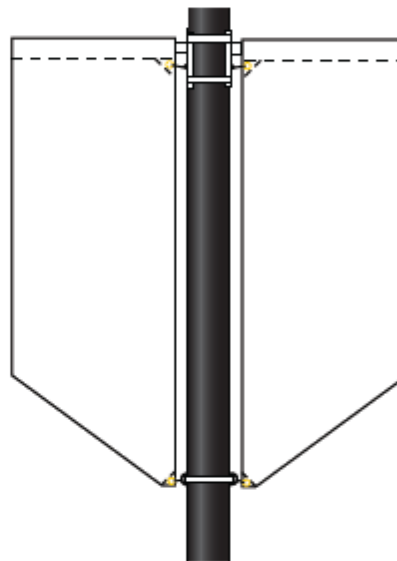

**SPECIFICATIONS**

**SUBSTRATE:**

recyclable or recycled material only

**SEWING:**

**Sleeves Specs:**

Open end sleeve, size depending on banner size.

Grommets/Gussets: 2 x 3/4" grommets and gussets per banner as shown, reinforced stitch.

**Edge Finish:**

Reinforced double stitch seam.

**FORMAT C: Large Rectangular: 30 1/2" x 82"**

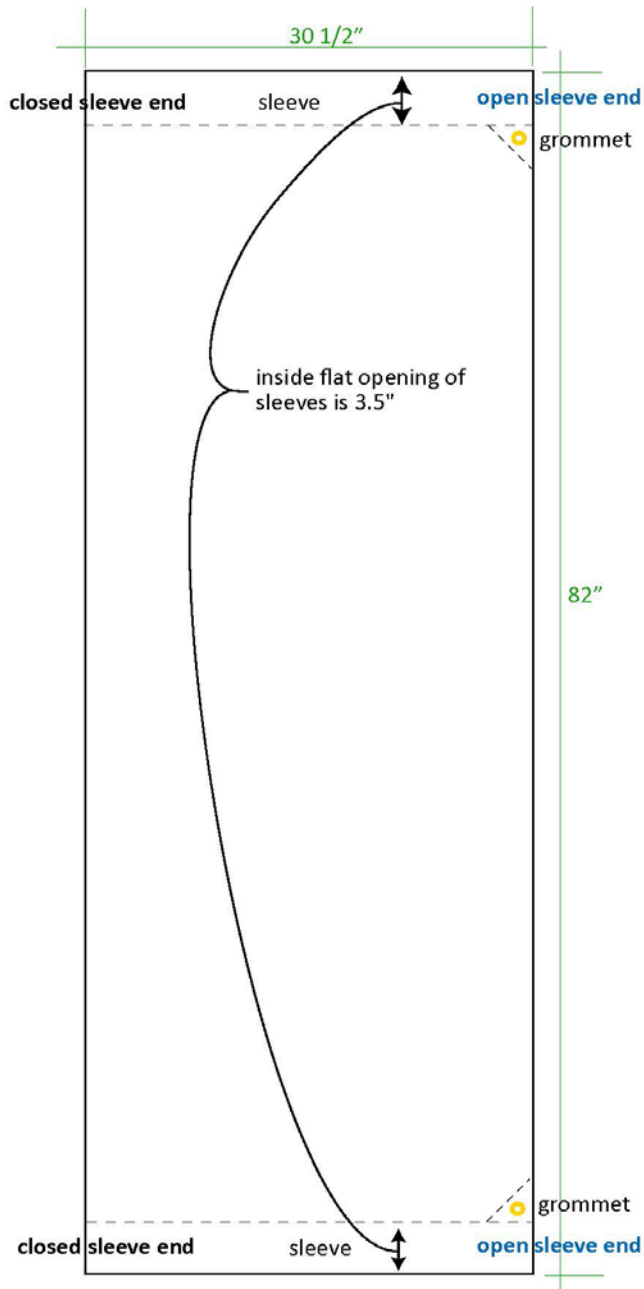

Paired banner should vertically reflect

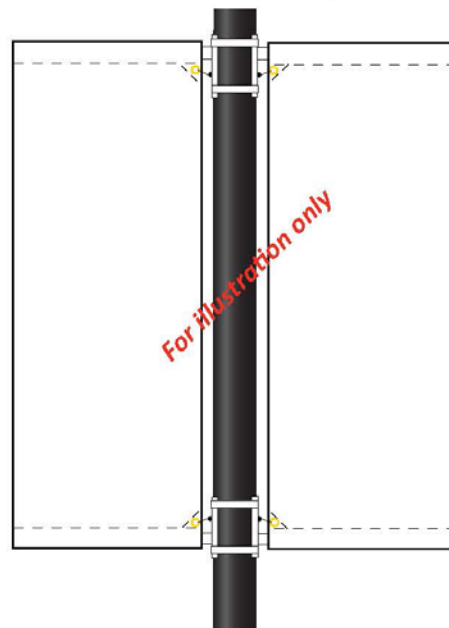

**SPECIFICATIONS**

**SUBSTRATE:**

recyclable or recycled material only  
(ie. first/second run polyester or  
substrates with post-consumer content)

**SEWING:**

**Sleeves Specs:**

Open end sleeve, size depending on banner size.  
Double stitch seam.

Grommets/Gussets: 2 x 3/4" grommets, with  
with gussets and reinforced stitching.

**Edge Finish:**

Reinforced double stitch seam.

**SCHEDULE A-4  
POLE FEATURES**

<b>Location &amp; Details</b>	<b>Number of features used</b>	<b>Date refurbished or purchased</b>
<b>Pole Features</b>		
<b>City Centre</b>		
Claris Feature (KGB) 98-108 -singles	73	
Snowflakes doubles (City Parkway, 102)	34	
Mistral (University Dr, 104, City Parkway, 102)	67	
Holland Park (lantern features)	58	new bulbs 2015
Holland Park bows	55	108 new bows
Chuck Bailey Spheres	23	refurbish 2016
<b>Newton</b>		
Newton (Large) (KGB 72-76th)	45	2013
Newton (Large) 128th (79th-82nd)	9	2013
Newton (Small) (72nd KGB-138th)	32	2013
Newton (Overhead)	7	2013
<b>Cloverdale</b>		
Cloverdale (Overhead)	2 (double features)	replace in 2017?
Cloverdale (Wreaths)	66	replace in 2017?
(176A) Snowflakes	14	
<b>Guildford</b>		
Shooting Star (Guildford)	52	Confirm final numbers
<b>Fleetwood</b>		
Falling Stars (Fleetwood) (3 poles west of 159th to 84th and Fraser Hwy), 160th (3 poles north of Fraser Highway to 4 poles south)	20	replace in 2017?
<b>South Surrey</b>		
Ocean Park (Features) <b>Refurbish</b>	40	refurbish in 2016
Semiahmoo (Features) 16-19 ave	32	
<b>NEW PLEASE NOTE- Remove all town centre banners (even on poles where there are no pole lights)</b>		
<b>total</b>	<b>317</b>	

## SCHEDULE A-5 SEASONAL LIGHT TREES FEATURES

Seasonal Lights Trees 2016-2017					
Location & Details	Colour	Number of trees	Bulb type	Strand length	Condition
<b>Tree Lights</b>					
<b>City Centre</b>					
Holland Park Tree - confirming about this year					fair
Holland Park Poles - nomas	cool white				
KGB 4 medians between 100-108 (Mini lights)(30 trees) <b>Reduced due to median change</b>	cool white	22	mini		new
2 feature trees at KGB and 108	cool white	2		25'	fair
City Hall plaza- 9 trees on east side of plaza	cool white	9	5m mini lights	5m	new
City Hall plaza- 6 trees on west side of plaza	cool white	6	PLR 80	5m	new
City Hall 6 floor balcony	cool white	n/a		?	new
Library roof	cool white	n/a		?	new
University 103-104 (23 trees) mini lights X2 strings	cool white	15		25'	NEW
Bus loop/Plaza area 16 trees c7s	cool white	16		25'	fair
Bus loop parking lot- (mini lights?) X3 strands connector path	cool white	16		25'	NEW
Holland Park- entrance trees	cool white	8		65'	good
<b>Newton</b>					
Newton bus loop (19 treesX2) mini lights		19		65'	good
Newton RCMP office 20 of mini lights (2 feature trees) Is this enough?	Cool White	2		65'	good
Street trees- Newton 137th	Cool White	20		?	?
King George n/of Hwy 10 - remove from trees in middle of median	Blue/green changers	14		25'	fair
Newton Arena feature tree (3 trees as one)	Blue and Green	3		25'	good
<b>Cloverdale</b>					
Cloverdale (1 large xmas tree)	red and white	1		25'	good
Street trees (3 strands 25')	warm white	36		25'	new
Investigate power on roundabout in Clayton (188 St and 68 Ave)					
<b>Guildford</b>					
Guildford xmas Tree (4 trees) 152nd Ferguson Div	Blue and Green	4			Good
8 trees in Medians on 152nd and Lincoln opposite rec Centre (mini lights-canopy wrap)	Cool White	10	PLR 80 branch wrap	4.5m	good
<b>Guildford - Balls at Lincoln</b>					
<b>Fleetwood</b>					
SSLC (1 tree)	Red/White	1			good
Fleetwood Library (8 trees)	blue/green	8		25'	Good
Tree on sw corner of 160th and 84th by "Thomas Fleetwood sculpture"	cool white	1		65'	Good
Fleetwood Street trees- motifs	warm white	20		10 m	New
<b>South Surrey</b>					
South Surrey Rec. Centre (1 tree)c9's	Cool White	1		25'	Good
152nd from 16-18th Ave- 3 Medians to (3 strands mini lights) 21 trees	cool white	21	PLR 80 Branch wrap	4.5 m	good



## SCHEDULE B - QUOTATION

RFQ Title: **Street Banner and Seasonal Lighting Installation & Maintenance**

RFQ No: 1220-040-2017-035

### CONTRACTOR

Legal Name: \_\_\_\_\_

Contact Person and Title: \_\_\_\_\_

Business Address: \_\_\_\_\_

Business Telephone: \_\_\_\_\_

Business Fax: \_\_\_\_\_

Business E-Mail Address: \_\_\_\_\_

### CITY OF SURREY

City Representative: Richard D. Oppelt, Purchasing Manager

Address: Surrey City Hall  
Finance & Technology Department – Purchasing Section  
Reception Counter – 5<sup>th</sup> Floor West  
13450 - 104 Avenue, Surrey, B.C., Canada, V3T 1V8

E-mail for PDF Files: [purchasing@surrey.ca](mailto:purchasing@surrey.ca)

1. If this Quotation is accepted by the City, a contract will be created as described in:
  - (a) the Agreement;
  - (b) the RFQ; and
  - (c) other terms, if any, that are agreed to by the parties in writing.
  
2. Capitalized terms used and not defined in this Quotation will have the meanings given to them in the Agreement and RFQ. Except as specifically modified by this Quotation, all terms, conditions, representations, warranties and covenants as set out in the Agreement and RFQ will remain in full force and effect.

3. I/We have reviewed the RFQ Attachment 1 – Draft Agreement. If requested by the City, I/we would be prepared to enter into that Agreement, amended by the following departures (list, if any):

**Section**

**Requested Departure(s) / Alternative(s)**

---



---

4. The City requires that the successful Contractor have the following in place **before providing the Goods and Services**:
- (a) Workers' Compensation Board coverage in good standing and further, if an "Owner Operator" is involved, personal operator protection (P.O.P.) will be provided,  
Workers' Compensation Registration Number \_\_\_\_\_;
  - (b) Prime Contractor qualified coordinator is Name: \_\_\_\_\_  
and Contact Number: \_\_\_\_\_;
  - (c) Insurance coverage for the amounts required in the proposed Agreement as a minimum, naming the City as additional insured and generally in compliance with the City's sample insurance certificate form available on the City's Website [Standard Certificate of Insurance](#);
  - (d) City of Surrey or Intermunicipal Business License: Number \_\_\_\_\_;
  - (e) If the Contractor's Goods and Services are subject to GST, the Contractor's GST Number is \_\_\_\_\_; and
  - (f) If the Contractor is a company, the company name indicated above is registered with the Registrar of Companies in the Province of British Columbia, Canada, Incorporation Number \_\_\_\_\_.

As of the date of this Quotation, we advise that we have the ability to meet all of the above requirements **except as follows** (list, if any):

**Requested Departure(s) / Alternative(s)**

---



---

5. The Contractor acknowledges that the departures it has requested in Sections 3 and 4 of this Quotation will not form part of the Agreement unless and until the City agrees to them in writing by initialing or otherwise specifically consenting in writing to be bound by any of them.

**SECTION B-1**

**Changes and Additions to Specifications:**

6. In addition to the warranties provided in the Agreement, this Quotation includes the following warranties:

---

- 
- 
7. I/We have reviewed the RFQ Attachment 1, Schedule A – Specifications of Goods and Scope of Services, to Attachment 1. If requested by the City, I/we would be prepared to meet those requirements, amended by the following departures and additions (list, if any):

**Requested Departure(s) / Alternative(s) / Addition(s)**

---



---

**SECTION B-2**

**Fees and Payments**

8. The Contractor offers to supply to the City of Surrey the Goods and Services for the prices plus applicable taxes as follows:

**Payment Terms:**

A cash discount of \_\_\_\_% will be allowed if invoices are paid within \_\_\_\_ days, or the \_\_\_\_ day of the month following, or net 30 days, on a best effort basis.

	<b>Item Name</b>	<b>Unit Price</b>
1.	<b>Banner Service:</b> Per pole installation, removal or replacement of City Banners, as outlined in Schedule A.	\$_____/pole
2.	<b>Seasonal Lights:</b> Installation, removal or replacement, as outlined in Schedule A.	\$_____/hr
	Electrician or extra crew with bucket truck	\$_____/hr
	Labourer with bucket truck	\$_____/hr
	Labourer only (no truck)	\$_____/hr
	Labourer with pickup truck	\$_____/hr
	Flagger with buffer truck	\$_____/hr
	High reach truck with operator	\$_____/hr
	<b><u>Others</u></b>	
1.	Labour (with Bucket Truck)	\$_____/hr
2.	Labour (No Truck)	\$_____/hr



**SECTION B-3**

**Time Schedule:**

9. Contractors should provide an estimated schedule, with major item descriptions and times indicating a commitment to provide the Goods and perform the Services within the time specified (use the spaces provided and/or attach additional pages, if necessary).

MILESTONE DATES \_\_\_\_\_

ACTIVITY	SCHEDULE									
	1	2	3	4	5	6	7	8	9	10
<b>SAMPLE</b>										

**SECTION B-4**

**Key Personnel & Sub-Contractors:**

10. Contractors should provide information on the background and experience of all key personnel proposed to provide the Goods and Services (use the spaces provided and/or attach additional pages, if necessary):

**Key Personnel**

Name: \_\_\_\_\_  
 Experience: \_\_\_\_\_  
 Dates: \_\_\_\_\_  
 Project Name: \_\_\_\_\_  
 Responsibility: \_\_\_\_\_

11. Contractors should provide the following information on the background and experience of all sub-contractors and material suppliers proposed to undertake a portion of the Goods and Services (use the spaces provided and/or attach additional pages, if necessary):

<i>Description Of Goods &amp; Services</i>	<i>Sub-Contractors &amp; Material Suppliers Names</i>	<i>Years Of Working With Contractor</i>	<i>Telephone Number And Email</i>

**SECTION B-5**

**and References:**

12. **Experience:** Contractor's should provide information on their relevant experience and qualifications in delivering Goods and Services similar to those required by the Agreement (use the spaces provided and/or attach additional pages, if necessary):

---



---

13. Contractor's should provide information on their relevant references (name and telephone number). The City's preference is to have a minimum of three references. Previous clients of the Contractor may be contacted at the City's discretion (use the spaces provided and/or attach additional pages, if necessary):

---



---



---

14. Contractor should describe their sustainability initiatives relating to the environmental impacts. The environmental attributes (green) of their Goods and Services. Anticipated objectives (e.g. carbon neutral by 2015). Information pertaining to their environmental policies, programs and practices. Confirm that the Contractor complies with any applicable objective (use the spaces provided and/or attach additional pages, if necessary):

---



---

**Metro Vancouver's Non-Road Diesel Engine Emissions Regulation By-law:**

15. Contractors should confirm they are in compliance with By-law (if applicable):

Applicable as follows     Not applicable to this project

No.	Equipment Description	Engine Tier Designation	Engine Registration Number as Issued by Metro Vancouver
1		<input type="checkbox"/> Tier 0 or <input type="checkbox"/> Tier 1	
2		<input type="checkbox"/> Tier 0 or <input type="checkbox"/> Tier 1	
3		<input type="checkbox"/> Tier 0 or <input type="checkbox"/> Tier 1	
4		<input type="checkbox"/> Tier 0 or <input type="checkbox"/> Tier 1	
5		<input type="checkbox"/> Tier 0 or <input type="checkbox"/> Tier 1	

SAMPLE

16. I/We the undersigned duly authorized representatives of the Contractor, having received and carefully reviewed the RFQ and the Agreement, submit this Quotation in response to the RFQ.

**This Quotation** is offered by the Contractor this \_\_\_\_\_ day of \_\_\_\_\_, 201\_\_.

**CONTRACTOR**

**I/We have the authority to bind the Contractor**

\_\_\_\_\_  
(Legal Name of Contractor)

\_\_\_\_\_  
(Signature of Authorized Signatory)

\_\_\_\_\_  
(Signature of Authorized Signatory)

\_\_\_\_\_  
(Print Name and Position of Authorized Signatory)

\_\_\_\_\_  
(Print Name and Position of Authorized Signatory)

**This Quotation** is accepted by the City this \_\_\_\_\_ day of \_\_\_\_\_, 201\_\_.

**CITY OF SURREY**

\_\_\_\_\_  
(Signature of Authorized Signatory)

\_\_\_\_\_  
(Signature of Purchasing Representative)

\_\_\_\_\_  
(Print Name and Position of Authorized Signatory)

\_\_\_\_\_  
(Print Name of Purchasing Representative)

\_\_\_\_\_  
(Signature of Authorized Signatory)

\_\_\_\_\_  
(Print Name and Position of Authorized Signatory)