



PROCUREMENT SERVICES

CITY OF SURREY, SURREY CITY HALL
13450 – 104 Avenue, Surrey, B.C., V3T 1V8
Tel: 604-590-7274
E-mail: purchasing@surrey.ca

ADDENDUM No. 3

REQUEST FOR QUOTATION No.:	1220-040-2022-071
TITLE:	Installation Services, City Wide Wifi
ADDENDUM ISSUE DATE:	August 17, 2022
(REVISED) DATE:	PREFER TO RECEIVE SUBMISSION ON OR BEFORE AUGUST 23, 2022

INFORMATION FOR CONTRACTORS

Contractors are advised that Addendum No.3 to 1220-040-2022-071 is hereby issued by the City. This addendum shall form part of the contract documents and is to be read, interpreted and coordinated with all other parts. The following information is provided to answer questions raised by Contractors for the above-named project, to the extent referenced and shall become a part thereof. No consideration will be allowed for extras due to the Contractors or any sub-contractor not being familiar with this addendum. This Addendum No. 3 contains three (3) pages.

QUESTIONS AND ANSWERS:

Q1. I don't see all of the sites in the information provided in Addendum Two?

A1. Some of the smaller sites are grouped in with nearby sites. The AP Name is the most accurate. For example, Museum and Archives are with Cloverdale Campus; Guildford Aquatics are with Guildford Campus; Newton Seniors and Newton Arena are with Newton Campus.

Q2. Could you please provide drawing/pictures of the brackets?

A2.

AP-MNT-MP10-A (9/16") and AP-MNT-MP10-B (15/16")

- The two mounts are different sizes, but assemble and function the same.
- Used on 9/16" or 15/16th Suprafine or "Tee Systems"
- 3 pieces total
 - Two rails assemble around the Tee rail, held together with a small clip on the tail side
 - The AP mount attached with two screws to the AP, and then slides around the two Tee-rail assemblies.
 - Secure with the spring loaded pin and then tighten the retention screw to lock it in

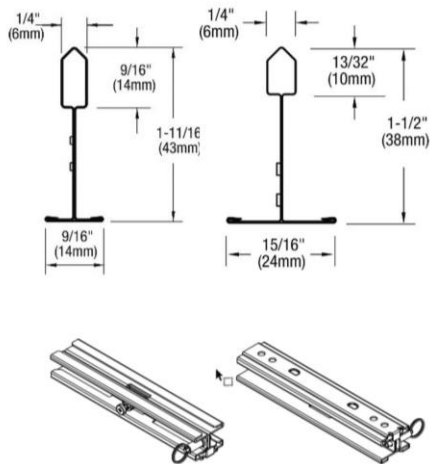

New AP-5xx Mount Location

Screw threads to secure AP mount



'Keyed' alignment knobs to ensure mount is properly installed.

All AP-5xx will ship with the Common Mount pre-attached (to minimize risk of customers damaging threads and to make new installs easier)



Pictured with the AP-555

AP-MNT-MP10-A (9/16") and AP-MNT-MP10-B (15/16")

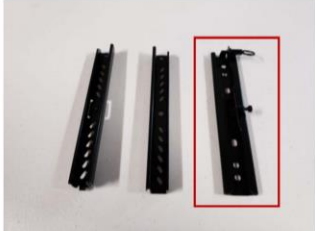

The common part of the mount is show inside the red box for illustrative purposes only. In production, this will be pre-installed on the AP, and the parts shipped will include the remaining parts required.

Pictured with the AP-555

All Addenda will become part of the Contract Documents.

- END OF ADDENDUM -