



REQUEST FOR PROPOSALS

Title: **Engineering Services for Inspection of Flood Box Construction**

Reference No.: 1220-030-2023-001

FOR PROFESSIONAL SERVICES (CONTRACTOR – GOODS AND SERVICES)

(General Services)

Issuance Date: December 19, 2022

TABLE OF CONTENTS

1. INTRODUCTION	3
1.1 Purpose	3
1.2 Definitions.....	3
2. INSTRUCTIONS TO PROPONENTS	4
2.1 Closing Time and Address for Proposal Delivery	4
2.2 Information Meeting	4
2.3 Late Proposals.....	4
2.4 Amendments to Proposals	4
2.5 Inquiries	5
2.6 Addenda	5
2.7 Examination of Contract Documents and Site.....	5
2.8 Opening of Proposals	5
2.9 Status Inquiries.....	6
3. PROPOSAL SUBMISSION FORM AND CONTENTS	6
3.1 Form of Proposal	6
3.2 Signature	6
4. EVALUATION AND SELECTION.....	6
4.1 Evaluation Team.....	6
4.2 Evaluation Criteria	7
4.3 Discrepancies in Proponent’s Financial Proposal	7
4.4 Litigation	8
4.5 Additional Information	8
4.6 Interviews	8
4.7 Multiple Preferred Proponents	8
4.8 Negotiation of Contract and Award	8
5. GENERAL CONDITIONS	9
5.1 No City Obligation.....	9
5.2 Proponent’s Expenses.....	9
5.3 No Contract	9
5.4 Conflict of Interest.....	10
5.5 Solicitation of Council Members, City Staff and City Contractors	10
5.6 Confidentiality	10
5.7 No Claims.....	10

SCHEDULE A – SPECIFICATIONS OF GOODS AND SCOPE OF SERVICES

SCHEDULE A-1 DRAWINGS

SCHEDULE A-2 MAPS

SCHEDULE B – DRAFT CONTRACT

SCHEDULE C – FORM OF PROPOSAL

REQUEST FOR PROPOSALS

1. INTRODUCTION

1.1 Purpose

Through this Request for Proposals (the “**RFP**”), the City of Surrey (the “**City**”) is seeking proposals from proponents (each a “**Proponent**”) to perform the services described in Schedule A – Specifications of Goods and Scope of Services (the “**Goods and Services**”). That schedule, with such modifications as may be agreed between the City and the successful Proponent(s), will be incorporated into the contract between the City and the successful Proponent(s).

1.2 Definitions

In this RFP the following definitions shall apply:

- (a) “**BC Bid Website**” means www.bcbid.gov.bc.ca;
- (b) “**City**” means the City of Surrey;
- (c) “**City Representative**” has the meaning set out in Section 2.5;
- (d) “**City Website**” means www.surrey.ca;
- (e) “**Closing Time**” has the meaning set out in Section 2.1;
- (f) “**Contract**” means a formal written contract between the City and a Preferred Proponent to undertake the Services, the preferred form of which is attached as Schedule B;
- (g) “**Evaluation Team**” means the team appointed by the City;
- (h) “**Goods**” has the meaning set out in Schedule A;
- (i) “**Information Meeting**” has the meaning set out in Section 2.2;
- (j) “**Preferred Proponent(s)**” means the Proponent(s) selected by the Evaluation Team to enter into negotiations for a Contract;
- (k) “**Proponent**” means an entity that submits a Proposal;
- (l) “**Proposal**” means a proposal submitted in response to this RFP;
- (m) “**RFP**” means this Request for Proposals;
- (n) “**Services**” has the meaning set out in Schedules A, A-2 and A-3;
- (o) “**Site**” means the place or places where the Goods are to be delivered and the Services are to be performed; and

(p) “**Statement of Departures**” means Schedule C-1 to the form of Proposal attached as Schedule C.

2. INSTRUCTIONS TO PROPONENTS

2.1 Closing Time and Address for Proposal Delivery

The Proponent should submit the Proposal **electronically** in a single pdf file which must be delivered by email at: purchasing@surrey.ca

on or before the following date and time

Time: 3:00 p.m., local time

Date: January 19, 2023

(the “Closing Time”).

Confirmation of receipt of email will be issued. Proposals that cannot be opened or viewed may be rejected. A Proponent bears all risk that the City’s receiving equipment functions properly so that the Proposal is received by the Closing Time.

Note: The maximum file size the City can receive is 10Mb. If sending large email attachments, Proponents should phone [604-590-7274] to confirm receipt.

2.2 Information Meeting

An information meeting may be hosted by the City Representative to discuss the City’s requirements under this RFP (the “**Information Meeting**”). While attendance is at the discretion of Proponents, Proponents who do not attend will be deemed to have attended the Information Meeting and to have received all of the information given at the Information Meeting. At the time of issuance of this RFP a meeting has not been scheduled.

2.3 Late Proposals

Proposals submitted after the Closing Time will not be accepted or considered. A Proponent bears all risk that the City’s receiving computer equipment functions properly so that the Proposal is received by the Closing Time.

2.4 Amendments to Proposals

Proposals may be revised by written amendment, delivered to the location set out in Section 2.1, at any time before the Closing Time but not after. An amendment should be signed by an authorized signatory of the Proponent in the same manner as provided by Section 3.2. E-mailed amendments are permitted, but such amendment should show only the change to the proposal price(s) and should not disclose the actual proposal price(s). A Proponent bears all risk that the City’s computer equipment functions properly so as to facilitate timely delivery of any amendment.

2.5 Inquiries

All inquiries related to this RFP should be directed in writing to the person named below (the “**City Representative**”). Information obtained from any person or source other than the City Representative may not be relied upon.

Name: Sunny Kaila, Manager Procurement Services

E-mail: purchasing@surrey.ca

Reference: 1220-030-2023-001

Inquiries should be made no later than 7 business days before Closing Time. The City reserves the right not to respond to inquiries made within 7 business days of the Closing Time. Inquiries and responses will be recorded and may be distributed to all Proponents at the discretion of the City.

Proponents finding discrepancies or omissions in the Contract or RFP, or having doubts as to the meaning or intent of any provision, should immediately notify the City Representative. If the City determines that an amendment is required to this RFP, the City Representative will issue an addendum in accordance with Section 2.6. No oral conversation will affect or modify the terms of this RFP or may be relied upon by any Proponent.

2.6 Addenda

If the City determines that an amendment is required to this RFP, the City Representative will issue a written addendum by posting it on the BC Bid website at www.bcbid.gov.bc.ca and the City website at www.surrey.ca (collectively, the “**Websites**”), and upon posting, any addenda will form part of this RFP. It is the responsibility of Proponents to check the Websites for addenda. The only way this RFP may be added to, or amended in any way, is by a formal written addendum. No other communication, whether written or oral, from any person will affect or modify the terms of this RFP or may be relied upon by any Proponent. By delivery of a Proposal the Proponent is deemed to have received, accepted and understood the entire RFP, including any and all addenda.

2.7 Examination of Contract Documents and Site

Proponents will be deemed to have carefully examined the RFP, including all attached Schedules, the Contract and the Site (as applicable) prior to preparing and submitting a Proposal with respect to any and all facts which may influence a Proposal.

2.8 Opening of Proposals

The City intends to open Proposals in private but reserves the right to open Proposals in public at its sole discretion.

2.9 Status Inquiries

All inquiries related to the status of this RFP, including whether or not a Contract has been awarded, should be directed to the City Website and not to the City Representative.

3. PROPOSAL SUBMISSION FORM AND CONTENTS

3.1 Form of Proposal

Proponents should complete the form of Proposal attached as Schedule C, including Schedules C-1 to C-5. Proponents are encouraged to respond to the items listed in Schedules C-1 to C-5 in the order listed. Proponents are encouraged to use the forms provided and attach additional pages as necessary.

3.2 Signature

The legal name of the person or firm submitting the Proposal should be inserted in Schedule C. The Proposal should be signed by a person authorized to sign on behalf of the Proponent and include the following:

- (a) If the Proponent is a corporation then the full name of the corporation should be included, together with the names of authorized signatories. The Proposal should be executed by all of the authorized signatories or by one or more of them provided that a copy of the corporate resolution authorizing those persons to execute the Proposal on behalf of the corporation is submitted;
- (b) If the Proponent is a partnership or joint venture then the name of the partnership or joint venture and the name of each partner or joint venturer should be included, and each partner or joint venturer should sign personally (or, if one or more person(s) have signing authority for the partnership or joint venture, the partnership or joint venture should provide evidence to the satisfaction of the City that the person(s) signing have signing authority for the partnership or joint venture). If a partner or joint venturer is a corporation then such corporation should sign as indicated in subsection (a) above; or
- (c) If the Proponent is an individual, including a sole proprietorship, the name of the individual should be included.

4. EVALUATION AND SELECTION

4.1 Evaluation Team

The evaluation of Proposals will be undertaken on behalf of the City by an evaluation team appointed by the City (the "**Evaluation Team**"), which may consist of one or more persons. The Evaluation Team may consult with others including City staff members, third party consultants and references, as the Evaluation Team may in its discretion decide is required. The Evaluation Team will give a written recommendation for the selection of a Preferred Proponent or Preferred Proponents to the City.

4.2 Evaluation Criteria

The Evaluation Team will compare and evaluate all Proposals to determine each Proponent's strength and ability to provide the Services in order to determine the Proposal, or Proposals, which are most advantageous to the City, using the following criteria:

- (a) Experience, Reputation and Resources – The Proponent's experience, reputation and resources as applicable to providing the Goods and the performance of the Services.
For this evaluation criterion The Evaluation Team will consider the Proponent's responses to items in Schedule C-2.
- (b) Technical – The Proponent's technical proposal for providing the Goods and performance of the Services as outlined in the Proponent's responses to items in Schedule C-3 and Schedule C-4.
- (c) Financial – The Proponent's financial proposal for providing the Goods and performance of the Services as described in the Proponent's response to Schedule C-5.
- (d) Statement of Departures - The Evaluation Team will consider the Proponent's response to Schedule C-1.

The Evaluation Team will not be limited to the criteria referred to above, and the Evaluation Team may consider other criteria that the Evaluation Team identifies as relevant during the evaluation process. The Evaluation Team may apply the evaluation criteria on a comparative basis, evaluating the Proposals by comparing one Proponent's Proposal to another Proponent's Proposal. All criteria considered will be applied evenly and fairly to all Proposals.

4.3 Discrepancies in Proponent's Financial Proposal

If there are any obvious discrepancies, errors or omissions in Schedule C-5 of a Proposal (Proponent's Financial Proposal), then the City shall be entitled to make obvious corrections, but only if, and to the extent, the corrections are apparent from the Proposal as submitted, and in particular:

- (a) if there is a discrepancy between a unit price and the extended total, then the unit prices shall be deemed to be correct, and corresponding corrections will be made to the extended totals;
- (b) if a unit price has been given but the corresponding extended total has been omitted, then the extended total will be calculated from the unit price and the estimated quantity; and
- (c) if an extended total has been given but the corresponding unit price has been omitted, then the unit price will be calculated from the extended total and the estimated quantity.

4.4 Litigation

In addition to any other provision of this RFP, the City may, in its absolute discretion, reject a Proposal if the Proponent, or any officer or director of the Proponent submitting the Proposal, is or has been engaged directly or indirectly in a legal action against the City, its elected or appointed officers, representatives or employees in relation to any matter, or if the City has initiated legal action against any officers or directors of the Proponent.

In determining whether or not to reject a Proposal under this Section, the City will consider whether the litigation is likely to affect the Proponent's ability to work with the City, its contractors and representatives and whether the City's experience with the Proponent indicates that there is a risk the City will incur increased staff and legal costs in the administration of the Contract if it is awarded to the Proponent.

4.5 Additional Information

The Evaluation Team may, at its discretion, request clarifications or additional information from a Proponent with respect to any Proposal, and the Evaluation Team may make such requests to only selected Proponents. The Evaluation Team may consider such clarifications or additional information in evaluating a Proposal.

4.6 Interviews

The Evaluation Team may, at its discretion, invite some or all of the Proponents to appear before the Evaluation Team to provide clarifications of their Proposals. In such event, the Evaluation Team will be entitled to consider the answers received in evaluating Proposals.

4.7 Multiple Preferred Proponents

The City reserves the right and discretion to divide up the Goods and Services, either by scope, geographic area, or other basis as the City may decide, and to select one or more Preferred Proponents to enter into discussions with the City for one or more Contracts to perform a portion or portions of the Goods and Services. If the City exercises its discretion to divide up the Goods and Services, the City will do so reasonably having regard for the RFP and the basis of Proposals.

In addition to any other provision of this RFP, Proposals may be evaluated on the basis of advantages and disadvantages to the City that might result or be achieved from the City dividing up the Goods and Services and entering into one or more Contracts with one or more Proponents.

4.8 Negotiation of Contract and Award

If the City selects a Preferred Proponent or Preferred Proponents, then it may:

- (a) enter into a Contract with the Preferred Proponent(s); or
- (b) enter into discussions with the Preferred Proponent(s) to attempt to finalize the terms of the Contract(s) including financial terms, and such discussions may include:

- (1) clarification of any outstanding issues arising from the Preferred Proponent's Proposal;
 - (2) negotiation of amendments to the departures to the draft Contract, if any, proposed by the Preferred Proponent as set in Schedule C-1 to the Preferred Proponent's Proposal; and
 - (3) negotiation of amendments to the Preferred Proponent's price(s) as set out in Schedule C-5 to the Preferred Proponent's Proposal and/or Goods and scope of Services if:
 - (A) the Preferred Proponent's financial Proposal exceeds the City's approved budget, or
 - (B) the City reasonably concludes the Preferred Proponent's financial proposal includes a price(s) that is unbalanced, or
 - (C) a knowledgeable third party would judge that the Preferred Proponent's price(s) materially exceed a fair market price(s) for services similar to the Goods and Services offered by the Preferred Proponent as described in the Preferred Proponent's Proposal; or
- (c) if at any time the City reasonably forms the opinion that a mutually acceptable agreement is not likely to be reached within a reasonable time, give the Preferred Proponent(s) written notice to terminate discussions, in which event the City may then either open discussions with another Proponent or terminate this RFP and retain or obtain the Goods and Services in some other manner.

5. GENERAL CONDITIONS

5.1 No City Obligation

This RFP is not a tender and does not commit the City in any way to select a Preferred Proponent, or to proceed to negotiations for a Contract, or to award any Contract, and the City reserves the right to at any time, and for any reason, reject all Proposals, and to terminate this RFP process without further explanation. The City is under no obligation to consider any Proposal, including the Proposal with the lowest price, or to select as the Preferred Proponent the Proponent that submits the Proposals with the lowest price.

5.2 Proponent's Expenses

Proponents are solely responsible for their own expenses in preparing, and submitting Proposals, and for any meetings, negotiations or discussions with the City or its representatives and consultants, relating to or arising from this RFP. The City and its representatives, agents, consultants and advisors will not be liable to any Proponent for any claims, whether for costs, expenses, losses or damages, or loss of anticipated profits, or for any other matter whatsoever, incurred by the Proponent in preparing and submitting a Proposal, or participating in negotiations for a Contract, or other activity related to or arising out of this RFP.

5.3 No Contract

By submitting a Proposal and participating in the process as outlined in this RFP, Proponents expressly agree that no contract of any kind is formed under, or arises from this RFP, prior to the signing of a formal written Contract.

5.4 Conflict of Interest

A Proponent shall disclose in its Proposal any actual or potential conflicts of interest and existing business relationships it may have with the City, its elected or appointed officials or employees. The City may rely on such disclosure.

5.5 Solicitation of Council Members, City Staff and City Consultants

Proponents and their agents will not contact any member of the City Council, City staff or City consultants with respect to this RFP, other than the City Representative named in section 2.5, at any time prior to the award of a contract or the cancellation of this RFP and which could be viewed as one Proponent attempting to seek an unfair advantage over other Proponents.

5.6 Confidentiality

All submissions become the property of the City and will not be returned to the Proponent. All submissions will be held in confidence by the City unless otherwise required by law. Proponents should be aware the City is a “public body” defined by and subject to the *Freedom of Information and Protection of Privacy Act* of British Columbia.

5.7 No Claims

Each Proponent, by submitting a Proposal, irrevocably:

- (a) agrees that it will not bring any claim, demand, action, cause of action, suit or proceeding, whether arising in contract, tort (including negligence) or otherwise (a “**Claim**”) against the City or any of its employees, directors, officers, advisors or representatives, or any one of them, for any costs, damages or other compensation for any matter relating directly or indirectly to this RFP (including in the event that the City rejects or disqualifies or for any other reason fails to accept a Proposal, accepts a non-compliant Proposal or otherwise breaches, or fundamentally breaches, the terms of this RFP or any duties arising from this RFP; and
- (b) waives any Claim against the City and its employees, directors, officers, advisors or representatives, or any one of them, for any compensation of whatsoever nature or kind, including for loss of anticipated profits, loss of opportunity, indirect, incidental or consequential damages or losses if no contract is entered into for the Services between the Proponent and the City for any reason whatsoever, including in the event that the City rejects or disqualifies or for any other reason fails to accept a Proposal, accepts a non-compliant Proposal or otherwise breaches, or fundamentally breaches, the terms of this RFP or any duties arising from this RFP.

[END OF PAGE]

**SCHEDULE A
SPECIFICATIONS OF GOODS AND SCOPE OF SERVICE**

PROJECT TITLE: ENGINEERING SERVICES FOR INSPECTION OF FLOOD BOX CONSTRUCTION

1. INTRODUCTION

The City of Surrey (the “City”) is seeking to retain the services of a professional contractor (the “Contractor”) to perform services for flood box construction monitoring, inspection and materials testing at various locations in the Surrey Lowlands.

The Contractor will provide the following services in accordance with the information provided within this Schedule A.

- Overall project management; and
- Resident field services.

2. PROJECT DESCRIPTION

2.1 Project Background

With the dissolution of the Surrey Dyking District, the City assumed their operation and maintenance responsibilities as of January 1, 2013. Part of these responsibilities are dyke and floodbox inspections. Throughout 2013, the flood boxes were inspected, and the condition of these assets was documented.

With this condition assessment completed, the City worked with a design consultant to establish a typical / standard design and construction program. This Project represents the replacement of the flood box inventory identified from flood box inspections.

2.2 Major Design Requirement

The key objectives of the assignment are below:

- (a) Construction monitoring for up to 5 flood box locations: 2 abandonments and 3 installs.
- (b) Material testing in conformance with Flood box install typical C1.00, C1.01 and C1.02.

	River	Address	ID	Type of Work	Pipe Diameter (mm)
1	Serpentine	8352-176 Street	US-15542-R	Install	900
2	Serpentine	7337- 176 Street	MS-12942-L	Install	900
3	Serpentine	4610-160 Street	LN-5727-R	Install	900
4	Serpentine	16280 64 Avenue	MS-9889-L	abandonment	750
5	Serpentine	16156 59 Avenue	MS-8282-L	abandonment	450

3. PROJECT MANAGEMENT AND GENERAL INSTRUCTIONS

3.1 Project Management

- (a) Schedule bi-weekly progress review meetings with the City and prepare and distribute meeting minutes. It is recommended that virtual meetings be utilized to minimize travel time and costs.
- (b) Prepare and submit monthly invoices including progress status reports identifying previously invoiced, current invoice, total to date and projected amounts, versus budget on a task by task or project area basis. The Contractor shall not exceed budget nor proceed with any scope change without prior written approval from the City.
- (c) For design packages with multiple projects, provide a summary sheet that shows the cost distribution of the invoice amount into each project. This is required for tracking the costs incurred for each project as part of the asset accounting requirements for the Public Sector Accounting Board (PSAB).
- (d) Coordinate with all required City departments, as required.
- (e) Conduct site visits to ascertain features and constraints that may impact the design.
- (f) Communicate with adjacent property owners regarding the intent, scope and expected construction timing of the project.
- (g) Apply good engineering practices/principles/standards when preparing designs and establishing estimates. Prepare designs in accordance with the City's [Design Criteria Manual](#).
- (h) Provide the City with all documents (survey, CAD files, model files, reports etc.) prepared for the project without copyright restrictions.

3.2 Property Impacts

- (a) Identify property impacts and liaise with the City's Realty Services Division and Engineering Operations Department in assessing the most economic and practical alternative in dealing with the encroachment or damage to land and properties adjacent to the proposed works.
- (b) Identify projects having significant impacts to private property or involving an increase in restriction to property access or business.

3.3 Outside Agency Coordination

- (a) Contact all relevant utility/government agencies to identify and resolve all current and future conflicts with respect to work under the project.
- (b) Prepare and submit the application for the *Dike Maintenance Act* approval and the Professional Engineer's letter of commitment.
- (c) Obtain cost estimates and schedules for the relocations of the utilities. The estimated cost of relocations shall be included in the total estimated cost of the Project as submitted to the City.
- (d) Arrange for and secure all necessary approvals (E.g. Hydro, Telus, Shaw, Fortis, MoTI, MoE, CPR, CNR, etc.).

3.4 Construction Services

- (a) Review and approve shop drawings. A copy should be provided to the City.
- (b) Assign to the site of the work a competent person or persons as the Contractor's representative and provide the following resident field services:
 - (1) Determine if the contractor is carrying out the work in compliance with

- the Contract;
- (2) Take field measurements, observe delivery quantity/weight records and force account records to ascertain the quantity of work executed for the purpose of payment under the contract;
 - (3) Record all details of construction for the preparation and submission of "As-Constructed" drawings;
 - (4) Oversee resolution of conflicts during construction;
 - (5) Ensure traffic control signs are in place at all times during construction, and all traffic signs are replaced after construction. Drive detour routes on a daily basis;
 - (6) Witness all tests required to ensure construction meets specifications and provide copies of all test and results to the City;
 - (7) Ensure erosion and sediment control measures are in place;
 - (8) If ESC Bylaw requirements are triggered, conduct weekly erosion and sediment control monitoring, including after every significant rainfall event with reporting to the Project Supervisor;
 - (9) Provide an electronic copy of the weekly construction inspection reports; and
 - (10) Perform a final inspection and prepare a Certificate of Substantial Performance complete with deficiency list and holdbacks estimates.
- (c) Review all invoices submitted by the contractor and prepare Monthly Progress Certificates.
 - (d) Provide required site instructions (SI).
 - (e) Prepare, issue and review contemplated change orders (CCO). Upon acceptance by the City, issue a change order (CO) to the contractor. Note, that the contractor does not have authority to approve a CO without prior acceptance by the City, notwithstanding that the City's project supervisor is available upon short notice to provide verbal approval of small change orders.
 - (f) Advise on and assist with the negotiation with claims by and against the contractors to the extent called for in the contract documents.
 - (g) Arrange frequent construction progress meetings with the contractor, sub-trades and the City, and prepare and distribute meeting minutes.
 - (h) Manage sub-consultants and quality assurance (QA) testing agencies. For purposes of this RFP, the Contractor's Proposal must include an allowance for QA testing.
 - (i) Provide the City with dated photographs of all areas of the work that affect private property prior to commencement and at the conclusion of the work and at critical times when new underground facilities are exposed.
 - (j) Complete post substantial performance certificate(s) on the Site no later than three (3) day from issuance, take photographs and provide letter with photographs of posted certificate to the City.

3.5 Post Construction Services

- (a) In the case of a flood box installation not following the City of Surrey standard design drawing for flood box replacement, prepare sealed ss-Constructed drawings and provide them to the Project Supervisor within 30 days of Substantial Performance. The Contractor shall be fully responsible for the adequacy and accuracy of the information in respect of the work constructed and other affected installations. "As-Constructed" drawings should include offsets

from property line, rim and invert elevations of all sewers and headwalls, size and locations of all connections and I.C. invert elevations, and any newly located utilities that were not originally shown.

- (b) Coordinating and undertaking the end of the one-year maintenance inspection with the contractor and appropriate representatives of the City.
- (c) Process lien and deficiency holdback release payment requests.

4. ESTIMATED TIME SCHEDULE

The successful Contractor team shall be fully committed to the project team members and to the project schedule. The anticipated timelines of the major activities under this assignment is as listed below:

Review of Proposals by Evaluation Team	January 31, 2023
Appointment of Contractor	March 1, 2023
Construction	May 1, 2023

NOTE: The Contractor should evaluate the estimated schedule above and recommend a revised schedule if this proposed schedule is not practical. The Contractor will indicate measures and recommendations to accelerate the schedule if possible.

[END OF PAGE]

**SCHEDULE A-1
DRAWINGS**

LOW LAND FLOOD BOX DESIGN

Description	Sheet #	Drawing #	Date
Flood Box Installation	1 of 3	C1.00	Dec. 20, 2019
Flood Box Installation	2 of 3	C1.01	Dec. 20, 2019
Flood Box Installation	3 of 3	C1.02	Dec. 20, 2019

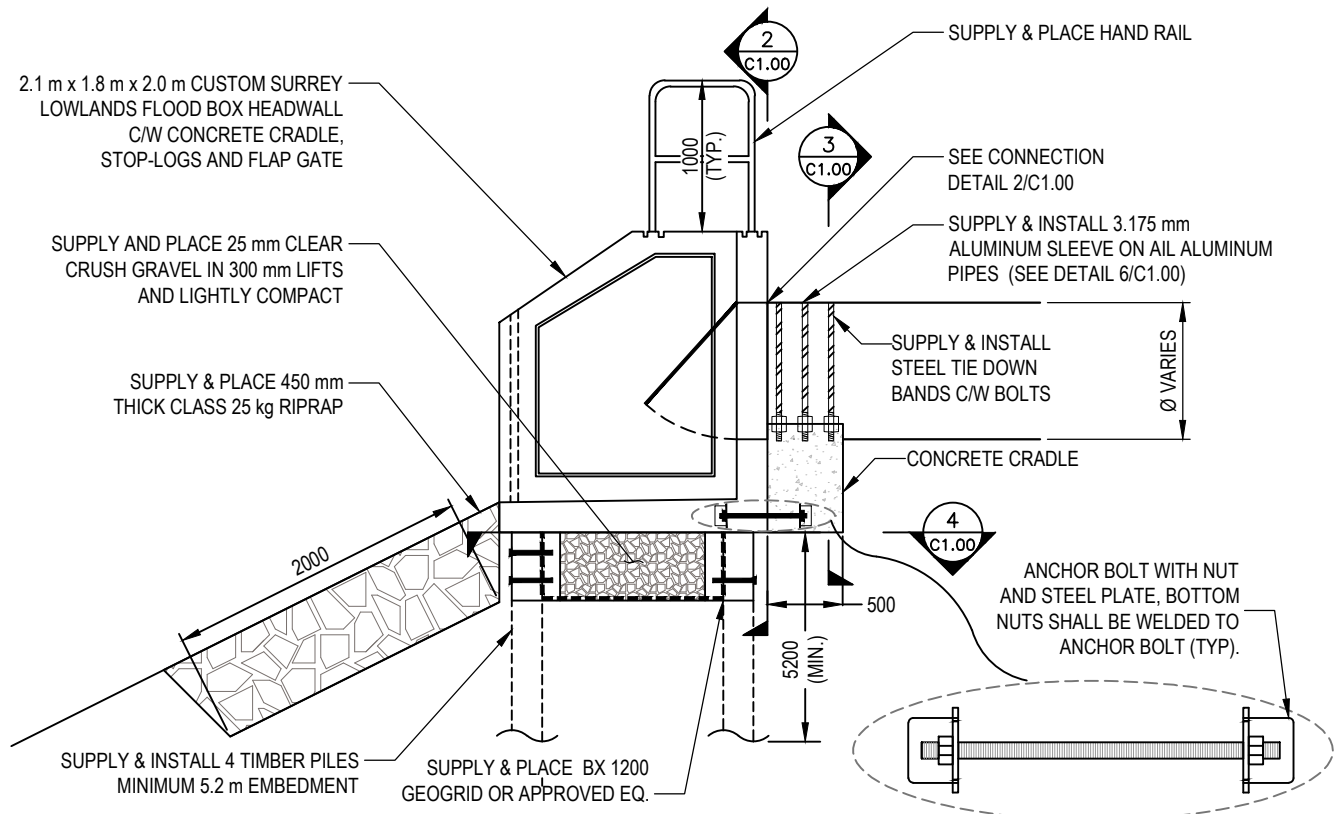

1 HEADWALL FOUNDATION DETAIL
C1.00 N.T.S

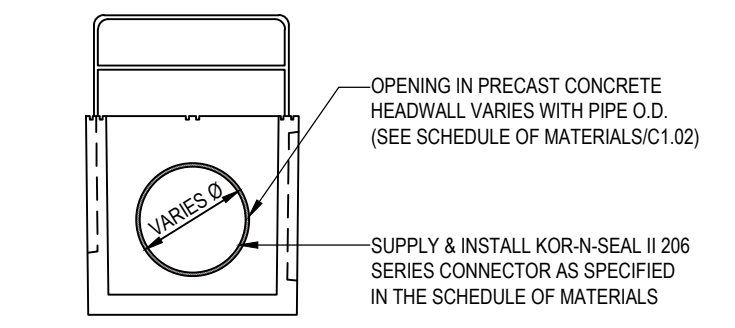

2 PIPE CONNECTION DETAIL
C1.00 N.T.S

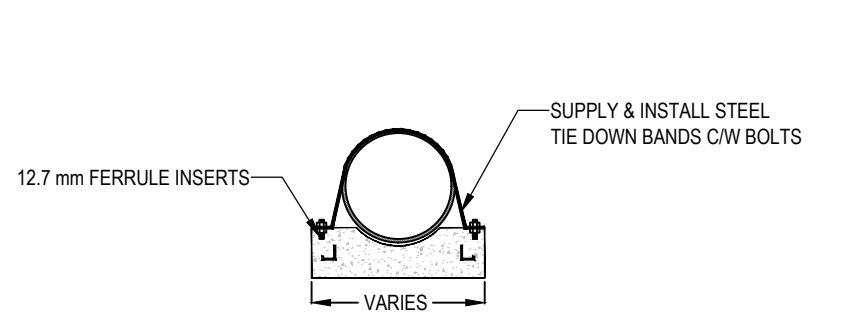

3 CONCRETE CRADLE TIE DOWN DETAIL
C1.00 N.T.S

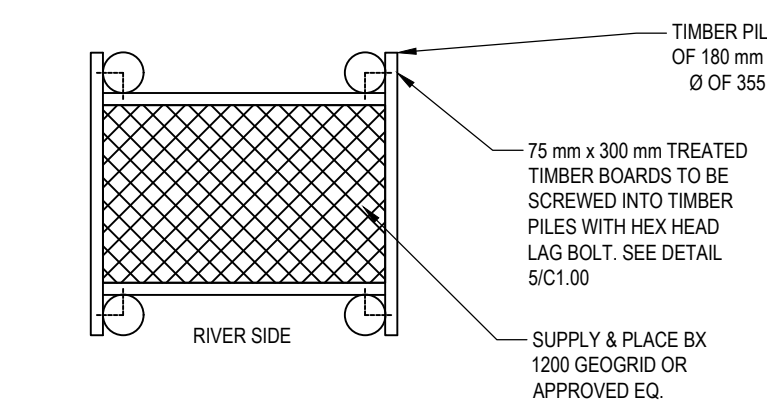

4 TIMBER BOARD INSTALLATION DETAIL
C1.00 N.T.S

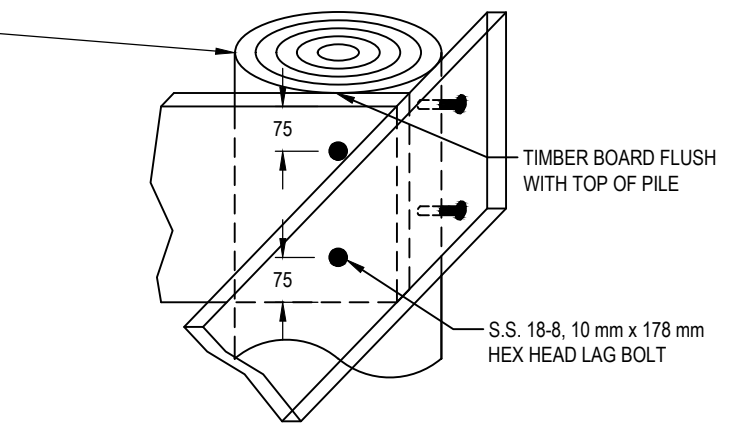

5 TIMBER BOARD/PILE CONNECTION DETAIL
C1.00 N.T.S

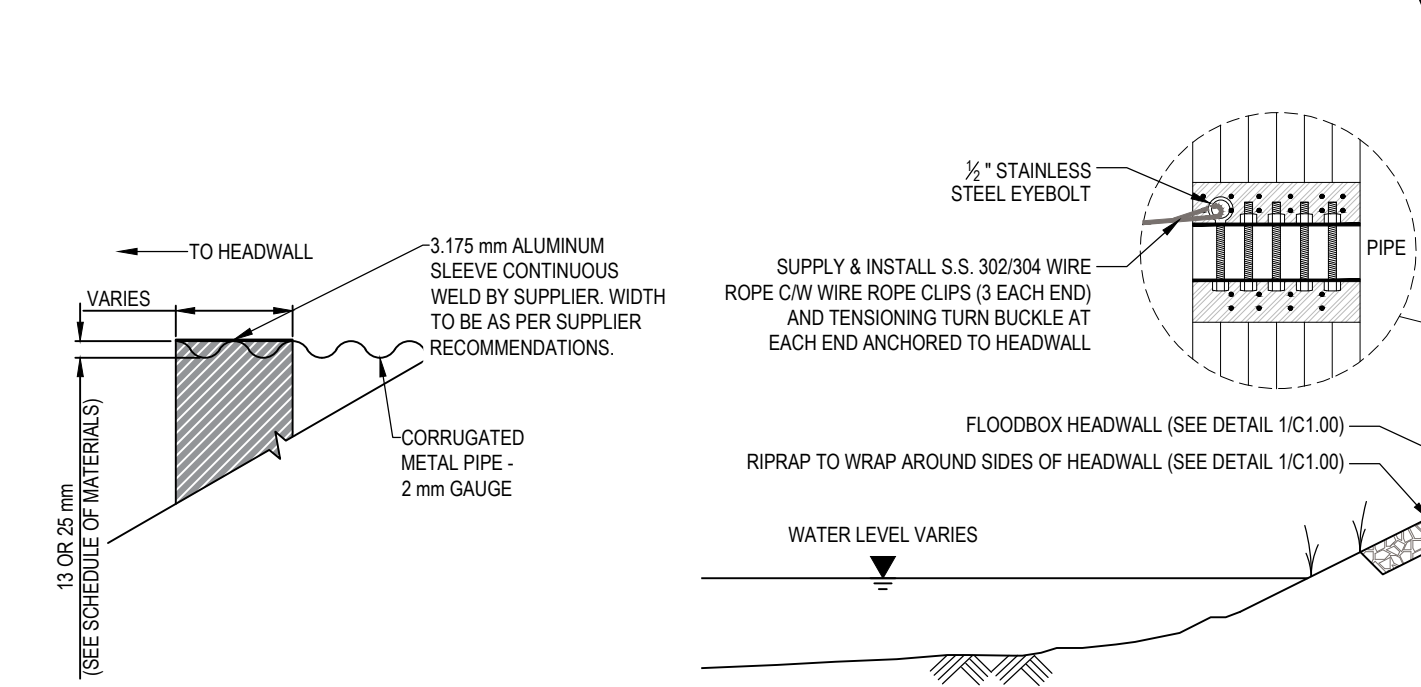

6 ALUMINUM SLEEVE BY SUPPLIER
C1.00 N.T.S

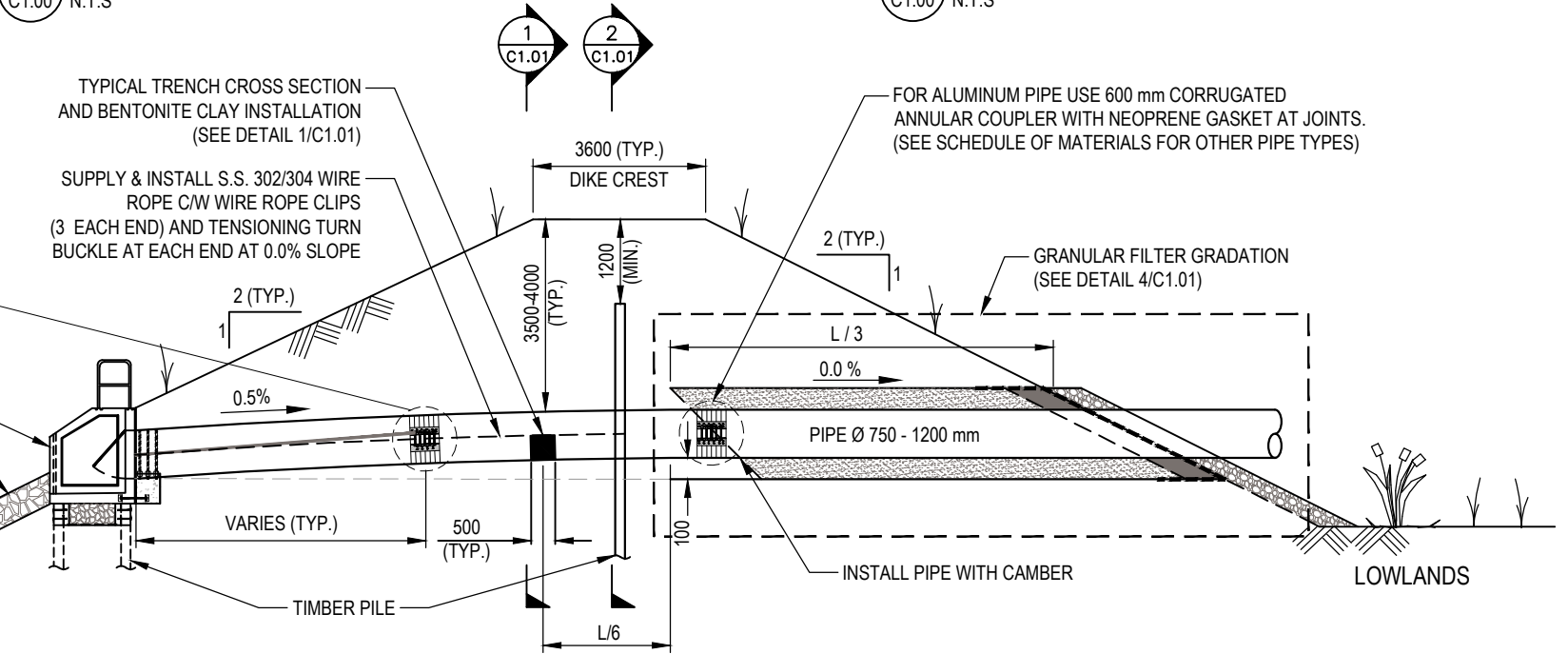

7 PROFILE VIEW
C1.00 N.T.S

NOTES:
1. ALL DIMENSIONS ARE IN MILLIMETERS UNLESS NOTED OTHERWISE.

NUM	DATE	DWN	CKD	APR	DESCRIPTION	NUM	DATE	APR	DESCRIPTION
A	12/20/2019	MJK	JW	DM	ISSUED FOR REVIEW				
REVISIONS									
DRAWING STATUS									



the future lives here.



SURREY LOWLANDS FLOOD BOXES
SURREY, B.C.

FLOOD BOX INSTALLATION

PROJECT No. V13203062-02
OFFICE VANC
DES DM
CKD JW
REV A

DATE: December 20, 2019
SHEET No. 1 of 3
DWN MJK
APP DM
STATUS IFR

C1.00

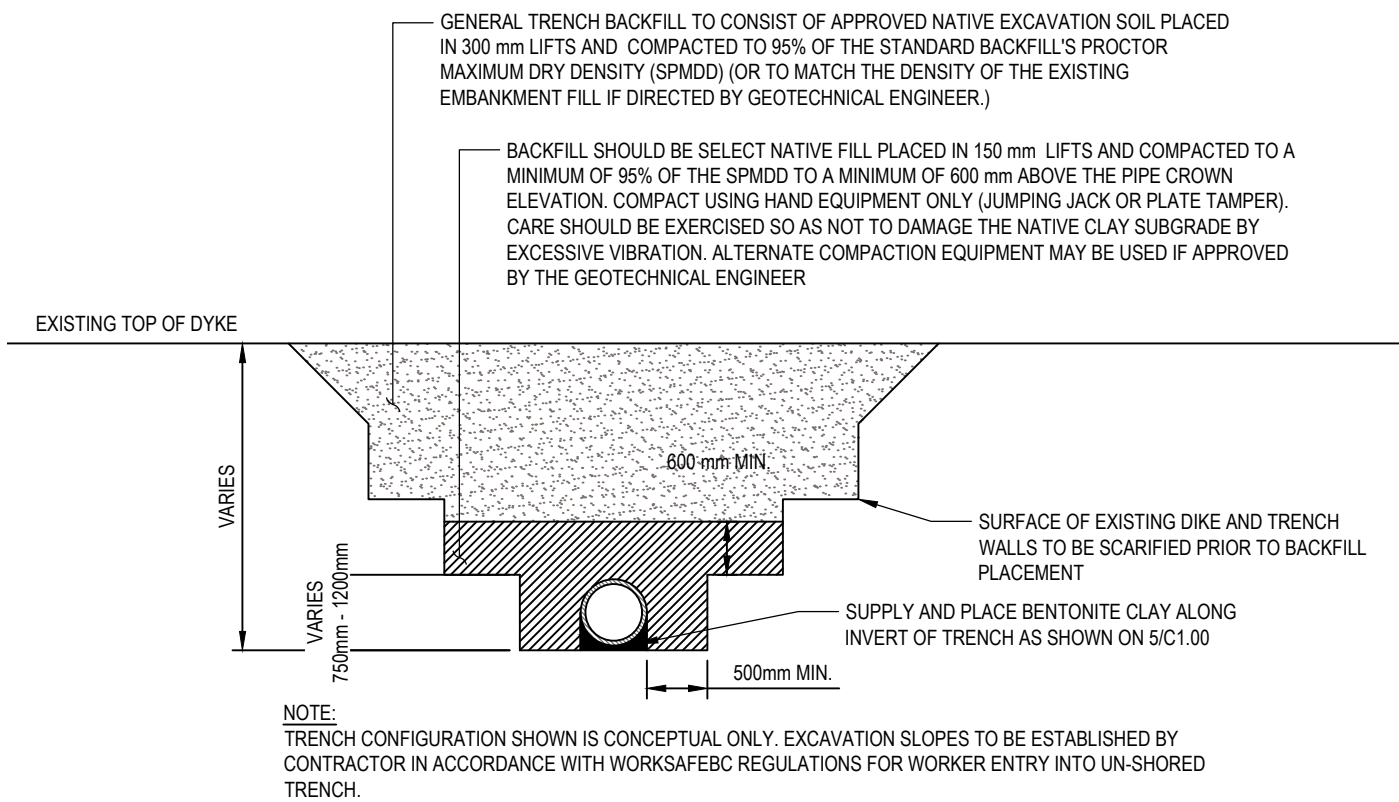

1 TYPICAL TRENCH DETAIL WITH BENTONITE INSTALLATION
C1.01 N.T.S.

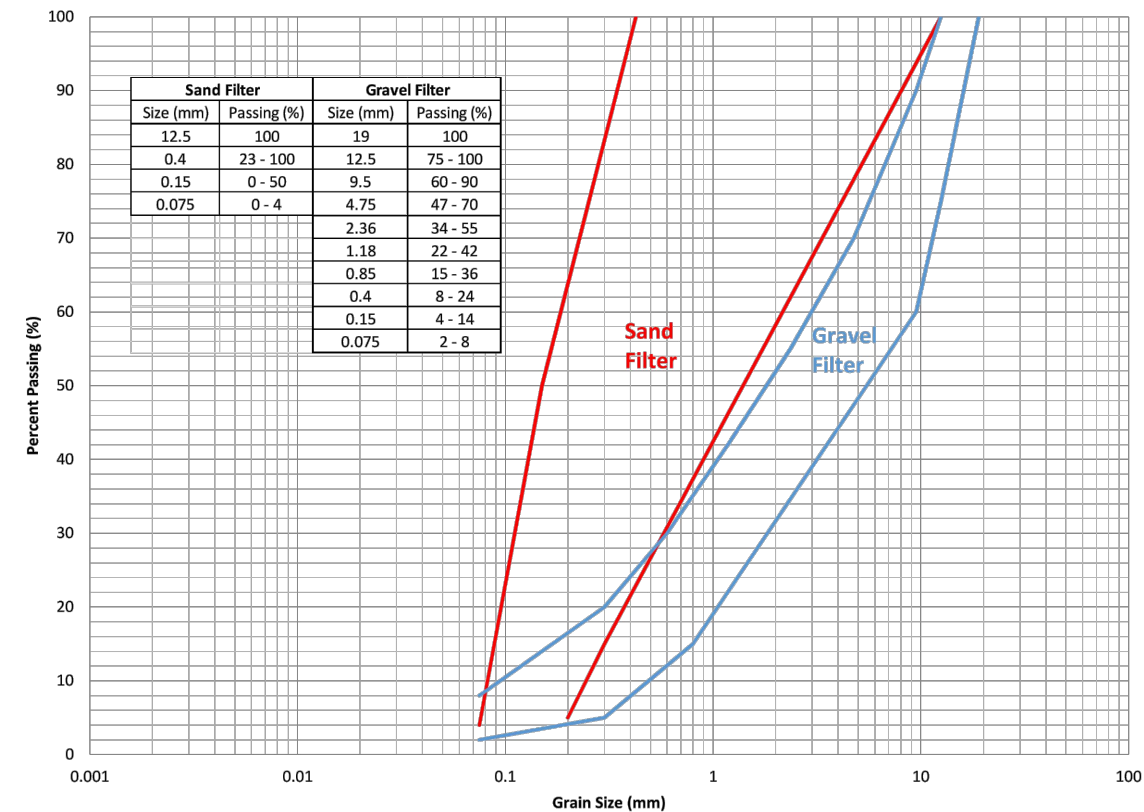

2 GRANULAR FILTER GRADATION
C1.01 N.T.S.

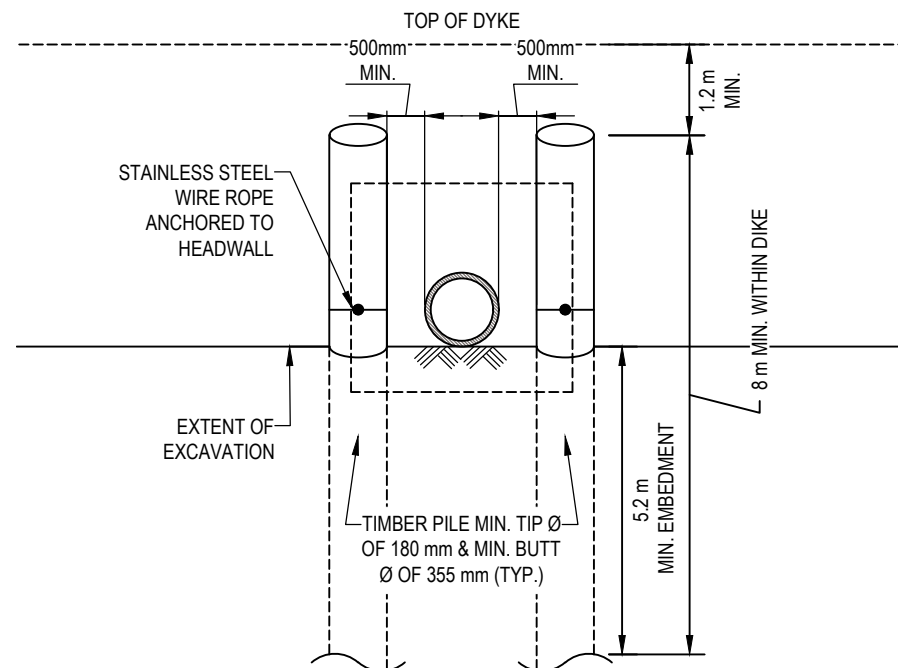

3 ANCHOR PILE INSTALLATION DETAIL
C1.01 N.T.S.

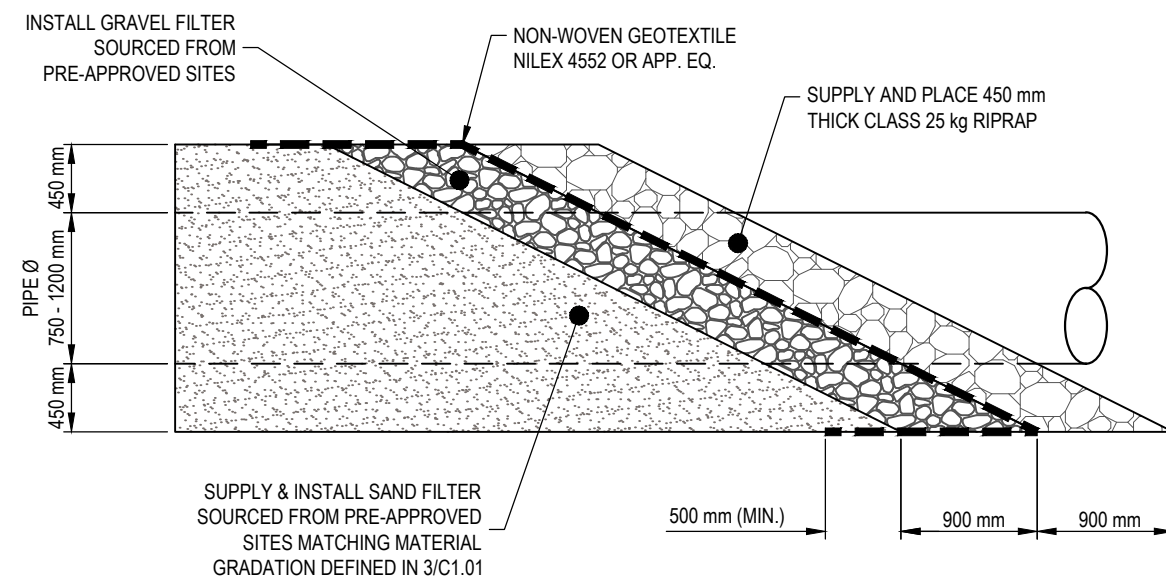

4 GRANULAR FILL SEQUENCE
C1.01 N.T.S.

NUM	DATE	DWN	CKD	APR	DESCRIPTION	NUM	DATE	APR	DESCRIPTION	
A	12/20/2019	HW	JW	DM	ISSUED FOR REVIEW					
					REVISIONS					
					DESCRIPTION					
					NUM	DATE	APR	DRAWING STATUS		

 	SURREY LOWLANDS FLOOD BOXES SURREY, B.C.			
	FLOOD BOX INSTALLATION			
PROJECT No. V13203062-02	OFFICE VANC	DES DM	OKD JW	REV A
DATE: December 20, 2019	SHEET No. 2 of 3	DWN HW	APP DM	STATUS IFR
				C1.01

SCHEDULE OF MATERIALS (HEADWALL TO PIPE CONNECTION)									
NOMINAL SIZE (mm)	PIPE	PIPE OD	PIPE JOINT SYSTEM	KOR-N-SEAL			LANGLEY CONCRETE		FONTAINE
				CONNECTOR MODEL	PIPE OD RANGE	HEADWALL OPENING RANGE	HEADWALL SPECIFIED OPENING	HEADWALL MODEL	FLAP GATE MODEL
750	BOSS 2000 + SLEEVE	908	ULTRA STAB 75	S206-40	905-939	1017-1021	1019	SD-337	60-42-A-CW-20
	ALL ALUMINUM (68x13 mm CORRUGATION)	786	600 mm ANNULAR COUPLER WITH NEOPRENE GASKET	S206-34	753-787	864-868	866	SD-334	60-36-A-CW-20
	ALL ALUMINUM + SLEEVE (REF.TO 6/C1.00)	794	600 mm ANNULAR COUPLER WITH NEOPRENE GASKET	S206-34L	788-803	864-868	866	SD-334	60-36-A-CW-20
	DURROMAXX	785	HIGH PERFORMANCE (HP) JOINT	S206-34	753-787	864-868	866	SD-334	60-36-A-CW-20
	DUROMAXX + SLEEVE	798	HIGH PERFORMANCE (HP) JOINT	S206-34L	788-803	864-869	866	SD-334	60-36-A-CW-20
900	BOSS 2000 + SLEEVE	1100	ULTRA STAB 75	S206-46L	1093-1108	1169-1173	1171	SD-336	60-48-A-CW-20
	ALL ALUMINUM (68x13 mm CORRUGATION)	938	600 mm ANNULAR COUPLER WITH NEOPRENE GASKET	S206-40	905-939	1017-1021	1019	SD-337	60-42-A-CW-20
	ALL ALUMINUM + SLEEVE (REF.TO 6/C1.00)	946	600 mm ANNULAR COUPLER WITH NEOPRENE GASKET	S206-40L	940-955	1017-1021	1019	SD-337	60-42-A-CW-20
	DURROMAXX	942	HIGH PERFORMANCE (HP) JOINT	S206-40L	940-955	1017-1021	1019	SD-337	60-42-A-CW-20
	DUROMAXX + SLEEVE	955	HIGH PERFORMANCE (HP) JOINT	S206-40L	940-955	1017-1021	1019	SD-337	60-42-A-CW-20
1200	ALL ALUMINUM (76x25 mm CORRUGATION)	1260	600 mm ANNULAR COUPLER WITH NEOPRENE GASKET	S206-54	1245-1260	1372-1377	1375	SD-338	60-56-A-CW-20
	ALL ALUMINUM + SLEEVE (REF.TO 6/C1.00)	1268	600 mm ANNULAR COUPLER WITH NEOPRENE GASKET	S206-54L	1261-1295	1372-1377	1375	SD-338	60-56-A-CW-20
	DURROMAXX	1257	HIGH PERFORMANCE (HP) JOINT	S206-54	1245-1260	1372-1377	1375	SD-338	60-56-A-CW-20
	DUROMAXX + SLEEVE	1270	HIGH PERFORMANCE (HP) JOINT	S206-54L	1261-1295	1372-1377	1375	SD-338	60-56-A-CW-20

- FOR LANGLEY CONCRETE HEADWALL SHOP DRAWINGS REFER TO ISSUE FROM DEC 09, 2019
- "SLEEVE" REFERS TO THE SUPPLIER ADAPTER FROM HELICAL WOUND EXTERIOR TO SMOOTHED WALLED EXTERIOR TO FACILITATE ATTACHEMENT TO THE KOR-N-SEAL BAND. SEE DETAIL 6/C1.00.
- MATERIAL SUPPLIERS TO PROVIDE SHOP DRAWINGS FOR APPROVAL BEFORE MANUFACTURING.
- CONTRACTOR TO CONFIRM MATERIAL DIMENSIONS IS CONSISTENT WITH SPECIFIED COUPLERS. (DIMENSIONS MAY VARY)

1. GENERAL NOTES

- CONTRACTOR TO REMOVE AND DISPOSE OFFSITE ALL EXISTING PILES, HEADWALLS AND PIPES.
- THE LOCATIONS OF EXISTING UNDERGROUND UTILITIES HAVE NOT BEEN INDEPENDENTLY VERIFIED BY THE OWNER OR ITS REPRESENTATIVE. THE CONTRACTOR SHALL DETERMINE THE EXACT LOCATION OF ALL EXISTING UTILITIES BEFORE COMMENCING WORK AND AGREES TO BE FULLY RESPONSIBLE FOR ANY AND ALL DAMAGES WHICH MIGHT OCCUR BY THE CONTRACTOR'S FAILURE TO LOCATE ANY AND ALL UNDERGROUND UTILITIES.
- CONTRACTOR TO PROVIDE A SEDIMENT & EROSION CONTROL PLAN.
- CONTRACTOR IS ENCOURAGED TO INSTALL THE FLOODBOX OUTFALL DURING LOW TIDES TO LIMIT THE AMOUNT OF EFFORT NEEDED TO DEWATER THE SITE. SUMP PUMP DEWATERING IS LIKELY REQUIRED DURING THE EXCAVATION. USE OF SHEET PILES IS RECOMMENDED TO ISOLATE THE CONSTRUCTION SITE.

2. GENERAL EXCAVATION & COMPACTION

- A MINIMUM OF 500 mm CLEARANCE IS RECOMMENDED BETWEEN THE EXCAVATION SIDE SLOPES AND THE FLOODBOX TO ALLOW FOR ACCESS, PLACEMENT AND COMPACTION OF BACKFILL.
- CONTRACTOR TO PROTECT STOCKPILES FROM RAINFALL
- CONTRACTOR TO HAVE WALK-BEHIND COMPACTOR OR JUMPING JACK AVAILABLE ON-SITE TO COMPACT COARSE GRAINED SAND/GRAVEL FILTERS IF NECESSARY.

3. CITY OF SURREY SUPPLIED MATERIALS

- MATERIAL SUPPLIED BY THE CITY WILL BE DELIVERED TO THE CLOSEST INTERSECTION BETWEEN THE RIVER & THE CLOSEST PUBLIC ROAD. THE CONTRACTOR WILL BE RESPONSIBLE FOR TRANSPORTING THE SUPPLIED MATERIAL TO ITS FINAL DESTINATION..

4. PIPE

- INSTALLATION OF PIPES TO BE CARRIED OUT IN ACCORDANCE WITH MANUFACTURER'S SPECIFICATIONS AND RECOMMENDATIONS.
- AIL ALUMINUM PIPE TO BE SUPPLIED WITH ALUMINUM SLEEVE ON ONE PIPE SEGMENT TO CONNECT TO KOR-N-SEAL CONNECTION. SEE DETAIL 7/C1.00.

5. PRECAST HEADWALL

- HEADWALLS SUPPLIED TO BE 2.1 m x 1.8 m x 2.0 m CUSTOM SURREY LOWLANDS FLOOD BOX HEADWALL C/W KOR-N-SEAL II 206 SERIES CONNECTOR, CRADLE, STOP-LOGS, AND FLAP GATE.
- HEADWALL OPENING VARIES TO SUITE SUPPLIED PIPE
- INSTALLED FLAPGATE TO BE FONTAINE SERIES 60 FLAP GATE OR APPROVED HDPE EQUIVALENT.

6. GEOTEXTILE

- GEOTEXTILE TO BE INSTALLED WITH A MINIMUM OVERLAP OF 500 mm.



7. TIMBER PILE

- PILES TO BE INSTALLED WITHIN 2% OF VERTICAL WHILE BEING MONITORED BY A GEOTECHNICAL ENGINEER.

8. DIKE MATERIAL

- SELECT NATIVE FILL MATERIAL IS TO BE USED FOR BACKFILL.
- WHERE NATIVE MATERIAL IS UNSUITABLE FOR COMPACTION, CONTRACTOR IS TO REQUEST APPROVED IMPORT DIKE MATERIAL FROM THE CITY OF SURREY.

REV	DATE	BY	CHKD	APP	DESCRIPTION	NUM	DATE	BY	CHKD	APP	DESCRIPTION
A	12/20/2019	MJK	JW	DM	ISSUED FOR REVIEW						
REVISIONS						DRAWING STATUS					

 	SURREY LOWLANDS FLOOD BOXES SURREY, B.C.				
	FLOOD BOX INSTALLATION				
PROJECT No. V13203062-02	OFFICE VANC	DES DM	OKD JW	REV A	C1.02
DATE: December 20, 2019	SHEET No. 3 of 3	DWN MJK	APP DM	STATUS IFR	

**SCHEDULE A-2
MAPS
FLOOD BOX LOCATIONS**



US-1542-R

Scale: 1:2,000

The data provided is compiled from various sources and is NOT warranted as to its accuracy or sufficiency by the City of Surrey. This information is provided for information and convenience purposes only. Lot sizes, legal descriptions and encumbrances must be confirmed at the Land Title Office. Use and distribution of this map is subject to all copyright and disclaimer notices at cosmos.surrey.ca

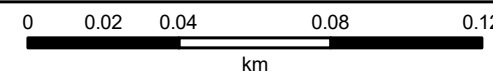

Map created on: 2022-11-28



MS-12942-L

Scale: 1:2,365

The data provided is compiled from various sources and is NOT warranted as to its accuracy or sufficiency by the City of Surrey. This information is provided for information and convenience purposes only. Lot sizes, legal descriptions and encumbrances must be confirmed at the Land Title Office. Use and distribution of this map is subject to all copyright and disclaimer notices at cosmos.surrey.ca

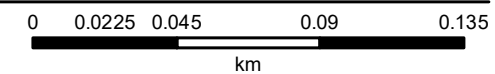

Map created on: 2022-11-28



LN-5727-R (Optional)

Scale: 1:3,941

The data provided is compiled from various sources and is NOT warranted as to its accuracy or sufficiency by the City of Surrey. This information is provided for information and convenience purposes only. Lot sizes, legal descriptions and encumbrances must be confirmed at the Land Title Office. Use and distribution of this map is subject to all copyright and disclaimer notices at cosmos.surrey.ca

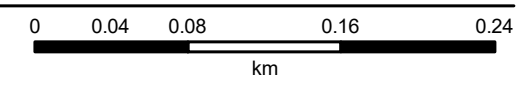

Map created on: 2022-11-28

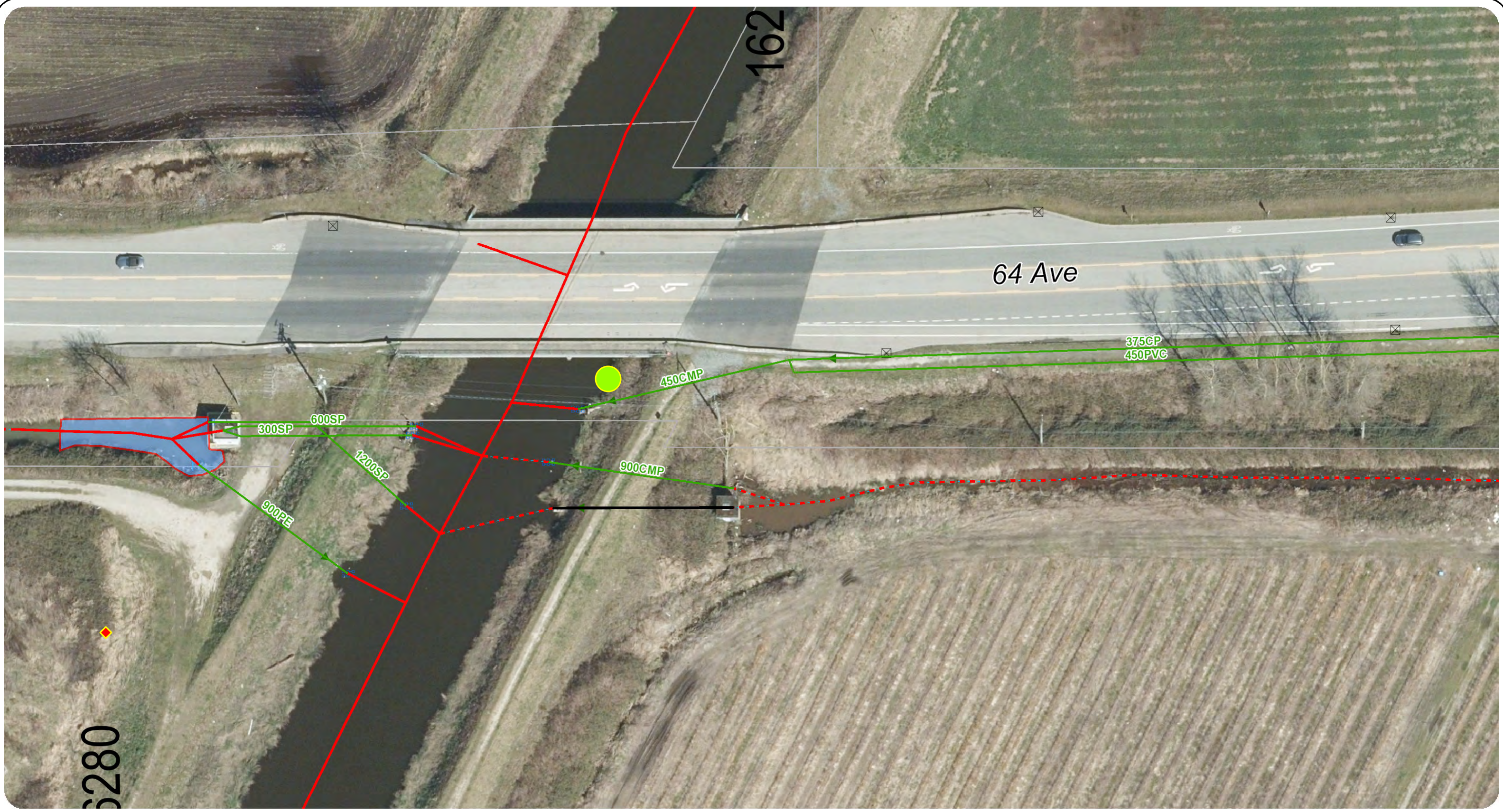

MS-9889-L

Scale: 1:541

The data provided is compiled from various sources and is NOT warranted as to its accuracy or sufficiency by the City of Surrey. This information is provided for information and convenience purposes only. Lot sizes, legal descriptions and encumbrances must be confirmed at the Land Title Office. Use and distribution of this map is subject to all copyright and disclaimer notices at cosmos.surrey.ca

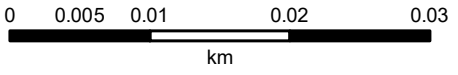

Map created on: 2022-02-09

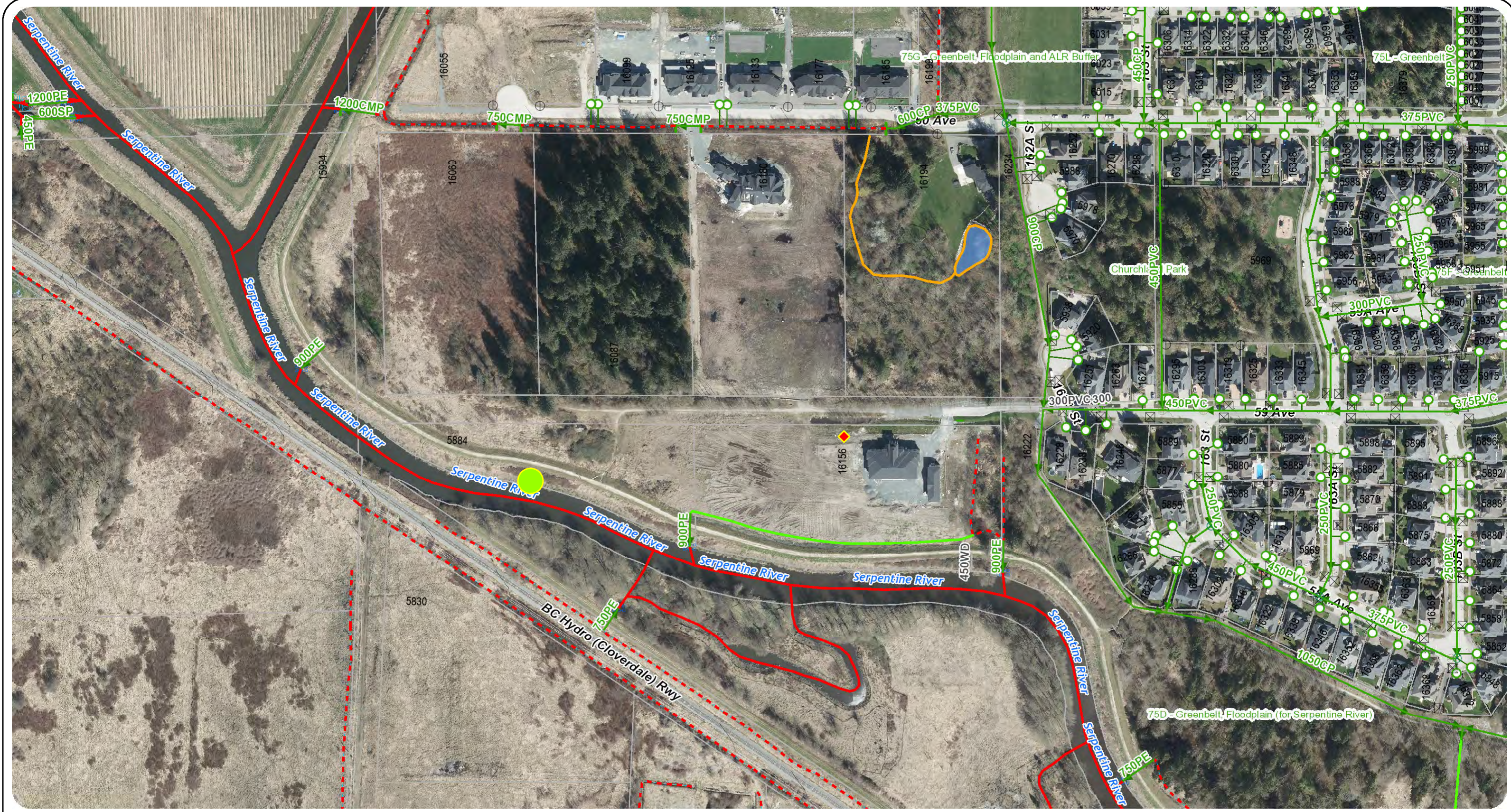

MS-8282-L

Scale: 1:2,503

The data provided is compiled from various sources and is NOT warranted as to its accuracy or sufficiency by the City of Surrey. This information is provided for information and convenience purposes only. Lot sizes, legal descriptions and encumbrances must be confirmed at the Land Title Office. Use and distribution of this map is subject to all copyright and disclaimer notices at cosmos.surrey.ca

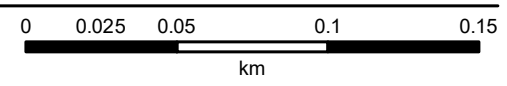

Map created on: 2022-02-09

SCHEDULE B – DRAFT CONTRACT



PROFESSIONAL SERVICES AGREEMENT

Title: Engineering Services for Inspection of Flood Box Construction

Reference No.: 1220-030-2023-001

TABLE OF CONTENTS

- 1. INTERPRETATION.....**
 - 1.1 Definitions.....
 - 1.2 Appendices.....

- 2. SERVICES.....**
 - 2.1 Goods and Services
 - 2.2 Amendment of Goods and Services
 - 2.3 Additional Goods and Services
 - 2.4 Standard of Care
 - 2.5 Term
 - 2.6 Time
 - 2.7 Warranty of Goods.....
 - 2.8 Pandemic Restrictions

- 3. PERSONNEL.....**
 - 3.1 Qualified Personnel
 - 3.2 Listed Personnel and Sub-Contractors
 - 3.3 Replacement of Personnel or Sub-Contractors.....
 - 3.4 Sub-Contractors and Assignment
 - 3.5 Agreements with Sub-Contractors

- 4. LIMITED AUTHORITY.....**
 - 4.1 Agent of City.....
 - 4.2 Independent Contractor

- 5. FEES.....**
 - 5.1 Payment for Goods and Services
 - 5.2 Payment
 - 5.3 Records.....
 - 5.4 Goods not listed in Appendix 2
 - 5.5 Units of Goods and Services
 - 5.6 Personnel Hourly Rates.....
 - 5.7 Equipment Hourly Rates.....
 - 5.8 Incidental Goods Supply.....
 - 5.9 Non-Residents.....

- 6. CITY RESPONSIBILITIES.....**
 - 6.1 City Information
 - 6.2 City Decisions.....
 - 6.3 Notice of Defect.....

- 7. INSURANCE AND DAMAGES.....**

7.1	Indemnity.....
7.2	Survival of Indemnity
7.3	Contractor’s Insurance Policies.....
7.4	Insurance Requirements.....
7.5	Contractor Responsibilities
7.6	Additional Insurance
7.7	Waiver of Subrogation
8.	TERMINATION
8.1	By the City.....
8.2	Termination for Cause
8.3	Curing Defaults.....
9.	APPLICABLE LAWS, POLICIES, BUILDING CODES AND BY-LAWS
9.1	Applicable Laws and Policies.....
9.2	Codes and By-Laws.....
9.3	Interpretation of Codes
10.	CONFIDENTIALITY AND DISCLOSURE OF INFORMATION.....
10.1	No Disclosure
10.2	Freedom of Information and Protection of Privacy Act
10.3	Return of Property
11.	USE OF WORK PRODUCT
12.	WORKERS’ COMPENSATION BOARD, AND OCCUPATIONAL HEALTH AND SAFETY
13.	BUSINESS LICENSE.....
14.	DISPUTE RESOLUTION
14.1	Dispute Resolution Procedures.....
15.	JURISDICTION AND COUNCIL NON-APPROPRIATION.....
16.	GENERAL.....
16.1	Entire Contract.....
16.2	Amendment
16.3	Contractor Terms Rejected.....
16.4	Survival of Obligations
16.5	Cumulative Remedies.....
16.6	Notices
16.7	Unenforceability.....
16.8	Headings

16.9 Singular, Plural and Gender.....
16.10 Waiver
16.11 Signature
16.12 Enurement.....
16.13 Compliance with COVID-19 Policy.....

APPENDIX 1 – SPECIFICATIONS OF GOODS AND SCOPE OF SERVICES

APPENDIX 1-A LOW LAND FLOOD BOX DESIGN

APPENDIX 1-B MAPS

APPENDIX 2 – FEES AND PAYMENT

APPENDIX 3 – TIME SCHEDULE

APPENDIX 4 – PERSONNEL AND SUB-CONTRACTORS

APPENDIX 5 – ADDITIONAL SERVICES

ENGINEERING SERVICES FOR INSPECTION OF FLOOD BOX CONSTRUCTION

THIS AGREEMENT is dated for reference this _____ day of _____, 202_.

AGREEMENT No.: 1220-030-2023-001

BETWEEN:

CITY OF SURREY
13450 - 104 Avenue
Surrey, B.C., V3T 1V8, Canada
(the “**City**”)

AND:

(Insert Full Legal Name and Address of Contractor)

(the “**Contractor**”)

WHEREAS the City wishes to engage the Contractor to provide the Goods and Services and the Contractor agrees to provide the Goods and Services.

Engineering Services OF Inspection of Flood Box Construction

THEREFORE in consideration of the premises and payment of one (\$1.00) dollar and other good and valuable consideration paid by each of the parties to the other (the receipt and sufficiency of which each party hereby acknowledges), the parties hereby covenant and agree with each other as follows:

1. INTERPRETATION

1.1 Definitions

In this agreement the following definitions apply:

- (a) “**Disbursements**” has the meaning set out in Section 5.3;
- (b) “**Dispute**” has the meaning set out in Section 14.1;
- (c) “**Fees**” has the meaning set out in Section 5.1;
- (d) “**Goods**” has the meaning set out in Section 2.1;
- (e) “**Indemnitees**” has the meaning set out in Section 7.1;
- (f) “**Invoice**” has the meaning set out in Section 5.2(a)
- (g) “**Services**” has the meaning set out in Section 2.1;

- (h) **“Term”** has the meaning set out in Section 2.5; and
- (i) **“Time Schedule”** has the meaning set out in Section 2.6.

1.2 This agreement may be modified only by express and specific written agreement. In the event of a conflict between the provisions of any documents listed below, then the documents shall govern and take precedence in the following order:

- (a) this agreement;
- (b) Appendix 1, 2, 3, 4 and 5; and
- (c) other terms, if any, that are agreed to by the parties in writing.

1.3 The following attached Appendices are a part of this agreement:

- (a) Appendix 1 – Specifications of Goods and Scope of Services;
- (b) Appendix 1-A Drawings;
- (c) Appendix 1-B Maps;
- (d) Appendix 2 – Fees and Payment;
- (e) Appendix 3 – Time Schedule;
- (f) Appendix 4 – Personnel and Sub-Contractors; and
- (g) Appendix 5 – Additional Services.

2. GOODS AND SERVICES

2.1 Goods and Services

The City hereby retains the Contractor to provide the Goods and Services as described generally in Appendix 1, including anything and everything required to be done for the fulfillment and completion of this agreement (the **“Goods and Services”**).

2.2 Amendment of Goods and Services

The City may from time to time, by written notice to the Contractor, make changes to the Goods and Services. The Fees will be increased or decreased by written agreement of the City and the Contractor according to the rates set out in Appendix 2.

2.3 Additional Goods and Services

The Contractor will, if requested in writing by the City, provide additional goods and perform additional services as may be listed in Appendix 5. The terms of this agreement will apply to any additional goods and services, and the fees for additional goods and services, and the time for the Contractor’s performance, will generally correspond to the fees and time of performance as described in Appendices 2 and 3. The Contractor will not provide any additional goods and services in excess of the scope of services requested in writing by the City.

2.4 Standard of Care

The Contractor will provide the Goods and perform the Services with that degree of care, skill and diligence normally provided by a qualified and experienced practitioner. The Contractor represents that it has the expertise, qualifications, resources and relevant experience to provide the Goods and Services.

2.5 Term

The Contractor will provide the Goods and Services for the period commencing on (**START DATE**) and terminating on (**END DATE**) (the "**Term**").

The parties may extend the Term by mutual agreement. If the Term is extended, the provisions of this agreement will remain in force except where amended in writing by the parties.

2.6 Time

The Contractor acknowledges that time is of the essence with respect to the provision of the Goods and Services and accordingly the Contractor will provide the Goods and Services within the performance or completion dates or time periods (the "**Time Schedule**") as set out in Appendix 3, or as otherwise agreed to in writing by the City and the Contractor. If at any time the Contractor discovers that the Time Schedule cannot be met it will immediately advise the City in writing and provide a revised Time Schedule.

2.7 Warranty of Goods

The Contractor warrants that the Goods supplied by the Contractor shall be free from defects in design, materials, workmanship and title, shall conform in all respects to the terms of this agreement, shall be fit and suitable and perform satisfactorily for the purposes and under the conditions made known to the Contractor by the City. The Goods shall be of the best quality, if no quality is specified. This general warranty is independent of and without prejudice to any specific warranty or service guarantee offered by the Contractor or third party manufacturer or supplier of the Goods in connection with the purpose for which the Goods were purchased.

The Contractor shall assign to the City any warranty or service guarantee offered by a third party manufacturer or supplier of the Goods. Notwithstanding this assignment, if at any time up to one year from the date of delivery or installation (if applicable) the City determines the Goods or any part do not conform to these warranties, the City shall notify the Contractor within a reasonable time after such discovery, and the Contractor shall then promptly correct such nonconformity at the Contractor's expense. Goods used to correct a nonconformity shall be similarly warranted for one year from the date of installation. The Contractor's liability shall extend to all liabilities, losses, damages, claims and expenses incurred by the City caused by any breach of any of the above warranties.

Goods supplied by the City and installed by the Contractor that require Services during a product warranty period shall be serviced by the Contractor at the City's expense.

If any Goods are installed by the Contractor, and subsequently recalled by the manufacturer of the Goods, Service costs associated with the replacement of the recalled Goods will be at the

Contractor's expense. The Contractor shall notify the City if a recall notice is issued by a Goods manufacturer.

Damage to Goods caused by a third party (i.e., motor vehicle collision) shall not be covered by any Goods warranty, and the Contractor will not be held responsible for any associated damage repair costs.

2.8 Pandemic Restrictions

The parties acknowledge that this agreement has been entered into during the on-going COVID-19 pandemic (the "**Pandemic**"). The Contractor advises that it is able to proceed to provide the Goods and perform with the Services under the Pandemic conditions and restrictions (collectively the "**Pandemic Restrictions**") as they exist as of the date of this agreement. The parties acknowledge that Pandemic Conditions may change so as to cause unavoidable interruptions or interference to the Contractor's performance of the Goods and Services. The parties confirm:

- (a) notwithstanding the known existence of the Pandemic, Section 2.8 will apply to new Pandemic Restrictions, which arise after the date of this agreement, whether anticipated or not, which reasonably interfere with the Contractor providing the Goods and performance of the Services, such that upon the Contractor giving required notice shall be entitled to an extension of the time to provide the Goods and perform the Services, but shall not be entitled to reimbursement of any costs;
- (b) notwithstanding any such new Pandemic Restrictions, the agreement will remain valid and in force, subject to the terms of the agreement including, without limitation Section 12 (Workers' Compensation Board and Occupational Health and Safety); and
- (c) if new Pandemic Restrictions occur that cause or threaten interruption of the Goods and Services the Contractor will give the City immediate notice, and a written plan of the interim steps the Contractor will take, if any, during the interruption of the Goods and Services, and when Pandemic Restrictions permit, provide the City with a written plan for the resumption of the Goods and Services.

3. PERSONNEL

3.1 Qualified Personnel

The Contractor will provide only professional personnel who have the qualifications, experience and capabilities to provide the Goods and perform the Services.

3.2 Listed Personnel and Sub-Contractors

The Contractor will provide the Goods and Services using the professional personnel and sub-contractors as may be listed in Appendix 4 and identified by the Contractor, and the Contractor will not remove any such listed personnel or sub-contractors from the Goods and Services without the prior written approval of the City.

3.3 Replacement of Personnel or Sub-Contractors

If the City reasonably objects to the performance, qualifications, experience or suitability of any of the Contractor's personnel or sub-contractors then the Contractor will, on written request from the City, replace such personnel or sub-contractors.

3.4 Sub-Contractors and Assignment

Except as provided for in Section 3.2, the Contractor will not engage any personnel or sub-contractors, or sub-contract or assign its obligations under this agreement, in whole or in part, without the prior written approval of the City.

3.5 Agreements with Sub-Contractors

The Contractor will preserve and protect the rights of the City with respect to any Services performed under sub-contract and incorporate the terms and conditions of this agreement into all sub-contracts as necessary to preserve the rights of the City under this agreement. The Contractor will be as fully responsible to the City for acts and omissions of sub-contractors and of persons directly or indirectly employed by them as for acts and omissions of persons directly employed by the Contractor.

4. LIMITED AUTHORITY

4.1 Agent of City

The Contractor is not and this agreement does not render the Contractor an agent or employee of the City, and without limiting the above, the Contractor does not have authority to enter into any contract or reach any agreement on behalf of the City, except for the limited purposes as may be expressly set out in this agreement, or as necessary in order to provide the Goods and Services. The Contractor will make such lack of authority clear to all persons with whom the Contractor deals in the course of providing the Goods and Services. Every vehicle used by the Contractor in the course of providing the Goods and Services shall identify the Contractor by name and telephone number.

4.2 Independent Contractor

The Contractor is an independent contractor. This agreement does not create the relationship of employer and employee, a partnership, or a joint venture. The City will not control or direct the details, means or process by which the Contractor performs the Goods and Services. The Contractor will determine the number of days and hours of work required to properly and completely perform the Goods and Services. The Contractor is primarily responsible for performance of the Goods and Services and may not delegate or assign any Goods or Services to any other person except as provided for in Section 3.4. The Contractor will be solely liable for the wages, fringe benefits, work schedules and work conditions of any partners, employees or sub-contractors.

5. FEES

5.1 Payment for Goods and Services

The City will pay to the Contractor the fees as set out in Appendix 2 (the "Fees"). Payment by the City of the Fees will be full payment for the Goods and Services and the Contractor will not be entitled to receive any additional payment from the City.

5.2 Payment

Subject to any contrary provisions set out in this Agreement:

- (a) the Contractor will submit an invoice (the "Invoice") to the City requesting payment of the portion of the Fees relating to the Goods and Services provided. Each Invoice should be sent **electronically** to: surreyinvoices@surrey.ca and include the following information:
 - (1) an invoice number;
 - (2) the Contractor's name, address and telephone number;
 - (3) the City's reference number for the Goods and Services; P.O. # (to be advised)
 - (4) the names, charge-out rates and number of hours worked in the previous month of all employees of the Contractor and any sub-contractors that have performed services during the previous month;
 - (5) the percentage of the Goods and Services completed at the end of the previous month;
 - (6) the total budget for the Goods and Services and the amount of the budget expended to the date of the Invoice;
 - (7) taxes (if any);
 - (8) grand total of the Invoice;
- (b) if the City reasonably determines that any portion of an Invoice is not payable then the City will so advise the Contractor;
- (c) the City will pay the portion of an Invoice which the City determines is payable less any deductions for setoffs or holdbacks permitted by this agreement including, without limitation, any amounts permitted to be held back on account of deficiencies, within 30 days of the receipt of the Invoice;
- (d) if the Contractor offers the City a cash discount for early payment, then the City may, at the City's sole discretion, pay the discounted portion of an Invoice; and
- (f) all Invoices shall be stated in, and all payments made in, Canadian dollars.

5.3 Records

The Contractor will prepare and maintain proper records related to the delivery of the Goods and Services, including records, receipts and invoices relating to Disbursements. On request from the City, the Contractor will make the records available open to audit examination by the City at any time during regular business hours during the time the Contractor is providing the Goods and Services and for a period of six years after the Goods are delivered and the Services are complete.

5.4 Goods not listed in Appendix 2

All replacement Goods not specifically listed in Appendix 2 but required will be supplied by the Contractor and invoiced to the City at cost plus insert percentage discount (___%).> The Contractor shall submit, upon request by the City, actual supplier's invoices to establish the cost of the Goods.

5.5 Units of Goods and Services

The estimated units of Goods and Services in Appendix 2 are for determination of the price only. The City does not guarantee that the actual amounts of Goods and Services of any unit class will correspond even approximately to the estimated units, but reserves the right to increase or decrease the amounts of any class or portion of the Goods and Services, or to omit portions of the Goods and Services that may be deemed necessary or expedient by the City. The Contractor shall make no claim for anticipated profits, for loss of profit, for damages, or for any extra payment whatsoever, because of any difference between the amount of actual Goods and Services furnished and the quantities stated in Appendix 2.

5.6 Personnel Hourly Rates

The personnel hourly rates in Appendix 2 shall include all overhead, profit and all small tools and other miscellaneous equipment normally required by tradesmen in their provision of the Goods and Services. No payment will be made for travel time to and from each Site and such time shall not be included in the time measured for payment.

5.7 Equipment Hourly Rates

The equipment hourly rates in Appendix 2 shall include all overhead, profit and shall include operators, fuel, repairs, moving charges, etc. Time required for transportation of equipment to and from work sites within Surrey will be payable at the appropriate equipment hourly rates. Payment for time required to transport equipment into and out of the City's jurisdictional boundaries will not be payable.

5.8 Incidental Goods Supply

Goods provided to aid or assist in maintenance tasks and/or installation of new or replacement parts shall be considered incidental, and shall not be paid for separately by the City under Appendix 2.

5.9 Non-Residents

If the Contractor is a non-resident of Canada and does not provide to the City a waiver of regulation letter, the City will withhold and remit to the appropriate governmental authority the greater of:

- (a) 15% of each payment due to the Contractor; or
- (b) the amount required under applicable tax legislation.

6. CITY RESPONSIBILITIES

6.1 City Information

The City will, in co-operation with the Contractor, make efforts to make available to the Contractor information, surveys, reports and records which the City has in its possession that relate to the delivery of the Goods and Services. The Contractor will review any such material upon which the Contractor intends to rely and take reasonable steps to determine if that information is complete or accurate. The Contractor will assume all risks that the information is complete and accurate and the Contractor will advise the City in writing if in the Contractor's judgment the information is deficient or unreliable and undertake such new surveys and investigations as are necessary.

6.2 City Decisions

The City will in a timely manner make all decisions required under this agreement, examine documents submitted by the Contractor and respond to all requests for approval made by the Contractor pursuant to this agreement.

6.3 Notice of Defect

If the City observes or otherwise becomes aware of any fault or defect in the delivery of the Goods or the provision of Services, it may notify the Contractor, but nothing in this agreement will be interpreted as giving the City the obligation to inspect or review the Contractor's performance with regards to delivering Goods or the provision of the Services.

7. INSURANCE AND DAMAGES

7.1 Indemnity

The Contractor will indemnify and save harmless the City and all of its elected and appointed officials, officers, employees, servants, representatives and agents (collectively the "Indemnitees"), from and against all claims, demands, causes of action, suits, losses, damages and costs, liabilities, expenses and judgments (including all actual legal costs) for damage to or destruction or loss of property, including loss of use, and injury to or death of any person or persons which any of the Indemnitees incur, suffer or are put to arising out of or in connection with any failure, breach or non-performance by the Contractor of any obligation of this agreement, or any wrongful or negligent act or omission of the Contractor or any employee or agent of the Contractor.

7.2 Survival of Indemnity

The indemnity described in this Contract will survive the termination or completion of this agreement and, notwithstanding such termination or completion, will continue in full force and effect for the benefit of the Indemnitees.

7.3 Contractor's Insurance Policies

The Contractor will, without limiting its obligations or liabilities and at its own expense, provide and maintain throughout this agreement the following insurances in forms and amounts acceptable to the City from insurers licensed to conduct business in Canada:

- (a) commercial general liability insurance on an occurrence basis, in an amount not less than five million (\$5,000,000) dollars inclusive per occurrence against death, bodily injury and property damage arising directly or indirectly out of the work or operations of the Contractor, its employees and agents. The insurance will include cross liability and severability of interests such that the coverage shall apply in the same manner and to the same extent as though a separate policy had been issued to each insured. The insurance will include, but not be limited to: premises and operators liability, broad form products and completed operations, owners and contractors protective liability, blanket contractual, employees as additional insureds, broad form property damage, non-owned automobile, contingent employers liability, broad form loss of use, personal injury, and incidental medical malpractice. The City will be added as additional insured;
- (b) professional errors and omissions insurance in an amount not less two million (\$2,000,000) dollars insuring all professionals providing the Services from liability resulting from errors or omissions in the performance of the Services, with a 12-month maintenance period, and
- (c) automobile liability insurance on all vehicles owned, operated or licensed in the name of the Contractor in an amount not less than three million (\$3,000,000) dollars per occurrence for bodily injury, death and damage to property.

7.4 Insurance Requirements

The Contractor will provide the City with evidence of the required insurance prior to the commencement of this agreement. Such evidence will be in the form of a completed certificate of insurance acceptable to the City. The Contractor will, on request from the City, provide certified copies of all of the Contractor's insurance policies providing coverage relating to the Services, including without limitation any professional liability insurance policies. All required insurance will be endorsed to provide the City with thirty (30) days advance written notice of cancellation or material change restricting coverage. To the extent the City has an insurable interest, the builder's risk policy will have the City as first loss payee. The Contractor will be responsible for deductible amounts under the insurance policies. All of the Contractor's insurance policies will be primary and not require the sharing of any loss by the City or any insurer of the City.

7.5 Contractor Responsibilities

The Contractor acknowledges that any requirements by the City as to the amount of coverage under any policy of insurance will not constitute a representation by the City that the amount required is adequate and the Contractor acknowledges and agrees that the Contractor is solely responsible for obtaining and maintaining policies of insurance in adequate amounts. The insurance policy coverage limits shall not be construed as relieving the Contractor from responsibility for any amounts which may exceed these limits, for which the Contractor may be legally liable.

7.6 Additional Insurance

The Contractor shall place and maintain, or cause any of its sub-contractors to place and maintain, such other insurance or amendments to the foregoing policies as the City may reasonably direct.

7.7 Waiver of Subrogation

The Contractor hereby waives all rights of recourse against the City for loss or damage to the Contractor's property.

8. TERMINATION

8.1 By the City

The City may at any time and for any reason by written notice to the Contractor terminate this agreement before the completion of all the Goods and Services, such notice to be determined by the City at its sole discretion. Upon receipt of such notice, the Contractor will perform no further Goods and Services other than the work which is reasonably required to complete the Goods and Services. Despite any other provision of this agreement, if the City terminates this agreement before the completion of all the Goods and Services, the City will pay to the Contractor all amounts owing under this agreement for Goods and Services provided by the Contractor up to and including the date of termination, plus reasonable termination costs in the amount as determined by the City in its sole discretion. Upon payment of such amounts no other or additional payment will be owed by the City to the Contractor, and, for certainty, no amount will be owing on account of lost profits relating to the portion of the Goods and Services not performed or other profit opportunities.

8.2 Termination for Cause

The City may terminate this agreement for cause as follows:

- (a) If the Contractor is adjudged bankrupt, or makes a general assignment for the benefit of creditors because of its insolvency, or if a receiver is appointed because of its insolvency, the City may, without prejudice to any other right or remedy the City may have, terminate this agreement by giving the Contractor or receiver or trustee in bankruptcy written notice; or

- (b) If the Contractor is in breach of any term or condition of this agreement, and such breach is not remedied to the reasonable satisfaction of the City within 5 days after delivery of written notice from the City to the Contractor, then the City may, without prejudice to any other right or remedy the City may have, terminate this agreement by giving the Contractor further written notice.

If the City terminates this Contract as provided by this Section, then the City may:

- (a) enter into contracts, as it in its sole discretion sees fit, with other persons to complete the Goods and Services;

- (b) withhold payment of any amount owing to the Contractor under this agreement for the performance of the Goods and Services;

- (c) set-off the total cost of completing the Goods and Services incurred by the City against any amounts owing to the Contractor under this agreement, and at the completion of the Goods and Services pay to the Contractor any balance remaining; and

- (d) if the total cost to complete the Goods and Services exceeds the amount owing to the Contractor, charge the Contractor the balance, which amount the Contractor will forthwith pay.

8.3 Curing Defaults

If the Contractor is in default of any of its obligations under this agreement, then the City may without terminating this agreement, upon 5 days written notice to the Contractor, remedy the default and set-off all costs and expenses of such remedy against any amounts owing to the Contractor. Nothing in this agreement will be interpreted or construed to mean that the City has any duty or obligation to remedy any default of the Contractor.

9. APPLICABLE LAWS, POLICIES, BUILDING CODES AND BY-LAWS

9.1 Applicable Laws and City Policies

This agreement will be governed by and construed in accordance with the laws of the Province of British Columbia. The City and the Contractor accept the jurisdiction of the courts of British Columbia and agree that any action under this agreement be brought in such courts.

The Contractor shall comply with all applicable policies, procedures and instructions provided by the City.

9.2 Codes and By-Laws

The Contractor will provide the Goods and Services in full compliance with all applicable laws, building codes and regulations.

9.3 Interpretation of Codes

The Contractor will, as a qualified and experienced professional, interpret applicable codes, laws and regulations applicable to the performance of the Goods and Services. If an authority having jurisdiction imposes an interpretation which the Contractor could not reasonably have verified or foreseen prior to entering into this agreement, then the City will pay the additional costs, if any, of making alterations so as to conform to the required interpretation.

10. CONFIDENTIALITY AND DISCLOSURE OF INFORMATION

10.1 No Disclosure

Except as provided for by law or otherwise by this agreement, the Contractor will keep strictly confidential any information supplied to, obtained by, or which comes to the knowledge of the Contractor as a result of the performance of the Goods and Services and this agreement, and will not, without the prior express written consent of the City, publish, release, disclose or permit to be disclosed any such information to any person or corporation, either before, during or after termination of this agreement, except as reasonably required to complete the Goods and Services.

10.2 Freedom of Information and Protection of Privacy Act

The Contractor acknowledges that the City is subject to the *Freedom of Information and Protection of Privacy Act* of British Columbia and agrees to any disclosure of information by the City required by law.

10.3 Return of Property

The Contractor agrees to return to the City all of the City's property at the completion of this agreement, including any and all copies or originals of reports provided by the City.

11. USE OF WORK PRODUCT

The Contractor hereby sells, assigns and transfers to the City the right, title and interest required for the City to use and receive the benefit of all the reports, drawings, plans, designs, models, specifications, computer software, concepts, products, designs or processes or other such work product produced by or resulting from the Services rendered by the Contractor.

12. WORKERS' COMPENSATION BOARD AND OCCUPATIONAL HEALTH AND SAFETY

- 12.1 The Contractor agrees that it shall, at its own expense, procure and carry, or cause to be procured, carried and paid for, full Workers' Compensation Board coverage for itself and all workers, employees, servants and others engaged in the supply of the Goods and Services. The Contractor agrees that the City has the unfettered right to set off the amount of the unpaid premiums and assessments for the Workers' Compensation Board coverage against any monies owing by the City to the Contractor. The City will have the right to withhold payment under this agreement until the Workers' Compensation Board premiums, assessments or penalties in respect of the Goods and Services have been paid in full.
- 12.2 The Contractor will provide the City with the Contractor's Workers' Compensation Board registration number and a letter from the Workers' Compensation Board confirming that the Contractor is registered in good standing with the Workers' Compensation Board and that all assessments have been paid to the date thereof prior to the City having any obligations to pay monies under this agreement.
- 12.3 The Contractor agrees that it is the prime contractor for the Services as defined in the *Workers Compensation Act, R.S.B.C. 2019, c.1*. The Contractor will have a safety program in place that meets the requirements of the Workers' Compensation Board Occupational Health and Safety Regulation and the *Workers Compensation Act*. As prime contractor, the Contractor will be responsible for appointing a qualified coordinator for insuring the health and safety activities for the location of the Services. That person will be the person so identified in this agreement, and the Contractor will advise the City immediately in writing if the name or contact number of the qualified coordinator changes.
- 12.4 Without limiting the generality of any other indemnities granted by the Contractor in this agreement, the Contractor shall indemnify and save harmless the Indemnitees from and against all claims, demands, causes of action, suits, losses, damages, costs, liabilities, expenses, judgements, penalties and proceedings (including all actual legal costs) which any of the Indemnitees incur, suffer or are put to arising out of or in any way related to

unpaid Workers' Compensation Board assessments owing from any person or corporation engaged in the performance of this agreement or arising out of or in any way related to the failure to observe safety rules, regulations and practices of the Workers' Compensation Board, including penalties levied by the Workers' Compensation Board.

- 12.5 The Contractor will ensure compliance with and conform to all health and safety laws, by-laws or regulations of the Province of British Columbia, including without limitation the *Workers Compensations Act* and Regulations pursuant thereto.
- 12.6 The City may, on twenty-four (24) hours written notice to the Contractor, install devices or rectify any conditions creating an immediate hazard existing that would be likely to result in injury to any person. However, in no case will the City be responsible to ascertaining or discovering, through inspections or review of the operations of the Contractor or otherwise, any deficiency or immediate hazard.
- 12.7 The Contractor understands and undertakes to comply with all Workers' Compensation Board Occupational Health and Safety Regulations for hazardous materials and substances, and in particular with the "Workplace Hazardous Materials Information System (WHMIS)" Regulations. All "Material Safety Data Sheets (MSDS)" shall be shipped along with the Goods and any future MSDS updates will be forwarded.

13. BUSINESS LICENSE

The Contractor will obtain and maintain throughout the term of this agreement a valid City of Surrey business license.

14. DISPUTE RESOLUTION

14.1 Dispute Resolution Procedures

The parties will make reasonable efforts to resolve any dispute, claim, or controversy arising out of this agreement or related to this agreement ("**Dispute**") using the dispute resolution procedures set out in this Section 14.

(a) Negotiation

The parties will make reasonable efforts to resolve any Dispute by amicable negotiations and will provide frank, candid and timely disclosure of all relevant facts, information and documents to facilitate negotiations.

(b) Mediation

If all or any portion of a Dispute cannot be resolved by good faith negotiations within 30 days, either party may by notice to the other party refer the matter to mediation. Within 7 days of delivery of the notice, the parties will mutually appoint a mediator. If the parties fail to agree on the appointment of the mediator, then either party may apply to the British Columbia International Commercial Arbitration Centre for appointment of a mediator. The parties will continue to negotiate in good faith to resolve the Dispute with the assistance of the mediator. The place of mediation will be Surrey, British Columbia. Each party will equally bear the costs of the mediator and other out-of-pocket costs, and each party will bear its own costs of participating in the mediation.

(c) Litigation

If within 90 days of the request for mediation the Dispute is not settled, or if the mediator advises that there is no reasonable possibility of the parties reaching a negotiated resolution, then either party may without further notice commence litigation.

15. JURISDICTION AND COUNCIL NON-APPROPRIATION

- 15.1 Nothing in this agreement limits or abrogates, or will be deemed to limit or abrogate, the jurisdiction of the Council of the City in the exercise of its powers, rights or obligations under any public or private statute, regulation or by-law or other enactment.
- 15.2 The Contractor recognizes and agrees that the City cannot make financial commitments beyond the City's current fiscal year. The City will annually make bonafide requests for appropriation of sufficient funds to cover all payments covered by this agreement. If City Council does not appropriate funds, or appropriates insufficient funds, the City will notify the Contractor of its intention to terminate or reduce the services so affected within 30 days after the non-appropriation becomes final. Such termination shall take effect 30 days from the date of notification, shall not constitute an event of default and shall relieve the City, its officers and employees, from any responsibility or liability for the payment of any further amounts under this agreement.

16. GENERAL

16.1 Entire Agreement

This agreement, including the Appendices and any other documents expressly referred to in this agreement as being a part of this agreement, contains the entire agreement of the parties regarding the provision of the Goods and Services and no understandings or agreements, oral or otherwise, exist between the parties except as expressly set out in this agreement. This agreement supersedes and cancels all previous agreements between the parties relating to the provision of the Goods and Services.

16.2 Amendment

This agreement may be amended only by agreement in writing, signed by both parties.

16.3 Contractor Terms Rejected

In the event that the Contractor issues an invoice, packing slip, sales receipt, or any like document to the City, the City accepts the document on the express condition that any terms and conditions in it which constitute terms and conditions which are in addition to or which establish conflicting terms and conditions to those set out in this agreement are expressly rejected by the City.

16.4 Survival of Obligations

All of the Contractor's obligations to perform the Goods and Services in a professional and proper manner will survive the termination or completion of this agreement.

16.5 Cumulative Remedies

The City's remedies under this agreement are cumulative and in addition to any right or remedy which may be available to the City at law or in equity.

16.6 Notices

Any notice, report or other document that either party may be required or may wish to give to the other should be in writing, unless otherwise provided for, and will be deemed to be validly given to and received by the addressee, if delivered personally, on the date of such personal delivery, if delivered by facsimile, on transmission, or if by mail, five calendar days after posting. The addresses for delivery will be as follows:

(a) The City:

City of Surrey, Surrey City Hall
 insert department/division/section name>
13450 – 104 Avenue, Surrey, B.C., Canada V3T 1V8

Attention: **insert contact name**>
 insert title>

Telephone No.: **insert**>
Fax No.: **insert**>
Email: **insert**>

(b) The Contractor:

 insert name and address>

Attention: **insert contact name**>
 insert title>

Business Fax No.: **insert**>
Business Email: **insert**>

16.7 Unenforceability

If any provision of this agreement is invalid or unenforceable, it will be severed from the agreement and will not affect the enforceability or validity of the remaining provisions of the agreement.

16.8 Headings

The headings in this agreement are inserted for convenience of reference only and will not form part of nor affect the interpretation of this agreement.

16.9 Singular, Plural and Gender

Wherever the singular, plural, masculine, feminine or neuter is used throughout this agreement the same will be construed as meaning the singular, plural, masculine, feminine, neuter or body corporate where the context so requires.

16.10 Waiver

No waiver by either party of any breach by the other party of any of its covenants, obligations and agreements will be a waiver of any subsequent breach or of any other covenant, obligation or agreement, nor will any forbearance to seek a remedy for any breach be a waiver of any rights and remedies with respect to such or any subsequent breach.

16.11 Signature

This agreement may be executed in one or more counterparts all of which when taken together will constitute one and the same agreement, and one or more of the counterparts may be delivered by fax or PDF email transmission.

16.12 Enurement

This agreement shall enure to the benefit of and be binding upon the respective successors and permitted assigns of the City and the Contractor.

SPECIAL CONDITION

16.13 Compliance with COVID 19 Policy

It is a material term of this agreement that the Contractor, and any personnel and subcontractors providing the Goods and performing the Services who (a) will enter City facilities or (b) will be in close physical proximity to City staff outdoors, comply with the City's COVID 19 policy(ies) and requirements, including with respect to Contractor's personnel will be fully vaccinated against COVID-19 and require their personnel to provide proof of vaccination status in a form acceptable to the City prior to beginning work each day on-site. The Contractor will immediately remove any personnel or subcontractors who do not meet, maintain or comply with any such polices and requirements.

The personal information collected will be held in confidence by the City and will be used only to monitor compliance with, and to administer, the City's vaccination policies. The City will collect this personal information under s. 26(c) of the *Freedom of Information and Protection of Privacy Act*.

IN WITNESS WHEREOF the parties hereto have executed this Agreement on the day and year first above written.

CITY OF SURREY

I/We have the authority to bind the City.

(Signature of Authorized Signatory)

(Print Name and Position of Authorized Signatory)

[INSERT NAME OF CONTRACTOR]

I/We have the authority to bind the Contractor.

(Legal Name of Contractor)

(Signature of Authorized Signatory)

(Signature of Authorized Signatory)

(Print Name and Position of Authorized Signatory)

(Print Name and Position of Authorized Signatory)

(APPENDICES 1 THROUGH 5 WILL BE INSERTED LATER WHEN AN AGREEMENT IS ASSEMBLED FOR EXECUTION INCLUDING INFORMATION FROM THE RFP AND SUCCESSFUL PROPOSAL)

APPENDIX 1 – SPECIFICATIONS OF GOODS AND SCOPE OF SERVICES

APPENDIX 1-A DRAWINGS

APPENDIX 1-B MAPS

APPENDIX 2 – FEES AND PAYMENT

APPENDIX 3 – TIME SCHEDULE

APPENDIX 4 – PERSONNEL AND SUB-CONTRACTORS

APPENDIX 5 – ADDITIONAL SERVICES

SCHEDULE C – FORM OF PROPOSAL

RFP Project Title: **Engineering Services for Inspection of Flood Box Construction**

RFP Reference No.: **1220-030-2023-001**

Legal Name of Proponent: _____

Contact Person and Title: _____

Business Address: _____

Business Telephone: _____

Business Fax: _____

Business E-Mail Address: _____

TO:

City of Surrey

City Representative: Sunny Kaila, Manager, Procurement Services

Email for PDF Files: purchasing@surrey.ca

Dear Sir:

1.0 I/We, the undersigned duly authorized representative of the Proponent, having received and carefully reviewed all of the Proposal documents, including the RFP and any issued addenda posted on the City Website and BC Bid Website, and having full knowledge of the Goods and Services required, and having fully informed ourselves as to the intent, difficulties, facilities and local conditions attendant to performing the Goods and Services, submit this Proposal in response to the RFP.

2.0 **I/We confirm** that the following schedules are attached to and form a part of this Proposal:

Schedule C-1 – Statement of Departures;
Schedule C-2 – Proponent’s Experience, Reputation and Resources;
Schedule C-3 – Proponent’s Technical Proposal (Goods and Services);
Schedule C-4 – Proponent’s Technical Proposal (Time Schedule); and
Schedule C-5 – Proponent’s Financial Proposal.

3.0 **I/We confirm** that this proposal is accurate and true to best of my/our knowledge.

4.0 I/We confirm that, if I/we am/are awarded the agreement, I/we will at all times be the “prime contractor” as provided by the Worker's Compensation Act (British Columbia) with respect to the Goods and Services. I/we further confirm that if I/we become aware that another contractor at the place(s) of the Goods and Services has been designated as the “prime contractor”, I/we will notify the City immediately, and I/we will indemnify and hold the City harmless against any claims, demands, losses, damages, costs, liabilities or expenses suffered by the City in connection with any failure to so notify the City.

This Proposal is submitted by this **[day]** day of **[month], [year]**.

I/We have the authority to bind the Proponent.

(Legal Name of Proponent)

(Signature of Authorized Signatory)

(Signature of Authorized Signatory)

(Print Name and Position of Authorized Signatory)

(Print Name and Position of Authorized Signatory)

SCHEDULE C-1 - STATEMENT OF DEPARTURES

1. I/We have reviewed the proposed agreement attached to the RFP as Schedule "B". If requested by the City, I/we would be prepared to enter into that agreement, amended by the following departures (list, if any):

Section	Requested Departure(s) / Alternative(s)
----------------	--

2. The City of Surrey requires that the successful Proponent have the following in place **before commencing the Services**:

- (a) Workers' Compensation Board coverage in good standing and further, if an "Owner Operator" is involved, personal operator protection (P.O.P.) will be provided,
Workers' Compensation Registration Number _____;
- (b) Prime Contractor qualified coordinator is Name: _____ and Contact Number: _____;
- (c) Insurance coverage for the amounts required in the proposed agreement as a minimum, naming the City as additional insured and generally in compliance with the City's sample insurance certificate form available on the City's Website at www.surrey.ca search [Standard Certificate of Insurance](#);
- (d) City of Surrey or Intermunicipal business license Number: _____;
- (e) If the Proponent's Goods and Services are subject to GST, the Proponent's GST Number is _____; and
- (f) If the Proponent is a company, the company name indicated above is registered with the Registrar of Companies in the Province of British Columbia, Canada, Incorporation Number _____.

As of the date of this Proposal, we advise that we have the ability to meet all of the above requirements **except as follows** (list, if any):

Section	Requested Departure(s) / Alternative(s)
----------------	--

3. I/We offer the following alternates to improve the Services described in the RFP (list, if any):

Section	Requested Departure(s) / Alternative(s)
----------------	--

4. The Proponent acknowledges that the departures it has requested in Sections 1, 2 and 3 of this Schedule C-1 will not form part of the agreement unless and until the City agrees to them in writing by initialling or otherwise specifically consenting in writing to be bound by any of them.

SCHEDULE C-2 - PROPONENT'S EXPERIENCE, REPUTATION AND RESOURCES

Proponents should provide information on the following (use the spaces provided and/or attach additional pages, if necessary):

- (i) Location of primary business, branch locations, background, stability, structure of the Proponent and number of years business has been operational.
- (ii) Proponent's relevant experience and qualifications in delivering Goods and Services similar to those required by the RFP.
- (iii) Proponent's demonstrated ability to provide the Goods and perform the Services.
- (iv) Proponent's equipment resources, capability and capacity, as relevant (including equipment resources under the Proponent's control, equipment resources to be rented, and equipment resources to be purchased).
- (v) Proponent's references (name and telephone number). The City's preference is to have a minimum of three references.
- (vi) Proponent's financial strength (with evidence such as financial statements, bank references).
- (vii) Proponents should provide information on the background and experience of all key personnel (Project Manager, Lead Designer, Contract Administrator, Inspector, etc.) proposed to undertake the Services (use the spaces provided and/or attach additional pages, if necessary). Attach individual resumes if available, to a maximum of three (3) pages.

Provide details (scope, client info, project reference number, year completed, location etc.) for three (3) projects with similar scope to this proposed project, completed by the team members.

Key Personnel

Name: _____

Experience:

Dates: _____

Project Name: _____

Responsibility: _____

Dates: _____

Project Name: _____

Responsibility: _____

Dates: _____
 Project Name: _____
 Responsibility: _____

Sub-Contractors

(viii) Proponents should provide the following information on the background and experience of all sub-contractors proposed to undertake a portion of the Goods and Services (use the spaces provided and/or attach additional pages, if necessary).

DESCRIPTION OF SERVICES	SUB-CONTRACTORS NAME	YEARS OF WORKING WITH PROPONENT	TELEPHONE NUMBER AND EMAIL

(ix) Describe any difficulties or challenges you might anticipate in providing the Goods and Services to the City and how you would plan to manage these.

[END OF PAGE]

SCHEDULE C-3 - PROPONENT'S TECHNICAL PROPOSAL (GOODS AND SERVICES)

Proponents should provide the following (use the spaces provided and/or attach additional pages, if necessary):

- (i) a narrative that illustrates an understanding of the City's requirements for the Goods and Services;
- (ii) a description of the general approach and methodology that the Proponent would take in providing the Goods and performing and managing the Services including specifications and requirements;
- (iii) a narrative that illustrates how the Proponent will perform the Services as specified in Schedule A, Section 3. Project Management and General Instructions, and accomplish required objectives within the City's schedule;
- (iv) a description of the standards to be met by the Proponent in the performance of the Services;
- (v) a list of reports that you would anticipate providing the City's management team, including their relationship to project milestones and the method of delivery (electronic, paper, e-mail, other);
- (vi) Work Plan: Provide a detailed plan of approach including the description of the Services proposed and the level of detail to be included in the project task in meeting the City's objectives and requirements. The Proponent's work plan should make reference to the requirements as appropriate;
- (vii) Implementation Plan: If successful, the Proponent should:
 - (1) describe the approach to developing and implementing a smooth transition plan;
 - (2) provide a detailed description of implementation and monitoring procedures that the Proponent will use to ensure that key personnel are performing to the standards expected; and
 - (3) describe what the Proponent's management tools will be used to control project costs.
- (vi) Environmental and Social Responsibility: Describe your commitment to environmental stewardship initiatives, recycling practices and carbon footprint reduction; and
- (vii) Value Added Services: The Proponent should provide a description of value added, innovative ideas and unique services that the Proponent can offer to implement the City's requirements relevant to the scope of Services described in this RFP. Unless otherwise stated, it is understood that there are no extra costs for these goods and services.

SCHEDULE C-4 - PROPONENT'S TECHNICAL PROPOSAL (TIME SCHEDULE)

The City encourages responses that demonstrate a thorough understanding of the nature of the work and what the Proponent must do to get the work done properly. To this end, Proponents should provide an estimated project schedule, with major item descriptions and time indicating a commitment to provide the Goods and perform the Services within the time specified (use the spaces provided and/or attach additional pages, if necessary).

MILESTONE DATES _____

ITEM DESCRIPTION	SCHEDULE IN									
	1	2	3	4	5	6	7	8	9	10

SAMPLE

[END OF PAGE]

SCHEDULE C-5 - PROPONENT'S FINANCIAL PROPOSAL

The Proposal shall indicate a clearly defined fee structure with man hours identified per task and per team member. For Proposals that have multiple projects, the Contractor will provide in their Proposal a project funding distribution table allocating the Contractor's total fee (inclusive of disbursements and sub-contractor's fees, (not including GST) for each project defined in Section 2 of Schedule A. The hourly rates shall remain fixed for a period of two (2) calendar years following acceptance/award of the contract.

The Contractor should include copies of all sub-contractor's proposals as part of their response to this Schedule C-5.

Indicate the Proponent's proposed fee (excluding GST), and the basis of calculation (use the spaces provided and/or attach additional pages, if necessary) as follows (as applicable):

Schedule of Rates:

Item #	Item Name	Total Amount
To provide all labour, materials, plant and equipment and all other services necessary for the provision of a [insert project title] as stated in the specifications and drawings, at [insert project location – address] .		
1.	General: Project Management / permitting / insurance	\$
2.	Mobilization / demobilization / delivery	\$
3.	Enclosure cost	\$
4.	Boilers cost	\$
5.	Pumps cost	\$
6.	Piping / supports / insulation / piping accessories	\$
7.	Electrical / controls / programming	\$
8.		\$
Note #1: Overheads, General Conditions and Profit are to be included in the above amounts.		
Note #2: B.C. Provincial Sales Tax is included where applicable.		
		Subtotal:
		\$
		GST (5%):
		\$
CURRENCY: Canadian	TOTAL PROPOSAL PRICE:	\$

SAMPLE

List of Optional Prices:

The following is a list of optional price(s) and forms part of this RFP, upon the acceptance of any or all of the optional price(s). The optional prices are an addition or a deduction to the Total Proposal Price and do not include GST. DO NOT state a revised Total Proposal Price.

Item #	Item Name	Addition	Deduction
OP.1	Optional Controls - Refer to Specific Note 2 in drawing # (C01-P03)	\$	\$
OP.2	Extended one (1) year Warranty for the CBP	\$	\$
OP.3	Extended two (2) years Warranty for the CBP	\$	\$
OP.4	Annual Operation & Maintenance (excluding utility billing for water, electricity and natural gas)	\$	\$
OP.5	Deleting emergency propane connection	\$	\$
		\$	\$

Proponents should complete the following tables setting out the all-inclusive hourly rates including overhead, profit, small tools and work vehicles (trucks/vans) for approved extras/credits for all applicable categories of labour (use the spaces provided and/or attach additional pages, if necessary):

Table 1 – Schedule of Labour Rates:

Labour Category	Straight Time/hr (Plus GST)	Overtime Rate/hr (Plus GST)
.1 Superintendent	\$	\$
.2 Foreman	\$	\$
.3 Journeyman	\$	\$
.4 Apprentice	\$	\$
.5 Skilled Labourer	\$	\$
.6	\$	\$

Table 2 – Schedule of Equipment Rates:

No.	Equipment Description	Hourly Rate
		\$
		\$

Additional Expenses:

The proposed Contract attached as Schedule “B” to the RFP provides that expenses are to be included within the fee, other than the expenses listed in the Contract as disbursements. Details of disbursements are to be shown in the chart above. Please indicate any expenses that would be payable in addition to the proposed fee and proposed disbursements set out above:

Payment Terms:

A cash discount of _____% will be allowed if account is paid within _____ days, or the _____ day of the month following, or net 30 days, on a best effort basis.

[END OF PAGE]