



## **REQUEST FOR QUOTATIONS**

**Title:** South Surrey Indoor Arena Parking Lot Rehabilitation  
**Reference No.:** 1220-040-2022-025

## **MINOR WORKS**

(Construction Services)  
Issue Date: April 19, 2022

# REQUEST FOR QUOTATIONS

## TABLE OF CONTENTS

1. INTRODUCTION.....	3
2. ADDRESS FOR DELIVERY.....	3
3. DATE .....	3
4. INQUIRIES.....	3
5. ADDENDA .....	4
6. NO CONTRACT .....	4
7. ACCEPTANCE.....	4
8. CONTRACTOR'S EXPENSES.....	4
9. CONTRACTOR'S QUALIFICATIONS .....	4
10. CONFLICT OF INTEREST .....	4
11. SOLICITATION OF COUNCIL MEMBERS, CITY STAFF AND CITY CONSULTANTS.....	5
12. CONFIDENTIALITY .....	5
13. SIGNATURE .....	5
14. INFORMATION MEETING .....	5
Schedule A – Scope of Work and Drawings.....	7
Schedule B – Sample Contract .....	9
Schedule B – Appendix 1 Special Provisions .....	30
Schedule B – Appendix 2 Supplementary Specifications (Project).....	38
Schedule B – Appendix 2-A Contract Drawings .....	41
Schedule B – Appendix 3 Schedule of Quantities and Prices .....	42
Schedule B – Appendix 4 Construction Schedule.....	42
Schedule B – Appendix 5 Key Personnel, Subcontractors and Material Suppliers.....	42
Schedule B – Appendix 6 Prime Contractor Designation .....	42
Schedule B – Appendix 7 Contractor Health & Safety Expectations (Responsibility of Contractor(s)) .....	42
Schedule C – Form of Quotation.....	43
Attachments:	
1. City of Surrey, Project Completion Deliverables Worksheet .....	51
2. Prime Contractor Designation – Letter of Understanding.....	53
3. Contractor Health & Safety Expectations (Responsibility of Contractor(s)).....	54
4. Covid-19 Pre-Work Contractor Orientation Checklist.....	58

## REQUEST FOR QUOTATIONS

### 1. INTRODUCTION

The City of Surrey (the “**City**”) invites contractors to provide a quotation on the form attached as Schedule C (the “**Quotation**”) for the supply of the goods (if any) and services described in Schedule A (the “**Work**”). The description of the Work sets out the minimum requirements of the City. A person that submits a Quotation (the “**Contractor**”) should prepare a Quotation that meets the minimum requirements, and may as it may choose, in addition, also include goods, services or terms that exceed the minimum requirements.

### 2. ADDRESS FOR DELIVERY

The Contractor should submit the Quotation **electronically** in a single pdf file which must be delivered by email at: [purchasing@surrey.ca](mailto:purchasing@surrey.ca)

Confirmation of receipt of emails will be issued. Quotations that cannot be opened or viewed may be rejected. A Contractor bears all risk that the City’s receiving computer equipment functions properly so that City receives the Quotation.

**Note:** The maximum file size the City can receive is 10Mb. If sending large email attachments, Contractors should phone [604-590-7274] to confirm receipt.

### 3. DATE

The City would prefer to receive Quotations on or before May 6, 2022 (the “**Date**”).

### 4. INQUIRIES

All inquiries related to this Request for Quotations (“RFQ”) should be directed in writing to the person named below (the “**City Representative**”). Information obtained from any person or source other than the City Representative may not be relied upon

Name: Sunny Kaila, Manager, Procurement Services

Email: [purchasing@surrey.ca](mailto:purchasing@surrey.ca)

Reference #: 1220-040-2022-025.

Inquiries should be made no later than seven (7) business days before Date. The City reserves the right not to respond to inquiries made within seven (7) business days of the Date. Inquiries and responses will be recorded and may be distributed to all Contractors at the discretion of the City.

Contractors finding discrepancies or omissions in the Contract or RFQ or having doubts as to the meaning or intent of any provision, should immediately notify the City Representative. If the City determines that an amendment is required to this RFQ, the City Representative will issue an addendum in accordance with Section 5. No oral conversation will affect or modify the terms of this RFQ or may be relied upon by any Contractor.

## **5. ADDENDA**

If the City determines that an amendment is required to this RFQ, the City Representative will issue a written addendum by posting it on the BC Bid website at [www.bcbid.gov.bc.ca](http://www.bcbid.gov.bc.ca) and the City website at [www.surrey.ca](http://www.surrey.ca) (collectively, the “Websites”), and upon posting, any addenda will form a part of this RFQ. It is the responsibility of Contractors to check the Websites for addenda. The only way this RFQ may be added to, or amended in any way, is by a formal written addendum. No other communication, whether written or oral, from any person will affect or modify the terms of this RFQ or may be relied upon by any Contractor. By delivery of a Quotation the Contractor is deemed to have received, accepted and understood the entire RFQ, including any and all addenda.

## **6. NO CONTRACT**

This RFQ is simply an invitation for quotations (including prices and terms) for the convenience of all parties. It is not a tender and no obligations of any kind will arise from this RFQ or the submission of Quotations. The City may negotiate changes to any terms of a Quotation, including terms in Schedules A and B and including prices, and may negotiate with one or more Contractors or may at any time invite or permit the submission of quotations (including prices and terms) from other parties who have not submitted Quotations.

## **7. ACCEPTANCE**

A Quotation will be an offer to the City which the City may accept at any time by signing the copy of the Quotation and delivering it to the Contractor. A Quotation is not accepted by the City unless and until both the authorized signatory of the Contractor and the authorized signatory of the City have signed. Delivery of the signed Contract by the City may be by fax, pdf e-mail or hard copy. In that event, the contract will be comprised of the documents included in the definition of Contract in Schedule B.

## **8. CONTRACTOR'S EXPENSES**

Contractors are solely responsible for their own expenses in preparing and submitting Quotations, and for any meetings, negotiations or discussions with the City or its representatives and consultants, relating to or arising from the RFQ. The City will not be liable to any Contractor for any claims, whether for costs, expenses, losses or damages, or loss of anticipated profits, incurred by the Contractor in preparing and submitting a Quotation, or participating in negotiations for a contract, or other activity related to or arising out of this RFQ.

## **9. CONTRACTOR'S QUALIFICATIONS**

By submitting a Quotation, a Contractor represents that it has the expertise, qualifications, resources, and relevant experience with the requirements of the Work.

## **10. CONFLICT OF INTEREST**

A Contractor should disclose in its Quotation any actual or potential conflicts of interest and existing business relationships it may have with the City, its elected or appointed officials or employees. The City may rely on such disclosure.

## 11. SOLICITATION OF COUNCIL MEMBERS, CITY STAFF AND CITY CONSULTANTS

Contractors and their agents will not contact any member of the City Council, City staff or City consultants with respect to this RFQ, other than the City Representative named in section 4, at any time prior to the award of a contract or the cancellation of this RFQ and which could be viewed as one Contractor attempting to seek an unfair advantage over other Contractors.

## 12. CONFIDENTIALITY

All Quotations become the property of the City and will not be returned to the Contractor. All Quotations will be held in confidence by the City unless otherwise required by law. Contractors should be aware the City is a "public body" defined by and subject to the *Freedom of Information and Protection of Privacy Act* of British Columbia.

## 13. SIGNATURE

The legal name of the person or firm submitting the Quotation should be inserted in the Quotation. The Quotation should be signed by a person authorized to sign on behalf of the Contractor and include the following:

- (a) If the Contractor is a corporation then the full name of the corporation should be included, together with the names of authorized signatories. The Quotation should be executed by all of the authorized signatories or by one or more of them provided that a copy of the corporate resolution authorizing those persons to execute the Quotation on behalf of the corporation is submitted;
- (b) If the Contractor is a partnership or joint venture then the name of the partnership or joint venture and the name of each partner or joint venturer should be included, and each partner or joint venturer should sign personally (or, if one or more person(s) have signing authority for the partnership or joint venture, the partnership or joint venture should provide evidence to the satisfaction of the City that the person(s) signing have signing authority for the partnership or joint venture). If a partner or joint venturer is a corporation then such corporation should sign as indicated in subsection (a) above; or
- (c) If the Contractor is an individual, including a sole proprietorship, the name of the individual should be included.

## 14. INFORMATION MEETING

An information meeting will be hosted by the City Representative to discuss the City's requirements under this RFQ (the "**Information Meeting**"). While attendance is at the discretion of Contractors, Contractors who do not attend will be deemed to have attended the Information Meeting and to have received all of the information given at the Information Meeting.

At the time of issuance of this RFQ a meeting has been scheduled as follows:

Date: **Tuesday, April 26, 2022**

Time: 10:30 AM

Location: South Surrey Arena, 2199 148 Street, Surrey, BC

**Note: Each person attending the Information Meeting is required to complete a Covid-19 Prework Contractor Orientation Checklist (see Attachment 4). Please send the completed checklist on or before April 26, 2022, to [purchasing@surrey.ca](mailto:purchasing@surrey.ca).**

It is possible that some questions raised, and information provided during the Information Meeting may be the only source of critical information essential to prepare and submit a successful Quotation. Contractors are responsible to ensure they are fully informed and have a clear understanding of the requirements.

Contractors are to examine the site prior to submitting a Quotation to fully acquaint themselves with all existing conditions reasonably inferable from examination of the site and its surroundings and the RFQ and to make allowance for such conditions in the Quotation. By submitting a Quotation, a Contractor represents that it has examined the site fully as to all conditions, contingencies, risks and circumstances, local or otherwise, which might influence or affect the performance of the Work.

**Note: No minutes of the information meeting and site tour will be provided**

The Contractor is responsible for parking fees, if applicable.

## SCHEDULE A – SCOPE OF WORK

**PROJECT TITLE: South Surrey Indoor Arena Parking Lot Rehabilitation**

**PROJECT No.: 1220-040-2022-025**

### 1. DESCRIPTION OF SCOPE OF WORK

The *Contractor* shall furnish all necessary labour, supervision, materials, plant, equipment, layout, survey, permits, and inspections, and related services to pavement rehabilitation as noted in the *Contract Drawings*. Furnish certificates confirming work conforms to requirements of Authorities having jurisdiction.

The general components of *Work* includes, but is not limited to: Complete rehabilitation or replacement of pavement in two phases, including line painting and new curbs as indicated; and erosion and sediment control plan.

The *Work* will be undertaken at the *Place of the Work*, as follows:

2199 – 148 Street, Surrey, BC V4A 8L5.

The detailed scope of *Work* is as described in the Special Provisions (Schedule B – Appendix 1), Supplementary Specifications (Project) (Schedule B- Appendix 2), and Contract Drawings (listed below) (Schedule B – Appendix 2A).

Where a project specification does not exist, the default project specification shall adhere to MMCD specifications (excluding measurement and payment descriptions). The City has project specifications to MMCD which is included herein. These project specifications shall take precedence over the basic MMCD specifications.

The lack of and/or omission of detailed specifications does not minimize the acceptable levels of service and only the best commercial practices are acceptable.

Contractor to comply with all BC Plumbing Code, BC Fire Marshal, BC Workers' Compensation Board, National Building Code of Canada, BC Boiler Inspector, BC Electrical Inspector, National Fire Protection Association, and any other authorities having local jurisdiction. Failure to abide by these rules and regulations will result in being immediately escorted from the work site.

## 2. LIST OF CONTRACT DRAWINGS

The following Contract Drawings are included as part of this RFQ.

<b>Schedule 2: List of <i>Contract Drawings</i></b>				
<b>DESCRIPTION</b>	<b>DRAWING No.</b>	<b>DATE</b>	<b>REVISION No.</b>	<b>REVISION DATE</b>
<b>SOUTH SURREY ARENA PARKING LOT REHABILITATION</b>				
Cover, Drawing Index	21-0714-C1	2021-08-13	2	2022-03-08
General Notes	21-0714-N1	2021-08-13	2	2022-03-08
Site Grading	21-0714-G1	2021-08-13	2	2022-03-08
Pavement Marking	21-0714-PM1	2021-08-13	2	2022-03-08
Erosion and Sediment Control Plan Stage 1	21-0714-ESC1	2021-08-13	3	2022-03-08
Erosion and Sediment Control Plan Stage 2	21-0714-ESC1	2021-08-13	3	2022-03-08
Erosion and Sediment Control Plan Stage 3	21-0714-ESC1	2021-08-13	3	2022-03-08

- END OF PAGE -



**SCHEDULE B  
SAMPLE – CONSTRUCTION CONTRACT**

**Title: South Surrey Indoor Arena Parking Lot Rehabilitation**

Contract No.: 1220-040-2022-025

**THIS AGREEMENT** dated the \_\_\_\_\_ day of \_\_\_\_\_, 202\_.

**BETWEEN:**

**CITY OF SURREY**  
13450 – 104<sup>th</sup> Avenue  
Surrey, B.C., V3T 1V8, Canada

(the "**City**")

**OF THE FIRST PART**

**AND:**

\_\_\_\_\_  
\_\_\_\_\_  
\_\_\_\_\_

(Full legal name and address of Contractor)

(the "**Contractor**")

**OF THE SECOND PART**

**WHEREAS** the Contractor wishes to undertake the following project for the benefit of the City:

*South Surrey Indoor Arena Parking Lot Rehabilitation*

**NOW THEREFORE THIS CONTRACT WITNESSETH** that in consideration of the premises and payment of One (\$1.00) Dollar and other good and valuable consideration paid by each of the parties to each other (the receipt and sufficiency of which each party hereby acknowledges), the parties hereby covenant and agree with each other as follows:

**1. DEFINITIONS**

1.1 For the purposes of this Contract, the following terms shall have the meanings set forth below:

- (a) "**Certification of Completion**" means a certificate issued indicating that Substantial Performance of the Work has been achieved;
- (b) "**Certificate of Total Performance**" means a certificate issued indicating that the Work has been achieved;

- (c) **“Change”** means an addition to, deletion from or alteration of the Work;
- (d) **“Change Order”** means a Change is approved, the Consultant shall issue a written approval, setting out a description of the Work covered by the Change, the price or method of valuation for the Work, the change in the Contract Price and adjustment, if any, to the Contract Time. The value of the Work performed in a Change shall be included for payment with the certificates for payment;
- (e) **“City”** means the City of Surrey;
- (f) **“Consultant”** is the person or entity engaged by the City and identified as such in the Contract. The Consultant is the Architect, the Engineer or entity licensed to practice in the province of British Columbia. The term Consultant means the Consultant or the Consultant’s authorized representative;
- (g) **“Construction Schedule”** means a construction schedule indicating the planned start and completion dates of the major activities of the Work as set out in Appendix [ ], a future Appendix;
- (h) **“Contract”** means this Contract as set out and described in the Contract Documents;
- (i) **“Contract Administrator”** means the person, firm or corporation appointed by the City and identified by the City in writing to the Contractor. The Contract Administrator may be the City’s Engineer, other employee, or officer, or may be an outside consultant;
- (j) **“Contract Documents”** means this Contract including all schedules and appendices, construction standards, specifications and drawings;
- (k) **“Contract Drawings”** means the graphic and pictorial portions of the Contract Documents, wherever located and whenever issued, showing the design, location and dimensions of the Work, generally including plans, elevations, sections, details and diagrams;
- (l) **“Contract Price”** means the price of the Work as set out Section 4.1 of this Contract;
- (m) **“Contract Time”** means the period of time for the completion of the Work as provided by the Contract Documents;
- (n) **“Contractor”** means the person, firm or corporation identified as such in this Contract and includes the Contractor’s authorized representative as designated to the City in writing;
- (o) **“Extra Work”** has the meaning set out in Section 33;
- (p) **“Milestone Date”** means any date specified in the Contract Documents for completion of the Work, or portion of the Work, including the dates of Substantial Performance or Total Performance;

- (q) **“Overhead”** means all costs associated with management, supervision, insurance, as-built preparation and warranty, administration and supervision at the Place of Work (including the provision of and maintaining office coordination, office costs, supervision, site trailer, telephone service, and long-distance charges) courier, permits, insurance and small tools and general office supplies as required for the performance of the Work.”
- (r) **“Payment Certifier”** is the person or entity identified as such in the Contract responsible for the issuance of certificates of payment;
- (s) **“Place of Work”** means the designated site or location where the Work products are to be finally or permanently constructed or installed;
- (t) **“Project Manager”** is the person or entity engaged by the City and identified as such in the Contract;
- (u) **“Substantial Performance”** means the stage of completion when:
  - (a) all Work, as certified by the Contract Administrator, is capable of completion or correction at a cost of not more than:
    - (i) 3% of the first \$500,000 of the Contract Price;
    - (ii) 2% of the next \$500,000 of the Contract price; and
    - (iii) 1% of the balance of the Contract Price, and
  - (b) the Work, or a substantial part of it, is ready for use or is being used for the purpose intended.
- (v) **“Total Performance”** means when all Work, including all deficiencies but excluding any correction of completed Work that appears during the on-going warranty or guarantee obligations as provided in the Contract Documents, as certified by the Contract Administrator; and
- (w) **“Work”** means and includes anything and everything required to be done for the fulfillment and completion of this Contract.

## 2. THE WORK – START/COMPLETION DATES

- 2.1 The Contractor will perform all Work and provide all labour, equipment and material and do all things strictly as required by the Contract Documents.

### 2.1.1 PANDEMIC RESTRICTIONS

The parties acknowledge that this Agreement has been entered into during the on-going COVID-19 pandemic (the “Pandemic”). The Contractor advises that it is able to proceed with the Services under the Pandemic conditions and restrictions (collectively the “Pandemic Restrictions”) as they exist as of the date of this Agreement. The parties acknowledge that Pandemic Conditions may change so as to cause unavoidable interruptions or interference to the Contractor’s performance of the Services. The parties confirm:

- (a) notwithstanding the known existence of the Pandemic, Section 2.1.1 will apply to new Pandemic Restrictions, which arise after the date of this Agreement, whether

anticipated or not, which reasonably interfere with the Contractor's performance of the Services, such that upon the Contractor giving required notice shall be entitled to an extension of the time to perform the Services, but shall not be entitled to reimbursement of any costs;

- (b) notwithstanding any such new Pandemic Restrictions, the Agreement will remain valid and in force, subject to the terms of the Agreement including, without limitation Section 23 (Workers' Compensation Board and Occupational Health and Safety); and
- (c) if new Pandemic Restrictions occur that cause or threaten interruption of the Services the Contractor will give the City immediate notice, and a written plan of the interim steps the Contractor will take, if any, during the interruption of the Services, and when Pandemic Restrictions permit, provide the City with a written plan for the resumption of the Services.

2.2 The Contractor will commence the Work in accordance with the Notice to Proceed. The Contractor will proceed with the Work diligently, will perform the Work generally in accordance with the Construction Schedules as required by the Contract Documents and will achieve Substantial Performance of the Work on or before July 31, 2022 from the Notice to Proceed date subject to the provision of the Contract Documents for adjustments to the Contract Time.

2.3 Time shall be of the essence of the Contract.

### **3. CONTRACT DOCUMENTS**

3.1 All of the Contract Documents shall constitute the entire Contract between the City and the Contractor.

3.2 The Contract supersedes all prior negotiations, representations or agreements, whether written or oral, and the Contract may be amended only in strict accordance with the provisions of the Contract Documents.

3.3 If there is any inconsistency or conflict between the provisions of the Contract Documents, then the Contract Documents shall govern and take precedence in the following order with this Contract taking precedence over all other Contract Documents:

- (a) Contract;
- (b) Addenda (if any);
- (c) Departmental Construction Standards (if any);
- (d) Specifications;
- (e) Drawings; and
- (f) all other Contract Documents.

### **4. CONTRACT PRICE**

4.1 The Contract Price for the Work shall be the sum of \_\_\_\_\_ Dollars and \_\_\_\_\_ Cents (\$ \_\_\_\_\_), plus goods and services tax in the amount of \_\_\_\_\_ Dollars and \_\_\_\_\_ Cents (\$ \_\_\_\_\_), for a total Contract Price of \_\_\_\_\_ Dollars and \_\_\_\_\_ Cents (\$ \_\_\_\_\_) in Canadian funds (the

"Contract Price") plus any adjustments approved by the City, including any payments owing on account of Change Orders and agreed to Extra Work, approved in accordance with the provisions of the Contract Documents.

- 4.2 For greater certainty, the Contract Price shall be the entire compensation owing to the Contractor for the Work and this compensation shall cover and include all profit and all costs of supervision, labour, material, equipment, Overhead, financing, and all other costs and expenses whatsoever incurred in performing the Work, even if the Contract Documents does not specifically mention such items. The Contract Price is a firm fixed price.

## 5. HOLDBACKS

- 5.1 The City shall hold back 10%, or other percentage as required by the *Builders Lien Act*, SBC 1997, c. 45, as amended (the "*Builders Lien Act*"), of any amounts due to the Contractor as a builders lien holdback.
- 5.2 In addition to other holdbacks as provided by the Contract Documents, when considering Substantial Performance, the City may hold back from payments otherwise due to the Contractor 200% of a reasonable estimate, as determined by the City's Representative, on account of deficient or Defective Work already paid for. This holdback may be held, without interest, until such deficiency or defect is remedied. The items of defect or deficiency and the amounts of related holdback shall be listed separately on the invoice.
- 5.3 If after Substantial Performance is achieved the Contractor is unable to complete any of the Work because of climatic or other conditions beyond the Contractor's reasonable control, then the City may hold back from payments otherwise due to the Contractor the amount as estimated by the Consultant in consultation with the Contractor by which the cost to have others complete the Work exceeds the estimated Contract Price for such Work.
- 5.4 The City may, in addition to other holdbacks as provided by the Contract Documents, hold back an amount equal to any lien which has been filed with respect to the Work, plus 15% as security for costs. The City may, at its option, after five (5) days written notice to the Contractor, pay such amount into court to discharge the lien. If the lien is discharged without payment of the holdback into court, then the City shall pay such holdback to the Contractor, without interest.
- 5.5 **Holdback period of 55 days will follow the date of substantial performance.** The City will perform a court registry search on the 46th day, on a best effort basis.

## 6. INVOICING AND PAYMENT

- 6.1 Subject to applicable legislation, including without limitation the holdbacks referred to in above, and the provisions of the Contract Documents, the City shall make payments to the Contractor thirty (30) days after receipt of any invoice from the Contractor.
- 6.2 The Contractor shall submit invoice(s) for payment to the City, based on the completion of each phase of the Work. Any and all Extra Work as approved by the City, should be clearly identified and quantified on a separate invoice(s).
- 6.3 The invoice(s) submitted for the completion of each project phase shall be clearly itemized to the details of the phase completed or the amount of Work performed, the billing rates,

show an invoice number, contractor's name, address, telephone number, reference the City's purchase order number or name and location of employee, and in an itemized manner the amount due for each phase completed, tax (if any) and a grand total. The grand total will be subject to holdbacks.

- 6.4 The payment by the City of any monthly or other payment shall not bind the City with respect to any subsequent payment or the final progress payment, but shall be taken as approximate only, and shall not mean, or be construed to mean, that the City has accepted Work that is not in accordance with the requirements of the Contract Documents, or that the Contractor is in any manner released from its obligation to comply with the Contract Documents.
- 6.5 For earlier payment, the Contractor can offer a cash discount.
- 6.6 Payments to Contractors can be made through Electronic Funds Transfer (EFT), directly into the Contractor's bank account. An EFT application form can be provided to the successful Contractor for completion.

Invoices should be sent electronically to: [surreyinvoices@surrey.ca](mailto:surreyinvoices@surrey.ca)

- 6.7 The City shall not be liable for interest or overdue charges on any invoice.
- 6.8 Unless otherwise provided, all dollar amounts referred to in this Contract are in lawful money of Canada.
- 6.9 If the Contractor is a non-resident of Canada and does not provide to the City a waiver of regulation letter, the City will withhold and remit to the appropriate governmental authority the greater of:
- (a) 15% of each payment due to the Contractor; or
  - (b) the amount required under applicable tax legislation.

## **7. PERFORMANCE OF THE WORK**

- 7.1 The Contractor will perform and provide all labour, services and other acts, and provide all equipment, machinery, water, heat, power, and facilities required for performance of the Work.
- 7.2 The Contractor will not proceed with any work that is not part of the Work, except in accordance with the Contract.
- 7.3 The Contractor will apply for and pay for all necessary permits and licenses and pay all fees required for the performance of the Work.

## **8. CHANGES**

- 8.1 The City may, without invalidating the Contract, change the Work by adding to or deducting from the Work in which event the Construction Schedule will be adjusted.
- 8.2 The Contractor will not proceed with any Change without a written Change Order signed by the City.

- 8.3 The Contractor's Overhead and profit will not be allowed on Change Orders paid for from allowances specified in the Contract.
- 8.4 The value of a change in the Work shall be determined by one or more of the following methods:
- (a) by estimate and acceptance in a lump sum; or
  - (b) by unit prices as set out in the Contract, or subsequently agreed upon; or
  - (c) by actual cost and an allowance for Overhead and profit as follows:
    - 1. Contractor's Overhead and profit on expenditures from cash allowances, shall be included in the Contract Price, except the Contractor is entitled to additional Overhead and profit only on the portion of the change greater than the cash allowance. If the change is less than the cash allowance the Contract Price shall be decreased by the amount of the change without adjustment for the Contractor's Overhead and profit;
    - 2. for changes in the Work not covered by cash allowances:
      - (i) if there is no increase or decrease in the Contract Price the Contractor is not entitled to any Overhead and profit on the change,
      - (ii) if the Contract Price is increased, the Contractor is entitled to an additional:
        - .1 10% Overhead and profit on Work performed directly by the Contractor, and
        - .2 5% on Work performed by the Subcontractor, only on the portion of the increase in the Contract Price, and
        - .3 0% on design services and work performed by the Contractor's consultants;
      - (iii) if the Contract Price is decreased by the change the Contractor is not entitled to Overhead and profit on the reduction in the Contract Price;
    - 3. the Subcontractor or the sub-subcontractor Overhead and profit shall be 5% of the actual cost of all Subcontractor's or sub-subcontractor's changes in the Work; and
    - 4. where the change involves the substitution of one type of Work and/or Product for another the actual cost of the change, shall be the net difference in the actual cost without any entitlement to Overhead and profit."

## **9. SITE CONDITIONS**

- 9.1 The Contractor acknowledges and agrees that:
- (a) it has had the opportunity to undertake additional examinations or subsurface investigations, or both, of the Place of Work, including any buildings or structures involved with the Work, in order to satisfy itself as to site conditions, including subsurface conditions and the impact they could have on the Work and the Contract; and
  - (b) it is not entitled to any adjustment in the Contract, or to any other remuneration or damages whatsoever, in any way connected with the site conditions at the Place of Work, including subsurface conditions.

## **10. DOCUMENTS**

- 10.1 The Contractor will keep one copy of the Contract, including the schedules and all Drawings, specifications and shop drawings, at the Place of Work in good order and available for review by the City's Representative, and deliver a complete set to the City upon Substantial Performance of the Work.



10.2 The Contractor agrees that the City is hereby granted an unconditional and irrevocable perpetual license to reproduce and use, in whole or in part, and for any purpose or other project or work the City desires, all matters contained in or set out in the Contract including all drawings and specifications and all models furnished by the Contractor, and the Contractor agrees that the license granted by this section comprises the copyright, industrial design, trademark and all other intellectual property therein.

## **11. TIME**

11.1 The Contractor will proceed diligently and complete the Work in a good and workmanlike manner and strictly in accordance with the Construction Schedule.

11.2 If the Contractor is delayed in the performance of the Work by any act or neglect of the City, the Construction Schedule will be extended for such time as may be agreed by the City and the Contractor, acting reasonably.

11.3 The Contractor will, as required by the City, provide or up-date the Construction Schedule, showing the anticipated start and completion dates and durations of the major elements of the Work. Failure or refusal to provide a Construction Schedule or up-date will be a default.

11.4 Time is of the essence of the Contract.

## **12. TAXES AND DUTIES**

12.1 The Contractor will pay all taxes, custom duties and other charges relating to the Work, and the supply and installation of all materials and equipment included in the Work.

12.2 Where an exemption of taxes, custom duties or other charges is applicable to the Contract by way of the Contractor filing claims for, or cooperating fully with the City and the proper authorities in seeking to obtain such refunds, the Contractor will make such applications and provide such cooperation. Refunds that are properly due to the City and have been recovered by the Contractor will be promptly refunded to the City.

## **13. BUILDER'S LIENS**

13.1 The Contractor will immediately take steps to keep the Place of Work free of any builder's liens and certificates of pending litigation and the Contractor will defend and indemnify the City from any builder's lien or certificate of pending litigation filed as a result of the Work. The Contractor will pay all costs and expenses including actual legal costs incurred by the City as a result of any builder's lien or certificate of pending litigation related to the Work.

## **14. CITY DIRECTIONS**

14.1 The Contractor will in all respects complete the Work in accordance with the City's requirements and standards and to the satisfaction of the City.

14.2 The City's Representative may at any time and from time to time inspect the Work.

14.3 The Contractor will comply with all directions from the City relating to the coordination of the Work with the activities of the City or with other contractors hired by the City, should there be any.



14.4 The Contractor will have total control of the Work and will be solely responsible for ensuring the Work is in accordance with the requirements of the Contract.

**15. INSPECTIONS**

15.1 The Contractor will retain one or more independent contractors with the relevant professional education, skill and experience, to carry out and report upon all testing and other inspection activities necessary to confirm the Work is in accordance with the requirements of the Contract. The Contractor will promptly provide copies of such reports to the City's Representative.

15.2 If Work is designated for tests, inspections or approvals by authorized agencies, the Contractor will give the City's Representative reasonable notice of when the Work will be ready for review and inspection.

**16. USE OF PLACE OF WORK**

16.1 The Contractor will confine its tools, machinery, equipment and materials to limits as may be established by the City's Representative, acting reasonably.

16.2 The Contractor will maintain the Place of Work in a tidy condition and free from the accumulation of waste products and debris, other than that caused by the City, other contractors or their employees.

16.3 Prior to application for the Certificate of Total Performance, the Contractor will remove all surplus products, tools, machinery and equipment, and any waste and debris, and leave the Place of Work clean and suitable for occupancy by the City.

16.4 The Contractor will not have exclusive use of the Place of Work, and will undertake the Work in cooperation with the City, and other users of the Place of Work as the City may permit or direct.

16.5 The Contractor will protect the property adjacent to the Place of Work from damage and will hold the City harmless from any claims which may arise as a result of the Contractor's operations under the Contract, or from failure to provide such protection, or both.

16.6 The Contractor will protect the Work, the Place of Work, the City's property from damage and will be responsible for any damage which may arise as a result of operations under the Contract, except damage which occurs as a result of actions of the City.

16.7 Should any damage occur to the Work, the Place of Work, or the City's property, or all of the aforementioned, for which the Contractor is responsible, the Contractor will:

- (a) make good such damage to the Work, and
- (b) if the City so directs, make good such damage to the City's property,

and the Construction Schedule will be extended for such time as may be agreed by the City and the Contractor, acting reasonably.

16.8 The City may take possession of and use any completed portion of the Work regardless of the time for completion of the Work. Such possession or use will not be construed as final acceptance of the Work or portion.

## 17. PERSONNEL

- 17.1 Superintendent: The Contractor shall employ a competent senior representative at the Place of Work (the “**Superintendent**”) who shall have the responsibility to ensure that the Work is performed in compliance with the Contract Documents. The Contractor shall also employ necessary assistants for the Superintendent and the Superintendent and assistants shall be in attendance at the Place of Work while Work is being performed.
- 17.2 The Superintendent shall represent the Contractor at the Place of Work and instruction given to the Superintendent by the Consultant shall be held to have been given to the Contractor.
- 17.3 If the competence or performance of the Superintendent is not satisfactory to the Consultant then, on written request from the Consultant, the Contractor shall provide a satisfactory replacement. The Contractor shall not change the Superintendent without the consent of the Consultant, such consent not to be unreasonably withheld.
- 17.4 Workers: The Contractor shall maintain good order and discipline among the Contractor’s employees and the subcontractors engaged in the Work. The Contractor shall not employ, or permit subcontractors to employ, workers who are not skilled in the assigned task. The Contractor shall employ sufficient workers to perform the Work in compliance with the Construction Schedule.
- 17.5 Compliant with COVID 19 Policy - It is a material term of this Contract that the Contractor, and any personnel and subcontractors performing the Work who (a) will enter City facilities or (b) will be in close physical proximity to City staff outdoors, comply with the City’s COVID 19 policy(ies) and requirements, including with respect to Contractor’s personnel will be fully vaccinated against COVID-19 and require their personnel to provide proof of vaccination status in a form acceptable to the City prior to beginning work each day on-site. The Contractor will immediately remove any personnel or subcontractors who do not meet, maintain or comply with any such polices and requirements.

The personal information collected will be held in confidence by the City and will be used only to monitor compliance with, and to administer, the City’s vaccination policies. The City will collect this personal information under s. 26(c) of the *Freedom of Information and Protection of Privacy Act*.

## 18. CODES AND REGULATIONS

- 18.1 The Contractor will perform the Work in full compliance with all applicable federal, provincial and municipal enactments, codes and regulations.
- 18.2 The Contractor shall comply with all applicable laws, policies, building codes, by-laws, procedures and instructions provided by the City.

## 19. CONTRACTOR'S WARRANTY

- 19.1 The Contractor represents, warrants and guarantees to the City that:
- (a) the Work will, in all respects, be constructed in a good and workmanlike manner;

- (b) the Work will be constructed in accordance with all applicable laws in effect at the date of the Contract and in accordance with the best current and prevailing industry practices;
  - (c) the Work will be supplied, procured, fabricated, installed, constructed and completed in accordance with all requirements of the Contract;
  - (d) all Work will be free from defects or deficiencies arising from faulty construction, faulty material, faulty equipment, faulty installation or faulty workmanship;
  - (e) the Work as constructed will be fit for the purpose intended;
  - (f) title to all Work and all parts thereof shall be free and clear of all liens, charges, encumbrances and adverse claims whatsoever; and
  - (g) no part of the Work shall constitute an infringement of any patent, trademark, copyright or other proprietary interest.
- 19.2 The Contractor agrees to correct any deficiency in the Work arising from faulty construction, faulty material, faulty equipment, faulty installation or faulty workmanship, which appear:
- (a) in the case of any roof, in the period of five (5) years after Substantial Performance of the Work;
  - (b) for other Work, excluding Work covered by a warranty greater than twelve (12) months, in the period of twelve (12) months after the date of Substantial Performance of the Work; and
  - (c) for other Work in the period of any warranties.
- 19.3 The Contractor shall undertake all repairs or replacements at times that will minimize interference with the City's operations.
- 19.4 Nothing contained herein limits the rights of the City in relation to recovery for latent deficiencies in the Work or otherwise limits the rights of the City at law or in equity.
- 19.5 The Contractor shall not be relieved of its warranty obligations by reason of inspection, testing or acceptance of the Work or any portion thereof, or the issuance of a Certification of Completion, or a Certificate of Total Performance, or payment to the Contractor of any money under the Contract.

## **20. WAIVERS**

- 20.1 The Contractor's application for the Certification of Completion shall constitute a waiver and release by the Contractor of any and all claims arising out of or relating to the Contract to the date of Substantial Performance. This waiver shall include without limitation those that might arise from the negligence or breach of contract by the City, the City's Representative and their respective employees, agents, officers and contractors, but does not include claims made by the Contractor in writing prior to such application in accordance with the provisions of the Contract Documents and delivered to the City's Representative prior to date of Substantial Performance and still unsettled.
- 20.2 The Contractor's application for the Certificate of Total Performance shall constitute a waiver and release by the Contractor of any and all claims arising out of or relating to the Contract that have arisen between the date of Substantial Performance and the date of the Certificate of Total Performance. This waiver shall include those that might arise from the negligence or breach of contract by the City, the City's Representative, and their respective employees, agents, officers and contractors, but does not include claims by the Contractor

in writing prior to such application in accordance with the provisions of the Contract Documents and delivered to the City's Representative and still unsettled.

## **21. SUBSTANTIAL PERFORMANCE**

21.1 The City or its Consultant will, after receipt of a written application from the Contractor for a Certification of Completion, make an inspection and assessment of the Work and issue a Certification of Completion or if the City decides that Substantial Performance has not been achieved, consult with the Contractor and advise the Contractor of the Work required to achieve Substantial Performance.

21.2 Prior to making application for Substantial Performance of the Work, the Contractor shall submit to the Consultant or City the following:

- (a) letters of assurance for professional design and review from those professionals engaged by the Contractor under the provisions of the Contract, including applicable sealed shop drawings;
- (b) all required manufacturer's inspections, certifications, guarantees, warranties as specified in the Contract Documents;
- (c) all maintenance manuals, operating instructions, maintenance and operating tools, replacement parts or materials as specified in the Contract Documents;
- (d) certificates issued by all permit issuing authorities indicating approval of all installations, work and improvements requiring permits;
- (e) certificates issued by all testing, commissioning, cleaning, inspection authorities and associations as applicable or specified in the Contract Documents; and
- (f) all required record Drawings and as built and as-installed documents in the form specified in the Contract Documents, including the as-built Drawings.

If it is impracticable, with reasonable diligence and attention, for the Contractor to have obtained one or more of the items listed above prior to making application for Substantial Performance of the Work, then delivery of such items may be deferred until the date that is 30 days following Substantial Performance of the Work.

21.3 Together with its request or application for the Certificate of Completion of the Work, the Contractor shall provide to the Consultant and the City the following:

- (a) a sworn declaration in a form acceptable to the Consultant that all amounts relating to the Work, due and owing as of the end of the month covered by the invoice to third parties including all subcontractors and suppliers, have been paid;
- (b) a current clearance letter from Workers' Compensation Board confirming that the Contractor is in good standing with and that all required remittances and assessments have been made to the Workers' Compensation Board;
- (c) a statement compiling and reconciling all Change Orders and Change Directives; and
- (d) any other documents to be submitted by the Contractor as specified in the Contract Documents or reasonably required by the Consultant or the City.

21.4 The City shall pay any builder's lien holdback as required by the *Builders Lien Act*, or on such other date as required by law, but the City may hold back the amounts for any deficiencies or filed builder's liens.

21.5 The Consultant, R.F. Binnie & Associates Ltd., shall be the payment certifier responsible for payment certification for the Contractor under the *Builders Lien Act*. The Contractor shall

be the person responsible for payment certification for all subcontractors, including the subcontractors, as required under the *Builders Lien Act*.

## **22. TOTAL PERFORMANCE**

- 22.1 Before applying for a Certificate of Total Performance, the Contractor will provide to the City the following:
- (a) complete sets of digital drawings and specifications, in reproducible form, showing the as-built Work;
  - (b) complete sets of maintenance manuals for any and all equipment comprised in the Work; and
  - (c) the results of quality control testing by the Contractor.
- 22.2 The Contractor may apply for a Certificate of Total Performance and the procedure and requirements for the issuance of the Certificate of Total Performance shall include the provision by the Contractor of the sworn declaration and Workers' Compensation Board compliance documentation.

## **23. WORKERS' COMPENSATION BOARD AND OCCUPATIONAL HEALTH AND SAFETY**

- 23.1 The Contractor agrees that it shall, at its own expense, procure and carry, or cause to be procured, carried and paid for, full Workers' Compensation Board coverage for itself and all workers, employees, servants and others engaged in the supply of the Goods and Services. The Contractor agrees that the City has the unfettered right to set off the amount of the unpaid premiums and assessments for the Workers' Compensation Board coverage against any monies owing by the City to the Contractor. The City will have the right to withhold payment under this Contract until the Workers' Compensation Board premiums, assessments or penalties in respect of the Goods and Services have been paid in full.
- 23.2 The Contractor will provide the City with the Contractor's Workers' Compensation Board registration number and a letter from the Workers' Compensation Board confirming that the Contractor is registered in good standing with the Workers' Compensation Board and that all assessments have been paid to the date thereof prior to the City having any obligations to pay monies under this Contract.
- 23.3 The Contractor agrees that it is the prime contractor for the Work as defined in the *Workers Compensation Act, R.S.B.C. 2019, c.1*, as amended. The Contractor will have a safety program in place that meets the requirements of the Workers' Compensation Board Occupational Health and Safety Regulation and the *Workers Compensation Act*. As prime contractor, the Contractor will be responsible for appointing a qualified coordinator for insuring the health and safety activities for the location of the Services. That person will be the person so identified in Schedule B of this Contract, and the Contractor will advise the City immediately in writing if the name or contact number of the qualified coordinator changes.
- 23.4 Without limiting the generality of any other indemnities granted by the Contractor in this Contract, the Contractor shall indemnify and save harmless the Indemnitees from and against all claims, demands, causes of action, suits, losses, damages, costs, liabilities, expenses, judgements, penalties and proceedings (including all actual legal costs) which any of the Indemnitees incur, suffer or are put to arising out of or in any way related to unpaid Workers' Compensation Board assessments owing from any person or corporation

engaged in the performance of this Contract or arising out of or in any way related to the failure to observe safety rules, regulations and practices of the Workers' Compensation Board, including penalties levied by the Workers' Compensation Board.

- 23.5 The Contractor will ensure compliance with and conform to all health and safety laws, by-laws or regulations of the Province of British Columbia, including without limitation the *Workers Compensations Act* and Regulations pursuant thereto.
- 23.6 The City may, on twenty-four (24) hours written notice to the Contractor, install devices or rectify any conditions creating an immediate hazard existing that would be likely to result in injury to any person. However, in no case will the City be responsible to ascertaining or discovering, through inspections or review of the operations of the Contractor or otherwise, any deficiency or immediate hazard.
- 23.7 The Contractor understands and undertakes to comply with all Workers' Compensation Board Occupational Health and Safety Regulations for hazardous materials and substances, and in particular with the "Workplace Hazardous Materials Information System (WHMIS)" Regulations. All "Material Safety Data Sheets (MSDS)" shall be shipped along with the Goods and any future MSDS updates will be forwarded.

## **24. INSURANCE**

- 24.1 The Contractor will obtain and carry, in forms and with insurers satisfactory to the City:
- (a) commercial general liability insurance with a limit of five million (\$5,000,000) dollars inclusive per occurrence for bodily injury, death and damage to property;
  - (b) the insurance shall include coverage for:
    - broad form products and completed operations,
    - City's and contractor's protective liability,
    - contractor's contingent liability,
    - blanket written contractual,
    - contingent employer's liability,
    - personal injury liability,
    - non-owned automobile,
    - cross liability,
    - employees as additional insured's, and
    - broad form property damage;
- and where such further risk exists:
- shoring, blasting, excavating, underpinning, demolition, removal, pile-driving and caisson work, work below ground surface, tunnelling and grading, as applicable, and
  - operation of attached machinery.
- (c) product and completed operations liability insurance, to remain in full force and effect for a period of not less than twenty four (24) months following completion of the Work;
  - (d) if applicable, professional errors and omissions insurance in an amount not less two million (\$2,000,000) dollars insuring all professionals providing the Services from liability resulting from errors or omissions in the performance of the Services, with a 12-month maintenance period, for the Contractor's professional contractors and sub-contractors;



- (e) Automobile Liability insurance on all vehicles owned, operated or licensed in the name of the Contractor in an amount not less than less three million (\$3,000,000 dollars);
- (f) the contractor shall require similar limits if insurance as in para. 244.1 (a),(b) & (c). The contractor shall, upon request, provide copies of all insurance certificates for subcontractors.
- (g) the insurance will contain a waiver of the insurer's rights of subrogation against all insured

24.2 The Contractor will provide proof of the required insurance coverage prior to commencing the Work. Such proof will be in the form of a City of Surrey certificate of insurance.

24.3 The Contractor acknowledges that any requirement or advice by the City as to the amount of coverage under any policy of insurance will not constitute a representation by the City that the amount required is adequate and the Contractor acknowledges and agrees that it is solely responsible for obtaining and maintaining policies of insurance in adequate amounts.

24.4 If requested to do so, the Contractor will provide the City with a copy of insurance policies relating to the Work.

## **25. INDEMNIFICATION**

25.1 The Contractor shall indemnify and hold harmless the City, its elected officials, its officers, agents and employees (collectively the "Indemnitees") from and against claims, demands, losses, costs, damages, actions, suits or proceedings by third parties that arise out of, or are attributable to, any act or omission or alleged act or omission of the Contractor, the Contractor's agents, employees or subcontractors or suppliers in performance of the Contract.

25.2 The City shall indemnify and hold harmless the Contractor, its agents and employees from and against claims, demands, losses, costs, damages, actions, suits, or proceedings arising out of or which are attributable to a lack of or defect in title or an alleged lack of or defect in title to the Place of Work.

## **26. DEFECTIVE WORK**

26.1 Work that is defective ("Defective Work"), whether the result of poor design, poor workmanship, use of defective materials or damage through carelessness or other acts, and whether incorporated in the Work or not, which has been rejected by the City as failing to conform to the Contract will be removed promptly by the Contractor and replaced and re-executed promptly and properly at the Contractor's expense.

## **27. DEFAULT**

27.1 If the Contractor:

- (a) is adjudged bankrupt, makes a general assignment for the benefit of creditors, or a receiver is appointed on account of its insolvency;
- (b) fails to supply competent supervision, properly skilled workers or proper materials;
- (c) fails to make prompt payment to its contractors, suppliers or workers;
- (d) fails to observe, or breaches the provisions of the Contract;

- (e) fails to remove and replace Defective Work;
- (f) abandons the Work; or
- (g) fails to adhere to the Construction Schedule;

the Contractor is in default of the Contract and the City may give the Contractor written notice to remedy such default. If the Contractor does not commence correction of such default within five (5) business days of receiving such notice and diligently pursue correction of such default, the City may suspend the Work or terminate the Contract, without prejudice to any other right or remedy the City may have.

- 27.2 The parties agree that if the City terminates the Contract under the conditions set out above, the City shall pay the Contractor:
- (a) for all Work performed, plus reimbursement for expenditures made on account of the remaining Work, but shall not pay for profit and Overhead on account of the remaining Work or any additional costs incurred because of the termination.
- 27.3 If the City terminates the Contract, the City may:
- (a) take possession of the Work and materials, and utilize the Contractor's machinery and equipment at the Place of Work to the extent third party rights are not impaired, and bring the Work to completion by whatever method the City may deem expedient; and
  - (b) upon completion of the Work, charge the Contractor the full cost of completing the Work, as certified by the Consultant, including remedying any deficiencies in the Work.

## **28. CORRECTION BY CITY**

- 28.1 In addition to the right of termination, if the Contractor fails to comply with a provision of the Contract, including failure to remove and replace Defective Work, the City may, without prejudice to any other remedy it may have, correct such default and charge the Contractor the full cost of correcting the default.

## **29. DISPUTE RESOLUTION**

- 29.1 The parties will make reasonable efforts to resolve any dispute, claim, or controversy arising out of this Contract or related to this Contract ("Dispute") using the dispute resolution procedures set out in this section.

### **Negotiation**

The parties will make reasonable efforts to resolve any Dispute by amicable negotiations and will provide frank, candid and timely disclosure of all relevant facts, information and documents to facilitate negotiations.

### **Mediation**

If all or any portion of a Dispute cannot be resolved by good faith negotiations within 30 days, either party may by notice to the other party refer the matter to mediation. Within 7 days of delivery of the notice, the parties will mutually appoint a mediator. If the parties fail to agree on the appointment of the mediator, then either party may apply to the British



Columbia International Commercial Arbitration Centre for appointment of a mediator. The parties will continue to negotiate in good faith to resolve the Dispute with the assistance of the mediator. The place of mediation will be Surrey, British Columbia. Each party will equally bear the costs of the mediator and other out-of-pocket costs, and each party will bear its own costs of participating in the mediation.

### **Litigation**

If within 90 days of the request for mediation the Dispute is not settled, or if the mediator advises that there is no reasonable possibility of the parties reaching a negotiated resolution, then either party may without further notice commence litigation.

## **30. ASSIGNMENT AND SUBCONTRACTS**

- 30.1 The Contractor agrees to preserve and protect the rights of the parties under the Contract with respect to Work to be performed under subcontract and to:
- (a) enter into contracts or written agreements with subcontractors to require them to perform their work in accordance with and subject to the terms and conditions of the Contract Documents; and
  - (b) be as fully responsible to the City for acts and omissions of subcontractors and of persons directly or indirectly employed by them as for acts and omissions of persons directly employed by them. The Contractor agrees that he will incorporate the terms and conditions of the Contract Documents into all subcontract agreements entered into with subcontractors.
- 30.2 The Contractor agrees to employ those subcontractors proposed by in writing and accepted by the City at the signing of the Contract. The Contractor shall not, without the written consent of the City, change a subcontractor who has been engaged in accordance with the Contract.
- 30.3 The City may, for reasonable cause, object to the use of a proposed subcontractor and require the Contractor to employ one of the other subcontract tenderers.
- 30.4 In the event that the City requires a Change from a proposed subcontractor, the Contract Price shall be adjusted by the difference in cost and mark-up occasioned by such required Change.
- 30.5 The Contractor shall not be required to employ as a subcontractor a person or firm to whom he may reasonably object.
- 30.6 The Contractor may, upon reasonable request and at its discretion, provide to a subcontractor information as to the percentage or quantity of the subcontractor's work which has been certified for payment.
- 30.7 Nothing contained in the Contract Documents shall create a contractual relationship between a subcontractor and the City.

## **31. NOTICES**

- 31.1 Any notice, report or other document that either party may be required or may wish to give to the other should be in writing, unless otherwise provided for, and will be deemed to be validly given to and received by the addressee, if delivered personally, on the date of such

personal delivery, if delivered by facsimile, on transmission, or it by mail, five calendar days after posting. The addresses for delivery will be as follows:

- (a) The City:
- City of Surrey –Planning & Development  
13450 – 104 Avenue  
Surrey, B.C., Canada, V3T 1V8
- Attention: Tullio Fontana  
Engineering Assistant
- Business Fax: 604-599-8794  
Business Email: tfontana@surrey.ca
- (b) The Contractor: [Insert full legal name and business address]
- \_\_\_\_\_
- \_\_\_\_\_
- Attention: [Insert Contractor contact name]  
[Insert title]
- Business Fax: <<Insert>>  
Business Email: <<Insert>>
- (c) The Consultant (Payment Certifier): R.F. Binnie & Associates Ltd.  
314-9440 202 Street  
Langley, B.C., V1M 4A6
- Attention: Kyle Neufeld  
Project Manager
- Telephone: 604-351-9830  
Business Email: kneufeld@binnie.com

## 32. FORCE MAJEURE

- 32.1 Each party will be excused from performance under this Contract for any period and to the extent that it is prevented from or delayed in performing any obligations pursuant to this Contract, in whole or in part, by any Force Majeure Event. The affected party may invoke this section by promptly notifying the other party in writing of the nature and estimated duration of the suspension of the party's performance. In such event, the affected party will be excused from further performance of obligations so affected for so long as such Force Majeure Event prevails and such party continues to use its best efforts to recommence performance whenever and to whatever extent possible without delay (except that a party is not required by this Section to compromise its position with respect to or settle any labour dispute in order to satisfy its obligations hereunder). For the avoidance of doubt, nothing in

this Section will affect the City's right to terminate this Contract for convenience as provided in Section 27.

- 32.2 For the purposes of this Contract, "Force Majeure Event" will mean the occurrence of an event or circumstance beyond the reasonable control of a party, provided that (i) the non-performing party is without fault in causing or preventing such occurrence and (ii) such occurrence cannot be circumvented through the use of commercially reasonable alternative sources, workaround plans or other means. Force Majeure Events will include acts of federal, provincial, local or foreign governmental authorities or courts, war or insurrection, civil commotion, catastrophic events, including without limitation earthquakes, catastrophic weather conditions, pandemics, fires, floods, storms or other elements of nature or acts of God, and labour disturbances that affect the party claiming force majeure.

### **33. EXTRA WORK**

- 33.1 The City may invite the Contractor to perform Extra Work as part of this Contract by issuing a Contemplated Change Order for the Extra Work.

- 33.2 It is a condition of a Contract that the City is not obligated at any time to make a request to the Contractor to perform Extra Work. The City reserves the right to retain the services of other independent contractor(s) or utilize its own employees to perform any Extra Work that is required to be performed and the Contractor and its subcontractors, if any, shall cooperate fully with other independent contractor(s) retained by the City to perform and/or complete any Extra Work and shall so carry on their work that other cooperating

contractors shall not be hindered, delayed, or interfered with in the progress of their work, and so that all of such work shall be finished and complete of its kind.

- 33.3 The Contractor is under no obligation to accept an invitation to perform Extra Work and the City is under no obligation to offer work that might be undertaken by the Contractor as Extra Work.

- 33.4 If the City issues a Contemplated Change Order for Extra Work, the Contractor shall promptly either decline the opportunity to perform the Extra Work, or respond with a Quotation.

- 33.5 The City is under no obligation to accept the Contractor's Quotation for Extra Work and may elect to have the Extra Work performed by others.

- 33.6 In no event shall the Contractor proceed with any work that the Contractor intends or expects to be treated as Extra Work without first receiving a written Change Order approving the work as Extra Work.

### **34. GENERAL**

- 34.1 The Contract contains the entire agreement between the City and the Contractor and may not be amended except in writing and signed by both parties.

- 34.2 All schedules and appendices attached to the Contract will be read and construed as forming part of the Contract.

- 34.3 The Contract will be interpreted in accordance with the laws of the Province of British Columbia.
- 34.4 The headings are included in the Contract for convenience only and will not be referred to in interpreting the Contract.
- 34.5 No consent or waiver by either party to or of any breach or default by the other under the Contract will be effective unless in writing, nor will such consent or waiver be relied on as consent to or waiver of any other breach or default of the same or any other obligation.

34.6 Each party will, at its own expense, execute and deliver all such further agreements and documents and do such acts and things as may be reasonably required to give effect to the Contract.

**IN WITNESS WHEREOF** the parties hereto have executed the Contract on the day and year first above written.

**CITY OF SURREY**

by its authorized signatory(ies):

\_\_\_\_\_  
Insert Name of Person Signing

\_\_\_\_\_  
Insert Name of Person Signing

\_\_\_\_\_  
Insert Title of Person Signing

\_\_\_\_\_  
Insert Title of Person Signing

**<<INSERT FULL LEGAL NAME OF CONTRACTOR>>**

by its authorized signatory(ies):

\_\_\_\_\_  
Insert Name of Person Signing

\_\_\_\_\_  
Insert Name of Person Signing

\_\_\_\_\_  
Insert Title of Person Signing

\_\_\_\_\_  
Insert Title of Person Signing

## **SCHEDULE B – APPENDIX 1 SPECIAL PROVISIONS**

### **S.P.1 Definitions**

In these Special Provisions, unless the context otherwise requires,

“Section” means section of the Specifications or the Conditions of Contract.

“Item” means item of Fees and Payments – Schedule C – Form of Quotation.

### **S.P.2 Scope of Work**

The scope of Work covered under this project consists of the furnishing of all superintendence, overhead, skilled labour, materials, tools, equipment, insurance, fuel, transportation and all things necessary for and incidental to the satisfactory performance and completion of construction and renovation of South Surrey Indoor Arena Parking Lot Rehabilitation, located at 2199 148 Street, Surrey, British Columbia (the “Place of Work”) in strict accordance with the Specifications and accompanying Drawings and subject to all terms and conditions of the Contract.

Job site location is 2199 148 Street, Surrey, British Columbia, Canada.

The Work consists of but is not necessarily limited to the following:

The detailed scope of work is as described on the Drawings (listed below), Special Provisions (Schedule B – Appendix 1), and Supplementary Specifications (Project) (Schedule B- Appendix 2).

Where a project specification does not exist, the default project specification shall adhere to MMCD specifications (excluding measurement and payment descriptions). The City has project specifications to MMCD which is included herein. These project specifications shall take precedence over the basic MMCD specifications.

The lack of and/or omission of detailed specifications does not minimize the acceptable levels of service and only the best commercial practices are acceptable.

Contractor to comply with all BC Plumbing Code, BC Fire Marshal, BC Workers’ Compensation Board, National Building Code of Canada, BC Boiler Inspector, BC Electrical Inspector, National Fire Protection Association, and any other authorities having local jurisdiction. Failure to abide by these rules and regulations will result in being immediately escorted from the work site.

### **S.P.3 Liquidated Damages For Late Completion**

If the Contractor fails to meet the Milestone Date for Substantial Performance, or any other specified Milestone Date, as set out in Schedule C - Form of Quotation, as may be

adjusted pursuant to the provisions of the Contract Documents, then the City may deduct from any monies owing to the Contractor for the Work:

- (1) as a genuine pre-estimate for the City's increased costs for the Contract Administrator and their field representative caused by such delay an amount of \$100.00 per calendar day, or pro rata portion, for:
  - a. each day that the Work, or portion of Work, was completed after the specified Milestone Date for that applicable Work, or portion of Work; and
  - b. each day that actual Substantial Performance is achieved after the Substantial Performance Milestone Date; plus.
- (2) all direct out of pocket costs, such as, but not limited to: the City's own staff costs; costs for safety, security, or equipment rental required; and costs for temporary surface restoration and increased temporary maintenance which may be reasonably incurred by the City as direct result of such delay; plus
- (3) any loss to the City of third-party funding which the City was to receive if the Work, or a particular portion thereof, was not completed before a Milestone Date.

If the monies owing to the Contractor are less than the total amount owing by the Contractor to the City under (1), (2) or (3) then any shortfall shall immediately, upon written notice from the City, and upon Substantial Performance, be due and owing by the Contractor to the City.

#### **S.P.4 Consultant**

The Consultant R.F. Binnie & Associates Ltd., 314-9440 202 Street, Langley, BC, V1M 4A6. Telephone 604-574-3336, E-mail: [kneufeld@binnie.com](mailto:kneufeld@binnie.com), represented by: Kyle Neufeld will be the City's representative during the performance of the Work until the Work is complete. The Consultant will advise and consult with the City. The City's instruction(s) to the Contractor may be forwarded through the Consultant.

The Consultant may periodically visit the Work site(s) to become familiar with the progress of the Work, the quality of the Work being provided and to determine if the Work is proceeding in accordance with the Contract Documents.

#### **S.P.5 Payment Certifier**

The Payment Certifier is: R.F. Binnie & Associates Ltd., 314-9440 202 Street, Langley, BC, V1M 4A6, Telephone 604-574-3336, E-mail: [kneufeld@binnie.com](mailto:kneufeld@binnie.com), represented by: Kyle Neufeld, Project Manager.

#### **S.P.6 Project Manager**

The Project Manager is City of Surrey, 13450 014 Avenue, Surrey, BC, V3T 1V8 Telephone: (604) 592-7056 E-mail: [TFontana@surrey.ca](mailto:TFontana@surrey.ca), represented by: Tullio Fontana, Engineering Assistant.

### **S.P.7 Schedule of Quantities and Prices**

This Contract is a combination of unit prices and lump sums.

Any Work item that is not implicitly described, or inferred, as being included in any regular item or optional item in the Schedule of Prices shall be included in the lump sum price proposed for 'Miscellaneous Work'.

For unit price items, the number of units for each item (i.e., quantities) as listed in the Schedule of Prices has been estimated. Actual quantities will vary. Payment will be made based on the measurement of the actual quantity of Work incorporated into the Contract.

The unit prices for each item will be applicable regardless of the variation in the actual quantity as compared to the estimated quantity. No adjustment to the unit price will be considered as a result of such variation.

Each project location is to be priced separately.

### **S.P.8 Coordination**

The Contractor will be responsible for coordinating with other contractors City forces, outside agencies and others as required throughout the Contract. While it is not an all-inclusive list of potential coordination requirements, the following list of known activities that the Contractor should be aware of when planning for coordination:

#### Other contractors

The Contractor will be required to coordinate their schedule and work program with the following construction activities, which will be tendered to other contractors by the City and will be construction concurrent with the Contract.

"NONE"

### **S.P.9 Availability of Place of Work**

The Place of Work is available for the commencement of the Work beginning July, 2022. The anticipated start date is July 4<sup>th</sup>, 2022. The Contractor will schedule the Work accordingly.

### **S.P.10 Quality Assurance**

The Work shall be performed by a Contractor experienced in pavement rehabilitation of a similar nature and scope. Subject to approval of the City, the Contractor may subcontract any work to be performed under this Contract. However, the election to subcontract work shall not relieve the Contractor from responsibility or liability which it has assumed under this Contract and the Contractor shall remain liable to the same extent that its liability would attach, as if the Work had been performed by the Contractor's own employees.

All materials and hardware to be supplied by the Contractor, which are not specifically described herein, shall be of suitable construction, composition and quality to achieve their intended function.



### **S.P.11 Job Conditions**

The Contractor shall be familiar with the project location and how the existing conditions will affect their work. This is so that no misunderstanding may arise afterwards as to the character or as to the extent of the work to be done; likewise, in order to advise and acquaint themselves with all precautions to be taken in order to avoid injury to person or property of another. No additional compensation will be granted because of any unusual difficulties or City's special requests that may be encountered in the execution of any portion of the work.

### **S.P.12 Environmental Protection**

The Contractor warrants that it will not produce or discharge in any manner or form, directly or indirectly, chemicals or toxic substances into the environment and that all equipment used will not pose a hazard to, or harm or adversely affect anyone coming into contact with it and covenants and agrees to provide the City with an environmental plan (where applicable), acceptable to the City, which plan shall outline the procedures to be followed by the Contractor to prevent the production or discharge of chemicals or toxic substances into the environment and the actions to be taken should the discharge occur.

The Contractor will be responsible to take all necessary measures to comply with the requirements of the Federal and Provincial environmental protection agencies, City by-laws, the *Waste Management Act*, R.S.B.C. 1996, c. 482, as amended and any other applicable acts and regulations in respect to air, earth and water pollutants.

The Contractor will report to the City immediately if any hazardous or toxic materials are found or discovered. Such materials are to be left untouched and the area is to be marked and cordoned off to prevent any access to the workers and the public.

The Contractor will be responsible to establish and submit a waste disposal plan to the City for review prior to commencing the Work.

### **S.P.13 Safety**

The Contractor shall be solely responsible for construction safety at the Place of Work as and to the extent required by applicable construction safety legislation, regulations and codes, including *Workers Compensation Act* and applicable regulations, and by good construction practice.

Safety – Fall Protection - The Contractor and any trade contractor shall include for all fall protection equipment and requirements necessary to complete scope of Work in a safe manner and in compliance with the site safety plan, which includes: Fall protection must be worn when working at a height over 6 ft. or as the hazards present necessity.

Safety – On-Site Hazards and Utilities Present – Before commencing any Work at the Place of Work, the Contractor is to make themselves aware of any and all on-site hazards including but not limited to underground and overhead utilities near to the Work area and to take every precaution necessary to eliminate any risk that may exist. If an on-site hazard exists that is causing or may cause injury to any person(s), the Contractor is to take immediate action to mitigate risk and damage, and then notify the City and the City's consultant (if any).

### **S.P.14 Traffic Management**

The Contractor shall comply with all the requirements of applicable laws, rules, regulations, codes and orders of the City and other appropriate authorities concerned with work on streets or highways and shall post proper notices and/or signals, and provide necessary barriers, guards, lights, flagmen or watchmen as may be necessary for proper maintenance of traffic and protection of persons and property from injury or damage. All costs involved in respect to the above requirements will be deemed to be included in the Total Quotation Price.

### **S.P.15 Construction Access and Traffic Maintenance**

The designated access to and from the construction site must be approved by the City. All construction traffic must use the designated access including heavy equipment, trucks and workers' personal vehicles.

Construction access to the Place of Work areas within existing building for workers and delivery of materials shall be designated by the City. No other existing exits or entrances shall be used by workers for access or for delivery of materials.

The Contractor shall conduct construction operations with minimum interference to adjacent roadways, sidewalks and access facilities in general and shall keep such areas free from materials, debris and equipment at all times. The Contractor shall not close or obstruct existing roadways, sidewalks, parking areas or delivery points and shall not place or store materials or park cars on same.

The Contractor shall cooperate in all ways with the City in all matters concerning necessary interference with normal operation of the Place of Work. Minimizing disruption of normal facility/site operation and vehicular movements at the Place of Work is an essential requirement of the Contract.

The Contractor shall:

- (a) Include project phasing strategies in the Construction Schedule to minimize traffic disruption on the Place of Work.
- (b) Should provide one (1) week minimum notice to the City, previous to any disruption or alteration of access to the Place of Work. The Contractor shall provide all signs, pylons and flag persons necessary to direct vehicular traffic around work in progress.
- (c) The Contractor shall maintain access to existing fire hydrants and Siamese connections and shall keep entrances and exits to existing and adjacent buildings clear at all times.

### **S.P.16 Proposed Substitutions**

Acceptance of material specifications that are an equal or higher level of quality compared to the material specified will not be unreasonably withheld. Quotations for equipment substitutions to be made as separate line items and as additive or deductive alternates to the base equipment bid.

Evaluation of the substitutions to be made solely by the City whose decision shall be final.

### **S.P.17 Manuals**

Installation and Operator's manuals should accompany equipment delivered. Electrical, mechanical, and plumbing booklets should be provided to the City, as per the specifications.

All manual(s) should be furnished prior to payment and delivered to the City. Failure to deliver all manual(s) that are ordered may result in non-payment until all manual(s) are received.

### **S.P.18 Hours of Work**

Refer to the City of Surrey applicable bylaws for acceptable work hours.

No work is to be performed outside of these acceptable work hours without written approval from the City, and with approval by obtaining a noise variance if required.

All work shall conform to local bylaws, including building and parking bylaws and municipal guidelines and regulations. This includes Building Bylaws and Noise Restrictions, which will apply to all work being completed. Where work or the work schedule does not permit compliance with the Bylaws, the Contractor shall request permission from the City for special exemptions from the bylaws. No extra compensation, in any form (e.g., overtime, etc.) will be given without prior written approval from the City.

### **S.P.19 Damage**

The Contractor will be responsible for any and all damages to property or persons and for any losses or costs to repair or remedy the Works as a result of any negligent act or omission, or misconduct in the performance of the Works and its subcontractor's Work and shall indemnify and hold harmless the City, its officers, agents and employees from all suits, claims, actions or damages of any nature whatsoever resulting therefrom unless such loss, damage, injury or loss results from or arises out of the error, omission and/or negligent acts of the City, or its officers, for subsequent correction of any such error, omission and/or negligent acts or of its liability for loss or damage resulting therefrom. Except as to professional liability, these indemnities shall not be limited by the listing of any insurance coverage.

### **S.P.20 Worksite Conduct**

All labourers and workers, while working in and around the 2199 148 Street, Surrey, British Columbia, and the City facilities, shall act in a professional manner. The Contractor is to enforce proper discipline and decorum among all labourers and workers on the worksite and is to control, among other things: 1) noise, including music; 2) the use of offensive language; 3) smoking or drinking of alcoholic beverages on the worksite; 4) physical violence; 5) riding in the passenger elevators; 6) thievery; and 7) the transportation of articles or materials deemed hazardous. If the City determines, in its sole discretion, that any labourer need to be removed due to his or her failure to comply with the terms of this provision, the Contractor will remove such labourers from the worksite immediately.

Alcohol and drugs are not tolerated on this site at any time including anyone deemed to be under the influence shall be escorted off site.

### **S.P.21 Cleanliness and Disposal of Unwanted Materials**

Continuous daily clean up of the work areas shall be performed by the Contractor and trade contractor throughout the performance of the Work and will be undertaken in accordance with the Contractor's waste management plan. Clean up of waste products and debris generated by the Contractor and any trade contractor outside of the building and on the site shall be the responsibility of the Contractor. Should the City be required to clean up the work of the Contractor or trade contractor the cost of such clean up will be recovered from the Contractor.

The Contractor is to dispose of all debris, trash and unsuitable materials collected under this Contract off site. The Contractor is solely responsible for any and all damages done, or regulations violated in the disposal of waste materials and for any other actions, which the Contractor performs.

The Contractor warrants that it will produce or discharge in any manner or form, directly or indirectly, chemicals or toxic substances into the environment and that all equipment used will not pose a hazard to, or harm or adversely affect anyone coming into contact with it and covenants and agrees to provide the City with an environmental plan (where applicable), acceptance to the City, which plan shall outline the procedures to be followed by the Contractor to prevent the production or discharge of chemicals or toxic substances into the environment and the actions to be taken should the discharge occur.

The Contractor is responsible to take all necessary measures to comply with the requirements of the Federal and Provincial environmental protection agencies, City by-laws, the *Waste Management Act*, R.S.B.C. 1996, c. 482, as amended and any other applicable acts and regulations in respect to air, earth and water pollutants.

### **S.P.22 Accidents; Equipment Safety**

Any and all accidents, regardless of how minor, involving another person, private property, or vehicle, shall be reported immediately to the Surrey R.C.M.P. and a report requested. The City shall also be contacted immediately and be provided a copy of any reports.

The Contractor shall assume all responsibility for damages to property or injuries to persons, including accidental death, attorneys fee and costs of defense which may be caused by Contractor's performance of this Contract, whether such performance be by itself, its subcontractor, or anyone directly or indirectly employed by Contractor or its subcontractors and whether such damage shall accrue or be discovered before or after termination of this Contract.

The Contractor's equipment operators shall maintain good safety and driving records, and use extreme caution during the performance of the Work.

### **S.P.23 Permits and Fees**

The Contractor is to secure and pay for any additional permits, and governmental fees, licenses and inspection necessary for proper execution and completion of the Work which is customarily secured after execution of an agreement and which is legally required. The Contractor is to comply with and give notices required by laws applicable to performance of the Work.

#### **S.P.24 Final Completion and Payment**

When the Work is finally complete and the Contractor is ready for a final inspection, the Contractor is to notify the City and the Consultant, in writing. Thereupon, the Consultant will perform a final inspection of the Work. If the Consultant confirms that the project is complete including all deficiencies, is in full accordance with this Contract and the Contractor has performed all of its obligations, is hereby entitled to submit for final payment, subject to the *Builders Lien Act*.

#### **S.P.25 Workmanship**

- (a) General: Workmanship shall be of best quality, executed by workers experienced and skilled in respective duties for which they are employed. Do not employ any unfit person or anyone unskilled in their respective duties. The City reserves the right to dismiss for site, workers deemed incompetent, careless, insubordinate or otherwise objectionable. Decisions as to quality of fitness of workmanship in cases of dispute rest solely with the City, whose decision shall be final.
- (b) Coordination: Ensure cooperation of workers in laying out work. Maintain efficient and continuous supervision.
- (c) Protection of Work in progress: The Contractor is to adequately protect Work completed or in progress. Work damaged or defaced due to failure in providing such protection is to be removed and replaced, or repaired, as directed by the City at no cost to the City.

Should any dispute arise regarding the quality of the workmanship, materials or products used in the performance of the Work, the final decision regarding the acceptable quality of the workmanship, and fitness of the materials and products rests strictly with the City.

Additionally, all Works required hereunder will be performed as promptly as possible, and in any event within the time stated by the City, and such Work will be subject to approval and acceptance of the City, but such approval and acceptance will not relieve the Contractor from the obligation to correct any incomplete, inaccurate or defective work, all of which shall be promptly remedied by the Contractor on demand, without cost to the City.

**END OF PAGE**

**SCHEDULE B - APPENDIX 2  
SUPPLEMENTARY SPECIFICATIONS – (PROJECT)**

<b>SUPPLEMENTARY SPECIFICATIONS (PROJECT)</b>		
<b>Section</b>	<b>Title</b>	<b>SSP</b>
<b>01 33 01</b>	<b>Project Record Documents</b>	<p><b>Add 1.9 as follows:</b></p> <p>The <i>Contractor</i> shall be responsible to submit as-built information to the <i>Contract Administrator</i> as per Article 4.2 of the Form of Agreement in the Tender. The <i>Contractor</i> shall be responsible to submit sufficient as-built information to the <i>Contract Administrator</i> prior to <i>Substantial Performance</i>.</p> <p>The <i>Contractor</i> shall provide field survey pick-up during construction and upon completion to document record information on all roadwork and utility construction. All <u>applicable</u> items must be provided to the <i>Contract Administrator</i> before Substantial Performance is granted:</p> <p>1.0 <span style="margin-left: 100px;"><u>Roadworks:</u></span></p> <p>1.1 Confirmation of all horizontal and vertical design information. Any deviation for "Issued for Construction" design is to be surveyed and/or noted to allow for updating of "As Constructed" drawing submission;</p> <p>1.2 Location and width of driveway locations to the closet lot line; and</p> <p>1.3 If there is NOT a Storm Sewer (drainage) plan, location (x,y) and rim elevation of catchbasins to be provided as part of the Roadworks As Constructed information submission.</p> <p>2.0 <span style="margin-left: 100px;"><u>Other:</u></span></p> <p>2.1 Location and elevation (x,y,z) of any significant ground features (retaining wall location and height, edge of brick decks, start and end points of guard rails, CMB's etc.);</p> <p>2.2 Street sign locations (x,y) and sign type; and</p> <p>2.3 All drawings in the "Issued for Construction" set are to be confirmed as "constructed" (i.e., planting, irrigation, retaining walls etc.). Any deviation from the original design is to be noted with adequate information to allow for drafting of "As Constructed" drawings.</p>
<b>01 33 01</b>	<b>Project Record Documents</b>	<p><b>Add 1.10 as follows:</b></p> <p>Prior to release of all deficiency holdbacks, the <i>Contractor</i> shall submit to the consultant a deficiency completion report(s), confirming that the deficiencies have been rectified, verified by photo evidence and a date completed.</p>

		After the deficiency report(s) has been submitted, the <i>Contract Administrator</i> will inspect for final acceptance.
<b>01 55 00</b>	<b>Traffic Control, Vehicle Access and Parking</b>	<b>Delete SS 1.5.1 and replace it with the following:</b>  Payment for all work performed under this Section will be on a Lump Sum basis unless noted otherwise in the Schedule of Quantities and Prices. Payment shall be 10% upon preparing TMP's, securing permits and erecting traffic control devices; 80% distributed in monthly Progress Payments for traffic control persons and related control devices; and 10% upon Substantial Performance.
<b>31 24 13</b>	<b>Roadway Excavation, Embankment and Compaction</b>	<b>Change wording to read “three classes” of excavation and add 1.3.1.3 as follows:</b>  Mass Excavation: Removal and disposal at an approved location off-site of surface concrete structures and walks, curbs, gutters, retaining walls, asphalt pavement, driveway removals, manholes, catchbasins, pipes, culverts, end-walls, and any other structures on surface or underground specifically designated, or required as shown, on the <i>Contract Drawings</i> for removal. Mass Excavation includes saw cutting of asphalt or concrete.  Asphalt removals shown on <i>Contract Drawings</i> as Surface Mill or Full Depth Mill will be paid in their respective units.
<b>31 24 13</b>	<b>Roadway Excavation, Embankment and Compaction</b>	<b>Delete SS 1.8.5.1 and SS 1.8.5.2 and replace them with the following:</b>  In all areas where volumes of excavation cannot be calculated by cross-sections, the following truck volumes will be used at the discretion of the <i>Contract Administrator</i> :  <ul style="list-style-type: none"> <li>• Tandem Dump Truck = 5.7 cubic metre</li> <li>• Trailer Pup = 4.2 cubic metre</li> <li>• Truck &amp; Transfer = 17 cubic metre</li> </ul>
<b>OPT 1</b>	<b>Work Phasing</b>	The City may allow the Contractor to complete both Phase 1 and Phase 2 at the same time as the South Surrey Arena may not be in use by the public at all times. Tenderers are to provide an adjustment price (credit) if the work would be permitted to be completed all at the same time without phasing.
<b>OPT 2</b>	<b>Thermoplastic Pavement Markings</b>	The lump sum payment item for the optional painted thermoplastic pavement marking works in the Schedule of Quantities is to provide an optional alternative approach where all pavement markings shown on Contract Drawings are

		<p>thermoplastic (i.e., no painted pavement markings) instead of painted.</p> <p>The cost for the optional work shall include all extra costs to complete the pavement markings as thermoplastic. If the thermoplastic option is approved, Items 32.10 and OPT 2 would be paid.</p>
--	--	---



**SCHEDULE B - APPENDIX 2-A  
CONTRACT DRAWINGS - (PROJECT)**

**LIST OF CONTRACT DRAWINGS**

The following Contract Drawings are included as part of this RFQ.

<b>Schedule 2: List of Contract Drawings</b>				
<b>DESCRIPTION</b>	<b>DRAWING No.</b>	<b>DATE</b>	<b>REVISION No.</b>	<b>REVISION DATE</b>
<b>SOUTH SURREY ARENA PARKING LOT REHABILITATION</b>				
Cover, Drawing Index	21-0714-C	2021-08-13	2	2022-03-08
General Notes	21-0714-N1	2021-08-13	2	2022-03-08
Site Grading	21-0714-G1	2021-08-13	2	2022-03-08
Pavement Marking	21-0714-PM1	2021-08-13	2	2022-03-08
Erosion and Sediment Control Plan Stage 1	21-0714-ESC1	2021-08-13	3	2022-03-08
Erosion and Sediment Control Plan Stage 2	21-0714-ESC1	2021-08-13	3	2022-03-08
Erosion and Sediment Control Plan Stage 3	21-0714-ESC1	2021-08-13	3	2022-03-08

**- END OF PAGE -**

# CITY OF SURREY

13450 - 104 AVENUE, SURREY, BC, CANADA V3T 1V8

# SOUTH SURREY ARENA PARKING LOT REHABILITATION ISSUED FOR QUOTATION

LEGEND					
EXISTING	PROPOSED	DESCRIPTION	EXISTING	PROPOSED	DESCRIPTION
		IRON PROPERTY PIN			WATERMAIN
		BUILDING			WATER SERVICE CONNECTION
		EDGE OF PAVEMENT			WATER VALVE
		CURB & GUTTER			AIR VALVE
		TRUCK ROUTE			HYDRANT & VALVE ASSEMBLY
		SANITARY SEWER			YARD HYDRANT
		SANITARY CONNECTION & INSPECTION CHAMBER			CAPPED END
		STORM SEWER			WATER METER
		STORM CONNECTION & INSPECTION CHAMBER			BLOW-OFF
		STORM SEWER SERVICE			UNDERGROUND TELEPHONE & MANHOLE
		FRENCH DRAIN			UNDERGROUND ELECTRICAL & MANHOLE
		STORM SEWER & CLEANOUT			GASMAIN
		CATCH BASIN - TOP INLET & SIDE INLET			TRAFFIC SIGNAL & STREET LIGHT U/G DUCTS
		LAWN DRAIN			ORNAMENTAL STREET LIGHT - DAVIT
		CATCH BASIN MANHOLE			ORNAMENTAL STREET LIGHT - POST TOP
		SWALE			UTILITY POLE
		DITCH			UTILITY POLE W/ LIGHT
		SIDEWALK (ASPHALT)			JUNCTION BOX
		SIDEWALK (CONCRETE)			GROUND ELEVATION
		RETAINING WALL			DIRECTION OF OVERLAND FLOW

DRAWING INDEX			
DRAWING TYPE	DRAWING DESCRIPTION	DWG #	SHEET #
COVER SHEET, DRAWING INDEX	SOUTH SURREY ARENA	21-0714-C1	0
GENERAL NOTES	SOUTH SURREY ARENA	21-0714-N1	1
SITE GRADING	SOUTH SURREY ARENA	21-0714-G1	2
MARKING/SIGNAGE	SOUTH SURREY ARENA	21-0714-PM1	3
EROSION AND SEDIMENT CONTROL PLAN STAGE 1	SOUTH SURREY ARENA	21-0714-ESC1	4
EROSION AND SEDIMENT CONTROL PLAN STAGE 2	SOUTH SURREY ARENA	21-0714-ESC2	5
EROSION AND SEDIMENT CONTROL PLAN STAGE 3	SOUTH SURREY ARENA	21-0714-ESC3	6



**GENERAL NOTES**

- FOR THE PURPOSE OF CONSTRUCTION AND ACCOUNTABILITY THE CONTRACTOR MUST ADVISE THE SURREY CITY INSPECTOR, IN WRITING, WHICH OF THE CITY NOTES IS GOING TO BE THE RESPONSIBILITY OF THE CONTRACTOR'S CONTRACTOR.
- CONSTRUCTION IS TO BE IN ACCORDANCE WITH THE CITY OF SURREY HIGHWAY AND TRAFFIC BYLAW NO. 13007, SUBDIVISION BYLAW NO. 8830 AND THE APPLICABLE MUNICIPAL MASTER SPECIFICATIONS AND STANDARD DETAIL DRAWINGS, CITY OF SURREY STANDARD CONSTRUCTION DOCUMENTS, SUPPLEMENTARY SPECIFICATIONS & STANDARD DRAWINGS AND CITY DESIGN CRITERIA.
- TRAFFIC CONTROL IS THE RESPONSIBILITY OF THE CONTRACTOR AND THE CONTRACTOR SHALL COMPLY WITH SECTION 52 OF THE INDUSTRIAL HEALTH AND SAFETY REGULATIONS OF THE WORKERS' COMPENSATION BOARD OF B.C. AND THE INSTRUCTIONS OUTLINED ON THE CITY ROAD AND RIGHT-OF-WAY PERMIT AND TRAFFIC OBSTRUCTION PERMIT ISSUED BY THE CITY.  
THE CONTRACTOR IS TO HAVE, ON SITE, A COPY OF THE CURRENT "B.C. TRAFFIC CONTROL MANUAL FOR WORK ON ROADWAYS" AS PUBLISHED BY THE MINISTRY OF TRANSPORTATION AND INFRASTRUCTURE.
- THE CONTRACTOR SHALL BE RESPONSIBLE FOR OBTAINING ALL CITY PERMITS FOR WORK WITHIN THE CITY ROAD ALLOWANCE.
- WHERE UTILITY OR SERVICE CROSSINGS ARE REQUIRED ACROSS EXISTING PAVEMENTS, AN UNDERGROUND METHOD OF INSTALLATION IS REQUIRED UNLESS SPECIAL APPROVAL IS GIVEN FROM THE CITY FOR AN OPEN CUT OPERATION. ALL EXISTING PAVEMENTS, BOULEVARDS, DRIVEWAYS, ETC., ARE TO BE REINSTATED TO ORIGINAL OR BETTER CONDITION AND IN ACCORDANCE WITH CITY SPECIFICATIONS AND THE PAVEMENT CUT POLICY.
- SURREY'S ISA MONUMENT(S) ARE TO BE PROTECTED AND SHOULD THEY REQUIRE RAISING OR RELOCATING, THE CONTRACTOR WILL NOTIFY SURREY'S SURVEY DEPARTMENT AT LEAST THREE WORKING DAYS IN ADVANCE OF SCHEDULING WORK AFFECTING THEM. AN ISA MONUMENT SHALL BE CONSIDERED TO BE DISTURBED OR DESTROYED, BY THE CONTRACTOR, IF THE CONSTRUCTION FOR THE PROJECT:
  - LOWERS THE GRADE OF THE ROAD AT THE LOCATION OF AN ISA MONUMENT(S),
  - RAISES THE GRADE OF THE ROAD AT THE LOCATION OF AN ISA MONUMENT(S), OR
  - INSTALLS ANY UNDERGROUND UTILITIES (INCLUDING BC GAS, BC HYDRO, BC TELEPHONE, GVRD WATER/SANITARY SEWER OR DRAINAGE ETC.) WITHIN 1.500 METRE RADIUS OF THE ISA MONUMENT(S).  
THE CITY WILL INVOICE THE CONTRACTOR A NON REFUNDABLE FLAT RATE FEE OF \$1,890.00 FOR EACH ISA MONUMENT DISTURBED OR DESTROYED.
- ALL STREET, TRAFFIC, AND ADVISORY SIGNS, PAVEMENT MARKINGS AND NO-POST GUARDRAILS REQUIRED BUT NOT NECESSARILY SHOWN ON THE DRAWINGS, SHALL BE INSTALLED BY THE CITY AT THE CONTRACTOR'S COST.
- WHERE INFILLING OF EXISTING DITCHES IS REQUIRED OR WHERE SERVICES ARE CONSTRUCTED IN A FILL SECTION, FILL MATERIAL IS TO BE IN ACCORDANCE WITH CITY SPECIFICATIONS AND IS TO BE COMPACTED TO 95% OF MODIFIED PROCTOR DENSITY.
- DRIVEWAY BOULEVARD CROSSINGS TO EACH OF THE PROPOSED LOTS ARE TO BE INSTALLED IN ACCORDANCE WITH THE CITY STANDARD DRAWINGS.
- RESIDENTS DIRECTLY AFFECTED BY CONSTRUCTION OF THIS PROJECT MUST BE GIVEN 48 HOURS WRITTEN NOTICE OF THE PROPOSED START OF CONSTRUCTION.  
THE CONTRACTOR WILL REQUIRE WRITTEN AUTHORIZATION FROM A PRIVATE PROPERTY OWNER, WITH A COPY TO THE CITY, PRIOR TO ANY ENTRY ONTO PRIVATE PROPERTY AND A WRITTEN RELEASE, FROM THE PROPERTY OWNER, WHEN COMPLETED.
- WHEN NATIVE SITE GRANULAR BACKFILL IS PROPOSED FOR USE IN TRENCHES THE CONTRACTOR SHALL EMPLOY A PROFESSIONAL ENGINEER WITH EXPERIENCE IN GEOTECHNICAL ENGINEERING FOR PERFORMANCE OF IN PLACE DENSITY AND SIEVE TESTING. SELECTION OF THE PROFESSIONAL ENGINEER AND USE OF THE SITE MATERIAL IS TO BE APPROVED BY THE CITY. THE SITE MATERIAL MUST FALL WITHIN ONE OF THE GRANULAR BACKFILL MATERIAL SPECIFICATIONS. RIVER SAND IS NOT ACCEPTABLE AS TRENCH BACKFILL MATERIAL.
- THE CONTRACTOR SHALL FACILITATE AND SUPPLY ALL NECESSARY SAFETY EQUIPMENT REQUIRED UNDER THE WCB REGULATIONS FOR THE CITY OR ITS REPRESENTATIVES OR THE ENGINEER OF RECORD TO INSPECT THE SANITARY SEWER AND STORM SEWER SYSTEMS. THE EQUIPMENT SHALL BE SUPPLIED UNTIL SUCH TIME AS A CERTIFICATE OF COMPLETION IS ISSUED BY THE CITY.

- CONTRACTOR IS TO VERIFY THE LOCATION AND ELEVATION OF ALL PIPES, OR OTHER UTILITY CROSSINGS, PRIOR TO CONSTRUCTION AND SHALL NOTIFY THE ENGINEER OF RECORD OF ANY CONFLICTS.
- THE "SURREY TREE PROTECTION BYLAW, 2006 NO. 16100" REQUIRES THAT A CUTTING PERMIT BE OBTAINED BEFORE ANY TREES ARE REMOVED FROM THE SITE. OTHER PROVISIONS OF THE BYLAW MAY ALSO BE APPLICABLE.

**CITY STANDARD ROADWORK**

- EXISTING VALVE BOXES, MANHOLES, ETC. WITHIN THE ROAD ALLOWANCE MUST BE ADJUSTED TO SUIT THE PROPOSED FINISHED GRADE.
- ALL LOOSE, ORGANIC, OTHERWISE DELETERIOUS MATERIALS OR SOFT SPOT(S) ARE TO BE EXCAVATED AND REMOVED FROM THE ROADWAY AND UTILITY TRENCHES IN THE ROADWAY AS DIRECTED BY THE CONTRACT ADMINISTRATOR OR THE CITY.

**CITY STORM SEWER NOTES**

- ALL SERVICE CONNECTIONS SHALL BE MADE TO THE MAIN WHEREVER POSSIBLE. SHOULD A CONNECTION HAVE TO BE MADE TO A MANHOLE, THE CONNECTION INVERT SHALL BE AT THE SAME ELEVATION AS THE CROWN OF THE HIGHEST SEWER MAIN.
- ALL MANHOLES ARE TO BE A MINIMUM OF 1050mm DIAMETER UNLESS OTHERWISE NOTED.
- ALL STORM SEWER SERVICE CONNECTIONS ARE TO BE A MINIMUM 150mm DIAMETER, UNLESS OTHERWISE NOTED.
- ALL GRANULAR PIPE BEDDING SHALL BE EITHER TYPE 1 OR TYPE 2 ONLY AS PER THE CITY SPECIFICATIONS.
- MR10 OR METER BOX IS REQUIRED WHEN STORM INSPECTION CHAMBERS ARE LOCATED WITHIN THE TRAVELED AREA OR 2.0m OF THE DRIVEWAY AS PER SSD-G.1.1 (TYP.)
- TESTING TO BE COMPLETED TO LATEST CITY OF SURREY AND MMCD SPECIFICATIONS AT THE CONTRACTORS EXPENSE.

**PARKS/CITY TREE NOTES:**

- PARKS TO BE INVITED TO PRE-CONSTRUCTION MEETING. CONTACT PARKS DEVELOPMENT INSPECTOR AT 604 501 5166 TO MAKE THE NECESSARY ARRANGEMENTS.
- PRIOR TO LAND CLEARING, TREE BARRIERS (SSD-PK5005) ARE REQUIRED FOR ALL EXISTING AND ANY FUTURE CITY TREES. BARRIERS MUST BE INSPECTED AND APPROVED PRIOR TO WORKS IN THOSE AREAS COMMENCING. BARRIERS TO BE MAINTAINED UNTIL ALL WORKS IN THE AREA ARE COMPLETE.
- NO CUTS OR FILL PERMITTED IN THE CRITICAL ROOT ZONE OF RETAINED TREES, WITHOUT PRE-APPROVAL BY PARKS.
- NO TREES, PARTS OF TREES OR VEGETATION ARE TO BE REMOVED FROM FUTURE OR EXISTING PARKLAND WITHOUT PRE-APPROVAL BY PARKS.
- SUPERVISION BY A CONSULTING ARBORIST APPROVED BY THE CITY OF SURREY, SUPPLIED BY CONTRACTOR, WILL BE REQUIRED DURING ANY ACTIVITIES IN CLOSE PROXIMITY TO THE TPZ OF CITY TREES. FOLLOW UP REPORTS/ARBORIST SIGN OFF REQUIRED FOR ANY ARBORIST SUPERVISED ACTIVITIES AND ARE TO BE SENT TO PARKS AND ENGINEERING.
- CONSULTING ARBORIST SUPPLIED BY THE CONTRACTOR TO PROVIDE COMFORT LETTER AND REPORT COMPLETE WITH PHOTOGRAPHS PRIOR TO CONSTRUCTION.
- ANY PRUNING REQUIRED TO RETAIN TREES, TO OPEN SIGHTLINES, PROVIDE CLEARANCE FOR MACHINES OR EQUIPMENT, REMOVAL OF HAZARDOUS LIMBS ETC., WILL BE DONE AT THE CONTRACTOR'S EXPENSE UNDER THE GUIDANCE OF PARKS BY AN ISA CERTIFIED ARBORIST.
- ENSURE ALL CITY TREES ARE PROTECTED AND RESPECTED DURING CONSTRUCTION - NO STORAGE OF EQUIPMENT, MATERIALS, SPOIL, VEHICLES ETC. IS PERMITTED WITHIN 3m OF ANY CITY TREE.
- SUPERVISION BY A QUALIFIED ENVIRONMENTAL PROFESSIONAL IS REQUIRED FOR WORKS WITHIN THE RIPARIAN SETBACK.
- PARKS TO INSPECT RETAINED CITY TREES AND PARKLAND WITH LAND DEVELOPMENT'S FINAL INSPECTIONS.

**ENGINEER'S CERTIFICATION**

I, JON BRIDLE, PROFESSIONAL ENGINEER, IN GOOD STANDING IN AND FOR THE PROVINCE OF BRITISH COLUMBIA, HEREBY CERTIFY THAT THE WORKS AS HEREIN SET OUT ON THE ATTACHED DRAWINGS HAVE BEEN DESIGNED TO GOOD ENGINEERING STANDARDS AND IN ACCORDANCE WITH THE LATEST EDITION OF THE CITY OF SURREY DESIGN CRITERIA MANUAL, THE MASTER MUNICIPAL CONSTRUCTION DOCUMENTS (MMCD), AND THE CITY OF SURREY STANDARD CONSTRUCTION DOCUMENTS (GENERAL CONDITIONS, SUPPLEMENTARY SPECIFICATIONS AND SUPPLEMENTARY STANDARD DRAWINGS) ADOPTED BY THE CITY OF SURREY.

EXCEPTIONS:

2022/03/11

DATE

SIGNATURE

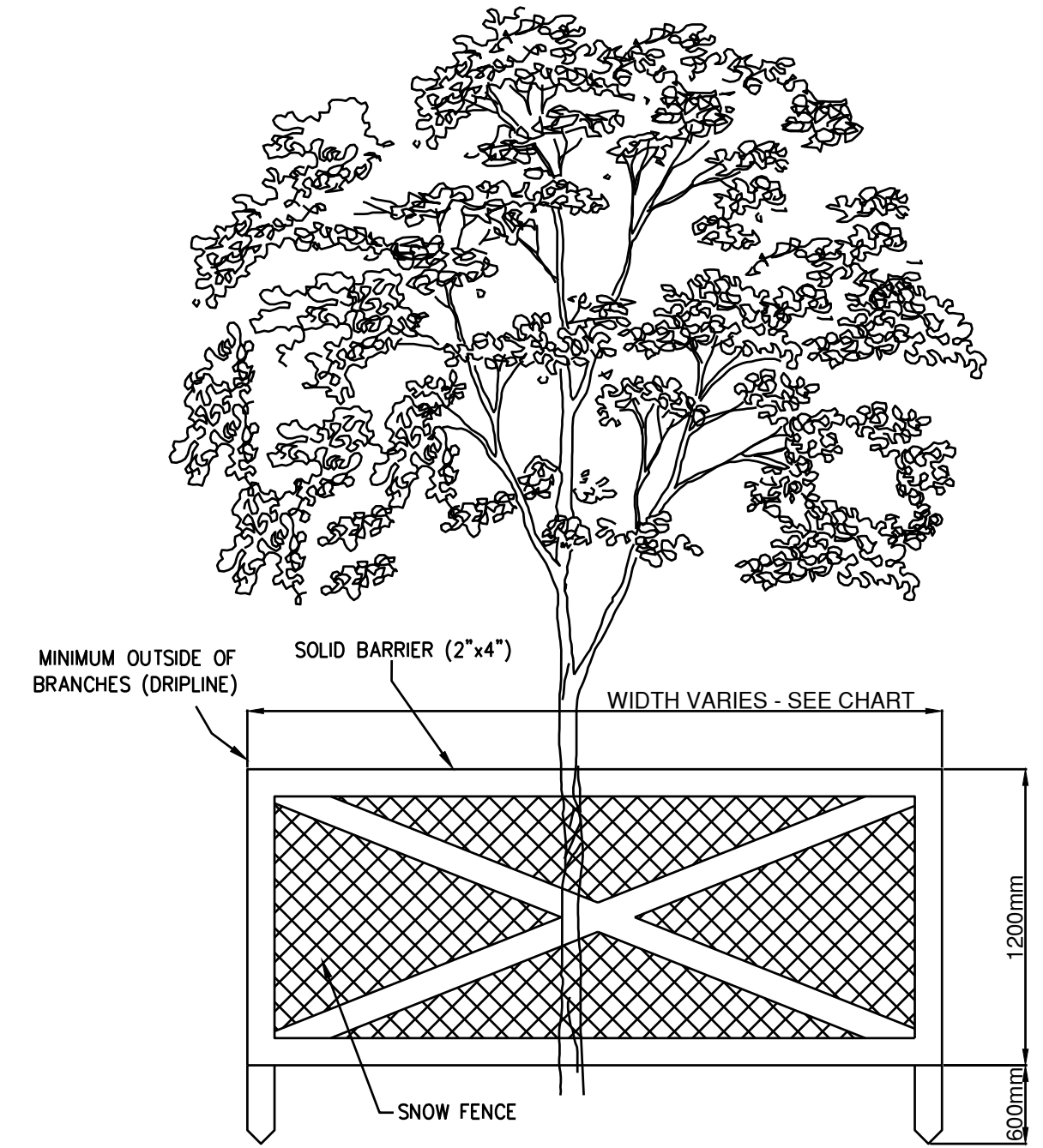

**TREE PROTECTION FENCING DETAIL**  
N.T.S.

MINIMUM PROTECTION REQUIRED AROUND TREE		
TRUNK DIAMETER (DBH)	DISTANCE FROM TRUNK	TOTAL DIAMETER
20cm/8in	1.2m	2.6m
25cm/10in	1.5m	3.25m
30cm/12in	1.8m	3.9m
35cm/14in	2.1m	4.55m
40cm/16in	2.4m	5.2m
45cm/18in	2.7m	5.85m
50cm/20in	3.0m	6.5m
55cm/22in	3.3m	7.15m
60cm/24in	3.6m	7.8m
75cm/30in	4.5m	9.75m
90cm/36in	5.0m	10.9m
100cm/40in	6.0m	13.0m

NOTES:

- A PROTECTIVE BARRIER MUST BE INSTALLED AROUND EVERY TREE TO BE RETAINED PRIOR TO THE WORK COMMENCING ONSITE, AND THAT BARRIER MUST REMAIN INTACT UNTIL THE DIRECTOR HAS AUTHORIZED ITS REMOVAL.
- THE PROTECTIVE BARRIER MUST BE CONSTRUCTED OF SNOW FENCE FASTENED SECURELY TO A STURDY WOODEN FRAME OR PLYWOOD.
- ANY EXCAVATION ADJACENT TO THE PROTECTIVE BARRIER MUST BE DONE BY HAND.
- MAINTENANCE OF TREES THAT ARE TO REMAIN MUST INCLUDE WATERING BUT WILL NOT INCLUDE ANY CUTTING OR PRUNING OF BRANCHES OR ROOTS UNLESS APPROVED BY THE DIRECTOR.
- NO DUMPING OR STOCKPILING WITHIN TREE PROTECTION BARRIER.
- INSPECT BARRIER WEEKLY AND REPAIR AS NEEDED.

**ISSUED FOR QUOTATION**

REV.	DATE	DESCRIPTION	BY
2	2022.03.08	ISSUED FOR QUOTATION	JEB
1	2021.09.21	ISSUED FOR REVIEW	JEB

"BY SEALING AND SIGNING THIS DRAWING, I CERTIFY THAT THE INFORMATION CONTAINED IN THESE DRAWINGS ACCURATELY REFLECTS THE ORIGINAL DESIGN, ADDENDA, CHANGE ORDERS AND MATERIAL DESIGN CHANGES MADE DURING CONSTRUCTION AND FIELD REVIEWED BY ME, OR MY REPRESENTATIVE, AND THAT THE AS-CONSTRUCTED WORKS SUBSTANTIALLY COMPLY WITH THE ORIGINAL DESIGN INTENT. HOWEVER, I DO NOT ACCEPT RESPONSIBILITY FOR THE ACCURACY OR COMPLETENESS OF THE AS-CONSTRUCTED INFORMATION SUPPLIED BY OTHERS CONTAINED IN THESE DRAWINGS."

CONSULTANT

**R.F. BINNIE & ASSOCIATES LTD.**  
314-9440 202 Street  
Langley, BC V1M 4A6  
TEL 604 574 3336  
BINNIE.com

CLIENT

**CITY OF SURREY**  
13450 - 104 AVENUE, SURREY, BC, CANADA V3T 1V8

**SOUTH SURREY ARENA**  
GENERAL NOTES  
PLAN

SEAL

SCALE	DATE (YYYY.MM.DD)
NOT TO SCALE	2021-08-13
DESIGNED	CONSULTANT PROJ. NO.
JEB	21-0714
DRAWN	DWG. NO.
SV	N1
REVIEWED	REV. NO.
KN	2

SURREY PROJECT NUMBER	DRAWING TYPE
	<b>GENERAL NOTES</b>
SHEET 1 OF 6	



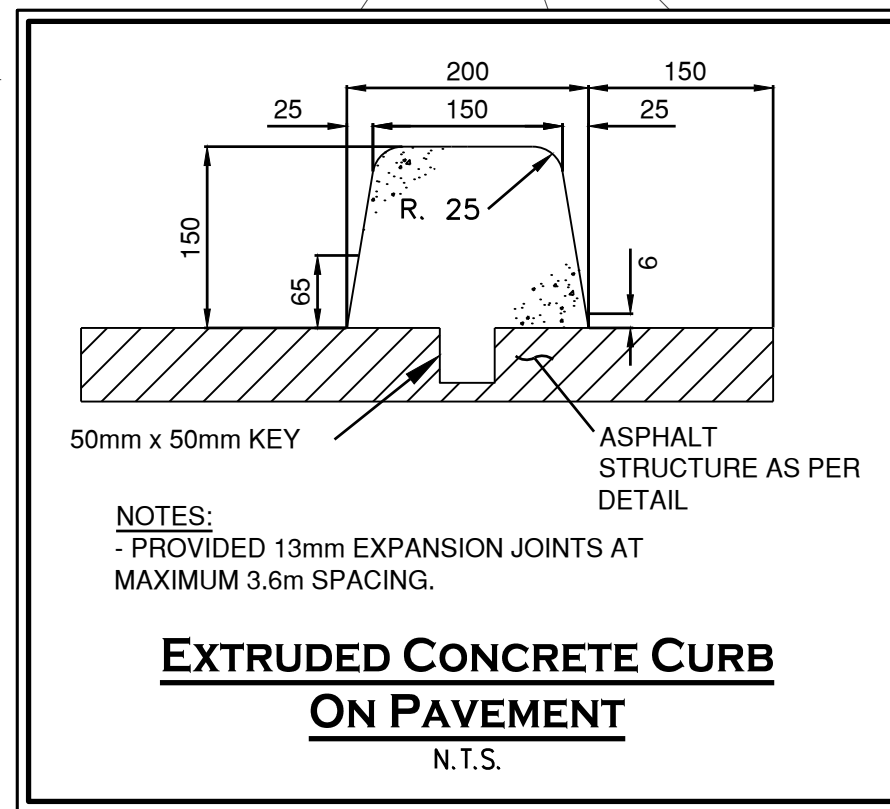
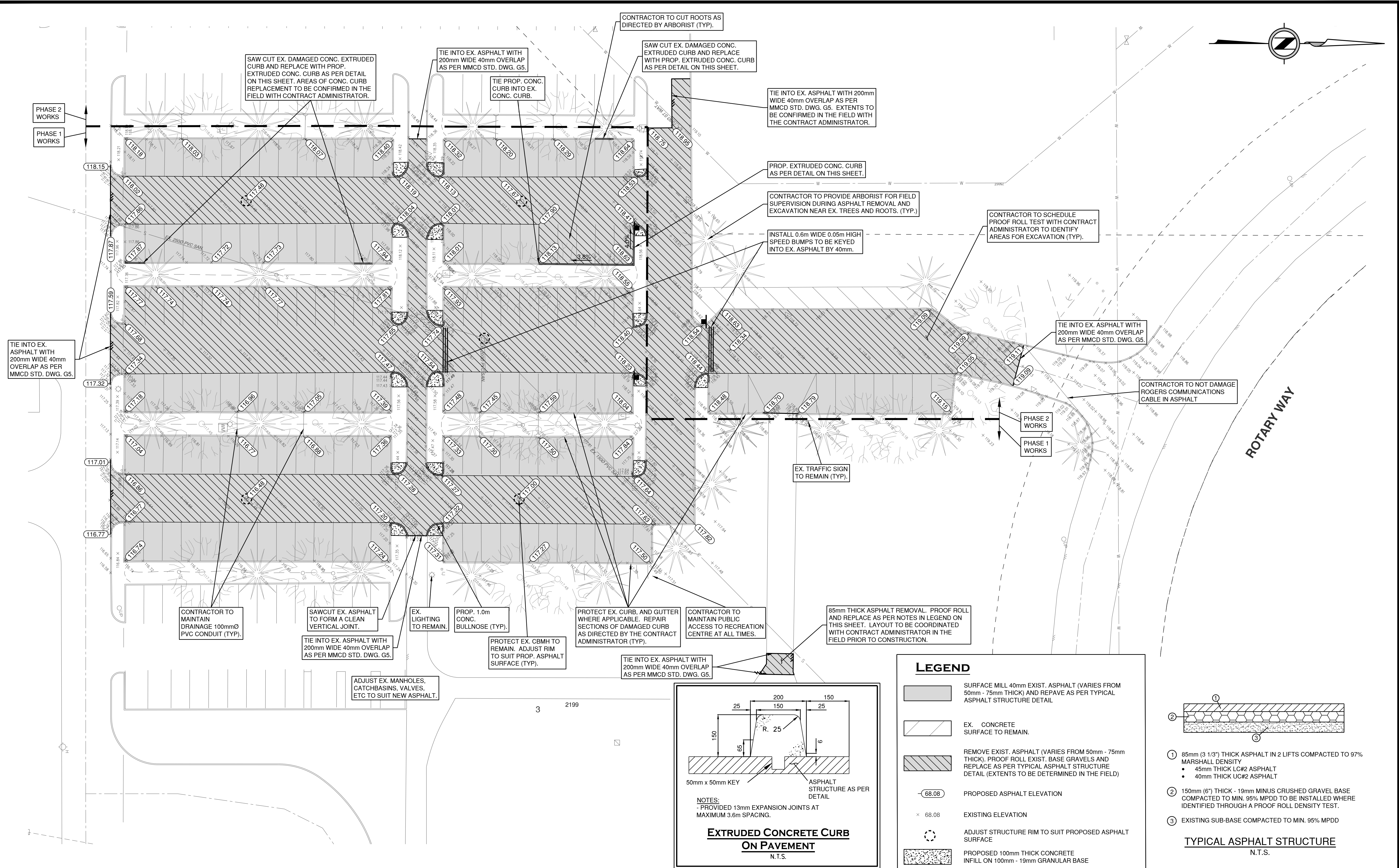
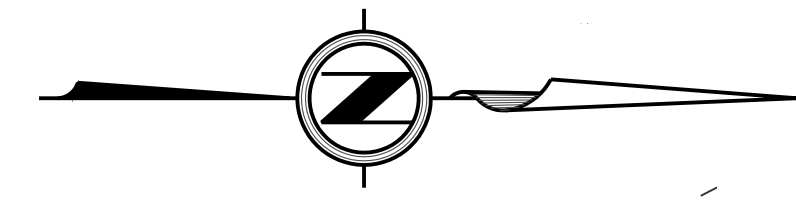

**LEGEND**

	SURFACE MILL 40mm EXIST. ASPHALT (VARIES FROM 50mm - 75mm THICK) AND REPAVE AS PER TYPICAL ASPHALT STRUCTURE DETAIL
	EX. CONCRETE SURFACE TO REMAIN.
	REMOVE EXIST. ASPHALT (VARIES FROM 50mm - 75mm THICK). PROOF ROLL EXIST. BASE GRAVELS AND REPLACE AS PER TYPICAL ASPHALT STRUCTURE DETAIL (EXTENTS TO BE DETERMINED IN THE FIELD)
- 68.08	PROPOSED ASPHALT ELEVATION
x 68.08	EXISTING ELEVATION
	ADJUST STRUCTURE RIM TO SUIT PROPOSED ASPHALT SURFACE
	PROPOSED 100mm THICK CONCRETE INFILL ON 100mm - 19mm GRANULAR BASE

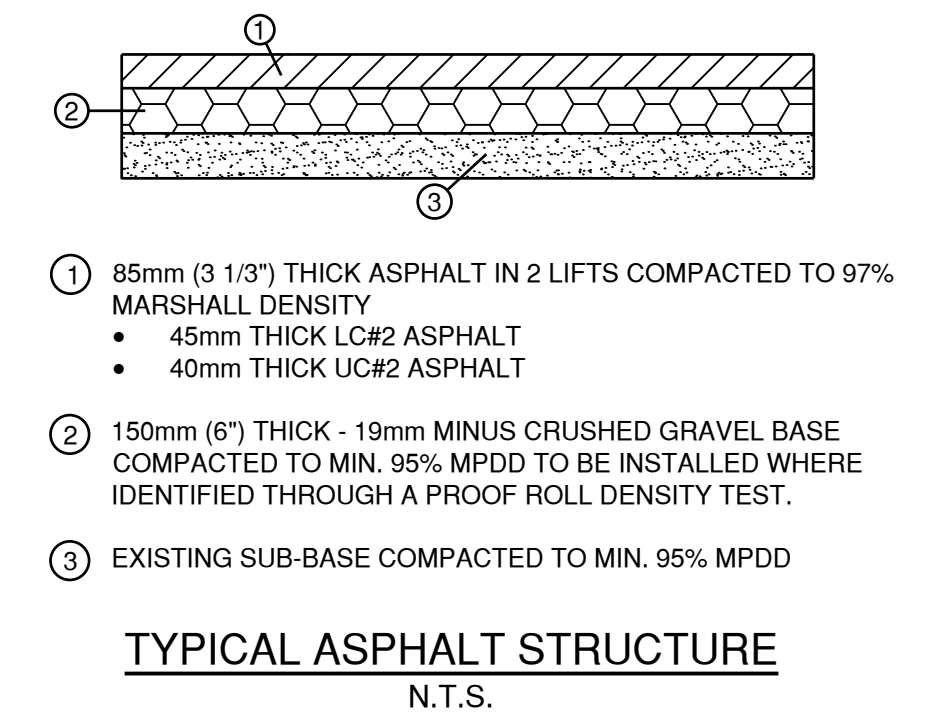

**ISSUED FOR QUOTATION**

**LEGAL DESCRIPTION**

SURVEY BENCHMARK MON: 92H0852 N: 5433925.444 E: 513937.358 SCALE FACTOR: 0.9996 ELEV: 108.412

REV.	DATE	DESCRIPTION	BY
1	2021.09.21	ISSUED FOR REVIEW	JEB
2	2022.03.08	ISSUED FOR QUOTATION	JEB

"BY SEALING AND SIGNING THIS DRAWING, I CERTIFY THAT THE INFORMATION CONTAINED IN THESE DRAWINGS ACCURATELY REFLECTS THE ORIGINAL DESIGN, ADDENDA, CHANGE ORDERS AND MATERIAL DESIGN CHANGES MADE DURING CONSTRUCTION AND FIELD REVIEWED BY ME, OR MY REPRESENTATIVE, AND THAT THE AS-CONSTRUCTED WORKS SUBSTANTIALLY COMPLY WITH THE ORIGINAL DESIGN INTENT. HOWEVER, I DO NOT ACCEPT RESPONSIBILITY FOR THE ACCURACY OR COMPLETENESS OF THE AS-CONSTRUCTED INFORMATION SUPPLIED BY OTHERS CONTAINED IN THESE DRAWINGS."

**CONSULTANT**

**BINNIE**  
The people behind your infrastructure.

R.F. BINNIE & ASSOCIATES LTD.  
314-9440 202 Street  
Langley, BC V1M 4A6  
TEL: 604 574 3336  
BINNIE.com

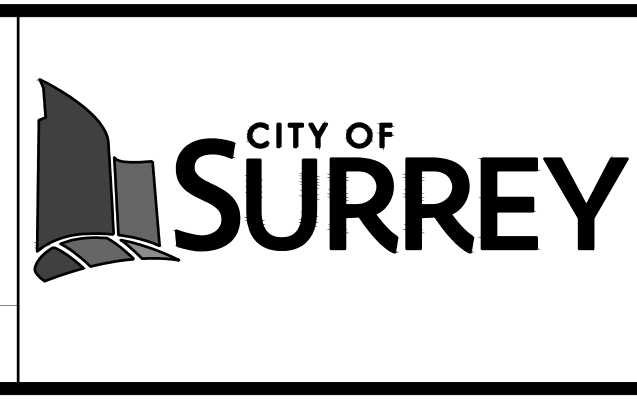

**CLIENT**

**CITY OF SURREY**  
13450 - 104 AVENUE, SURREY, BC, CANADA V3T 1V8

**SOUTH SURREY ARENA**  
SITE GRADING  
PLAN

**SCALE**  
0 1:250 10m

**DATE** (YYYY.MM.DD)  
2021-08-13

**DESIGNED** JEB  
**DRAWN** SV  
**REVIEWED** KN

**CONSULTANT PROJ. NO.**  
21-0714

**DWG. NO.**  
G1

**REV.**  
2

**SURREY PROJECT NUMBER**

**DRAWING TYPE**  
**GRADING**

**SHEET 2 OF 6**



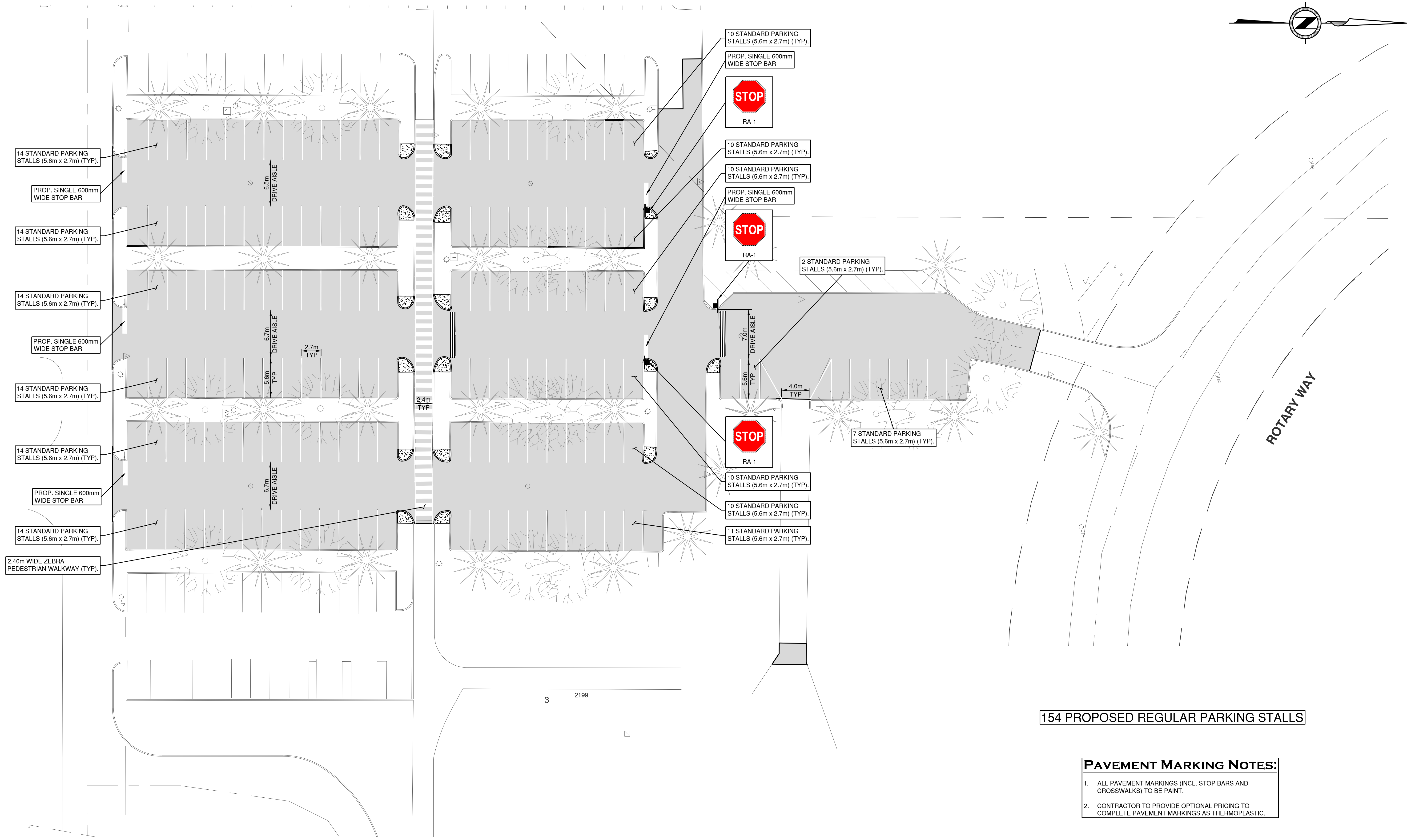
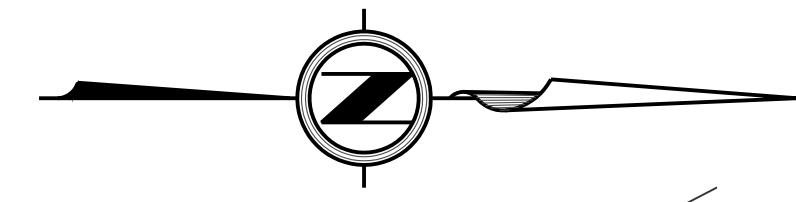

**PAVEMENT MARKING NOTES:**

- ALL PAVEMENT MARKINGS (INCL. STOP BARS AND CROSSWALKS) TO BE PAINT.
- CONTRACTOR TO PROVIDE OPTIONAL PRICING TO COMPLETE PAVEMENT MARKINGS AS THERMOPLASTIC.

**ISSUED FOR QUOTATION**

REV.	DATE	DESCRIPTION	BY
1	2021-09-21	ISSUED FOR REVIEW	JEB
2	2022-03-08	ISSUED FOR QUOTATION	JEB

"BY SEALING AND SIGNING THIS DRAWING, I CERTIFY THAT THE INFORMATION CONTAINED IN THESE DRAWINGS ACCURATELY REFLECTS THE ORIGINAL DESIGN, ADDENDA, CHANGE ORDERS AND MATERIAL DESIGN CHANGES MADE DURING CONSTRUCTION AND FIELD REVIEWED BY ME, OR MY REPRESENTATIVE, AND THAT THE AS-CONSTRUCTED WORKS SUBSTANTIALLY COMPLY WITH THE ORIGINAL DESIGN INTENT. HOWEVER, I DO NOT ACCEPT RESPONSIBILITY FOR THE ACCURACY OR COMPLETENESS OF THE AS-CONSTRUCTED INFORMATION SUPPLIED BY OTHERS CONTAINED IN THESE DRAWINGS."

CONSULTANT

**BINNIE**  
The people behind your infrastructure.

R.F. BINNIE & ASSOCIATES LTD.  
314-9440 202 Street  
Langley, BC V1M 4A6  
TEL 604 574 3336  
BINNIE.com

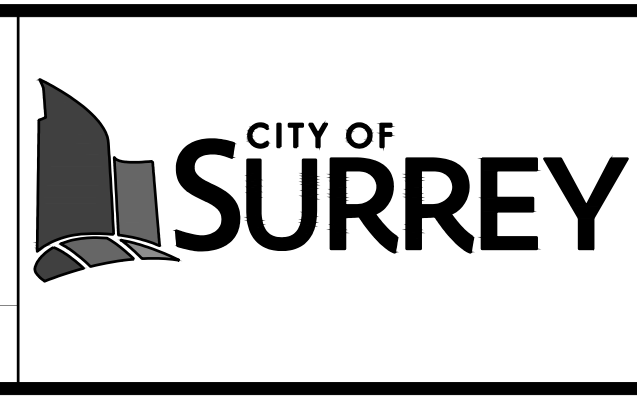

CLIENT

**CITY OF SURREY**  
13450 - 104 AVENUE, SURREY, BC, CANADA V3T 1V8

**SOUTH SURREY ARENA**  
MARKING/SIGNAGE  
PLAN

SCALE	DATE (YYYY.MM.DD)	SURREY PROJECT NUMBER
0 1:250 10m	2021-08-13	
DESIGNED JEB	CONSULTANT PROJ. NO. 21-0714	DRAWING TYPE MARKING/SIGNAGE
DRAWN SV	DWG. NO.	REV. 2
REVIEWED KN	<b>PM1</b>	SHEET 3 OF 6



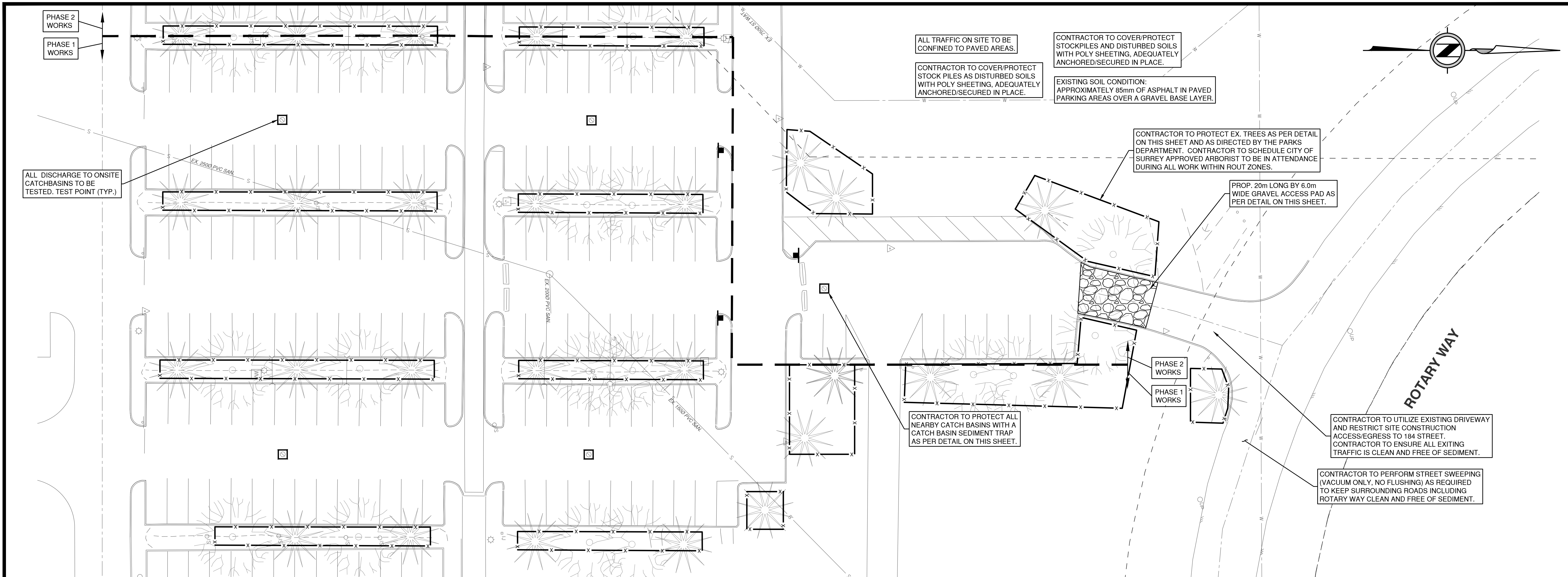

**CLEARING, ROAD STRIPPING, MILLING, PROOF ROLLING, AND BASE REMOVAL STAGE**

1. DEVELOPER TO NOTIFY BOTH THE ENGINEER OF RECORD AND THE ESC SUPERVISOR THAT CLEARING AND GRUBBING HAS COMMENCED. DEVELOPER TO PROVIDE THE CLEARING AND GRUBBING CONTRACTOR WITH A COPY OF THE ESC PERMIT AND TREE CUTTING PERMIT, INCLUDING DRAWINGS.
2. SITE CLEARING AND GRUBBING CONTRACTOR TO CONFIRM ESC PERMIT HAS BEEN ISSUED, THERE IS A COPY ON SITE, AND THE PERMIT SIGNAGE IS ERECTED AT THE SITE ENTRANCE.
3. PERIMETER ESC MEASURES TO BE INSTALLED PRIOR TO INITIATING ONSITE CLEARING AND GRUBBING.
4. INSTALL PROTECTIVE MEASURES AT OR WITHIN EXISTING CATCH/LAWN BASINS AS APPLICABLE.
5. INSTALL SPECIFIED ESC ACCESS FACILITIES/MEASURES AT ENTRY/EXIT POINTS. ALL VEHICLE MOVEMENT TO AND FROM THE SITE IS TO BE RESTRICTED TO CONTROLLED ENTRY/EXIT POINTS.
6. PRIOR TO LEAVING THE SITE, ON-SITE CLEARING AND GRUBBING CONTRACTOR TO OBTAIN SIGN OFF BY THE ESC SUPERVISOR.
7. DEVELOPER WILL BE RESPONSIBLE TO PROVIDE A COPY OF THE ESC PLAN AND PERMIT TO THE GENERAL CONTRACTOR.
8. GENERAL CONTRACTOR TO HAVE A COPY OF THE ESC PLAN AND PERMIT ONSITE AT ALL TIMES, AND ENSURE ESC SIGNAGE IS IN PLACE.
9. ONSITE STORM WATER CONTROL FACILITIES COMPLETE WITH VELOCITY CONTROL MEASURES TO BE INSTALLED AS ROADWAYS ARE STRIPPED.
10. ANY STOCKPILED MATERIAL TO BE COVERED AND ENCIRCLED BY SEDIMENT FENCE.
11. THE ENGINEER OF RECORD/ESC SUPERVISOR WILL BE RESPONSIBLE TO ENSURE THAT THE EXISTING ROADS ARE REVIEWED DAILY AND SWEEPED REGULARLY. FLUSHING OF ROADWAYS IS PROHIBITED.
12. AFTER ROUGH LOT GRADING IS COMPLETED ALL DISTURBED AREAS ARE TO BE COVERED WITH POLY OR APPROVED EQUIVALENT
13. UPON THE COMMENCEMENT OF WORKS, ESC SUPERVISOR TO CONDUCT MONITORING AS PER THE ESTABLISHED MONITORING AND REPORTING REQUIREMENTS.
14. ANY FILL USED ONSITE MUST BE INERT MATERIAL, FREE OF CONTAMINANTS, INVASIVES, OR ANY OTHER SUBSTANCES DELETERIOUS TO AQUATIC LIFE

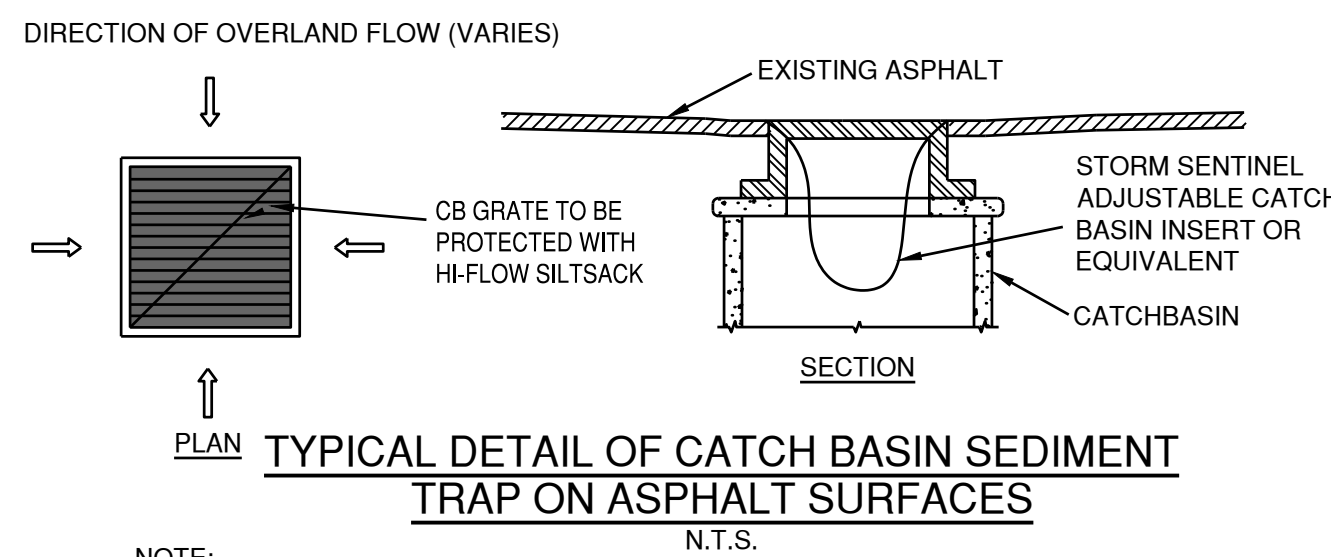

NOTE:

1. SILT SACK TO BE STORM SENTINEL ADJUSTABLE CATCH BASIN INSERT OR EQUIVALENT.
2. INSPECT SILTSACK SEDIMENT TRAP WEEKLY AND/OR AFTER EVERY MAJOR STORM EVENT
3. CATCH BASIN PROTECTION TO BE EMPTIED AND CLEANED OUT WHEN SEDIMENT SACK IS 1/2 FULL.
4. INSPECT SILTSACK DURING LOW TEMPERATURE AND/OR SNOW FREEZING CONDITIONS.

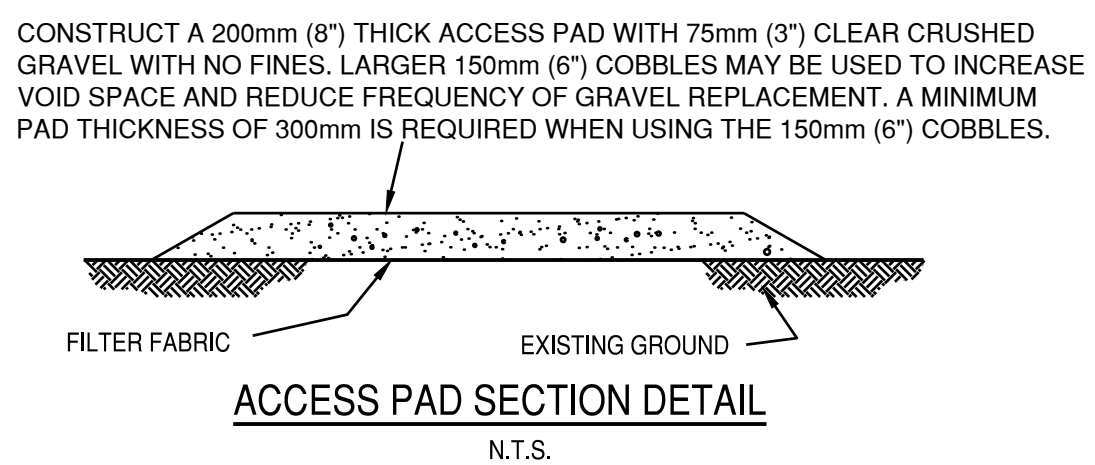

MINIMUM PROTECTION REQUIRED AROUND TREE		
TRUNK DIAMETER (DBH)	DISTANCE FROM TRUNK	TOTAL DIAMETER
20cm/8in	1.2m	2.6m
25cm/10in	1.5m	3.25m
30cm/12in	1.8m	3.9m
35cm/14in	2.1m	4.55m
40cm/16in	2.4m	5.2m
45cm/18in	2.7m	5.85m
50cm/20in	3.0m	6.5m
55cm/22in	3.3m	7.15m
60cm/24in	3.6m	7.75m
75cm/30in	4.5m	10.9m
90cm/36in	5.0m	13.0m
100cm/40in	6.0m	

NOTES:

1. A PROTECTIVE BARRIER MUST BE INSTALLED AROUND EVERY TREE TO BE RETAINED PRIOR TO THE WORK COMMENCING ONSITE, AND THAT BARRIER MUST REMAIN INTACT UNTIL THE DIRECTOR HAS AUTHORIZED ITS REMOVAL.
2. THE PROTECTIVE BARRIER MUST BE CONSTRUCTED OF SNOW FENCE FASTENED SECURELY TO A STURDY WOODEN FRAME OR PLYWOOD.
3. ANY EXCAVATION ADJACENT TO THE PROTECTIVE BARRIER MUST BE DONE BY HAND.
4. MAINTENANCE OF TREES THAT ARE TO REMAIN MUST INCLUDE WATERING BUT WILL NOT INCLUDE ANY CUTTING OR PRUNING OF BRANCHES OR ROOTS UNLESS APPROVED BY THE DIRECTOR.
5. NO DUMPING OR STOCKPILING WITHIN TREE PROTECTION BARRIER.
6. INSPECT BARRIER WEEKLY AND REPAIR AS NEEDED.

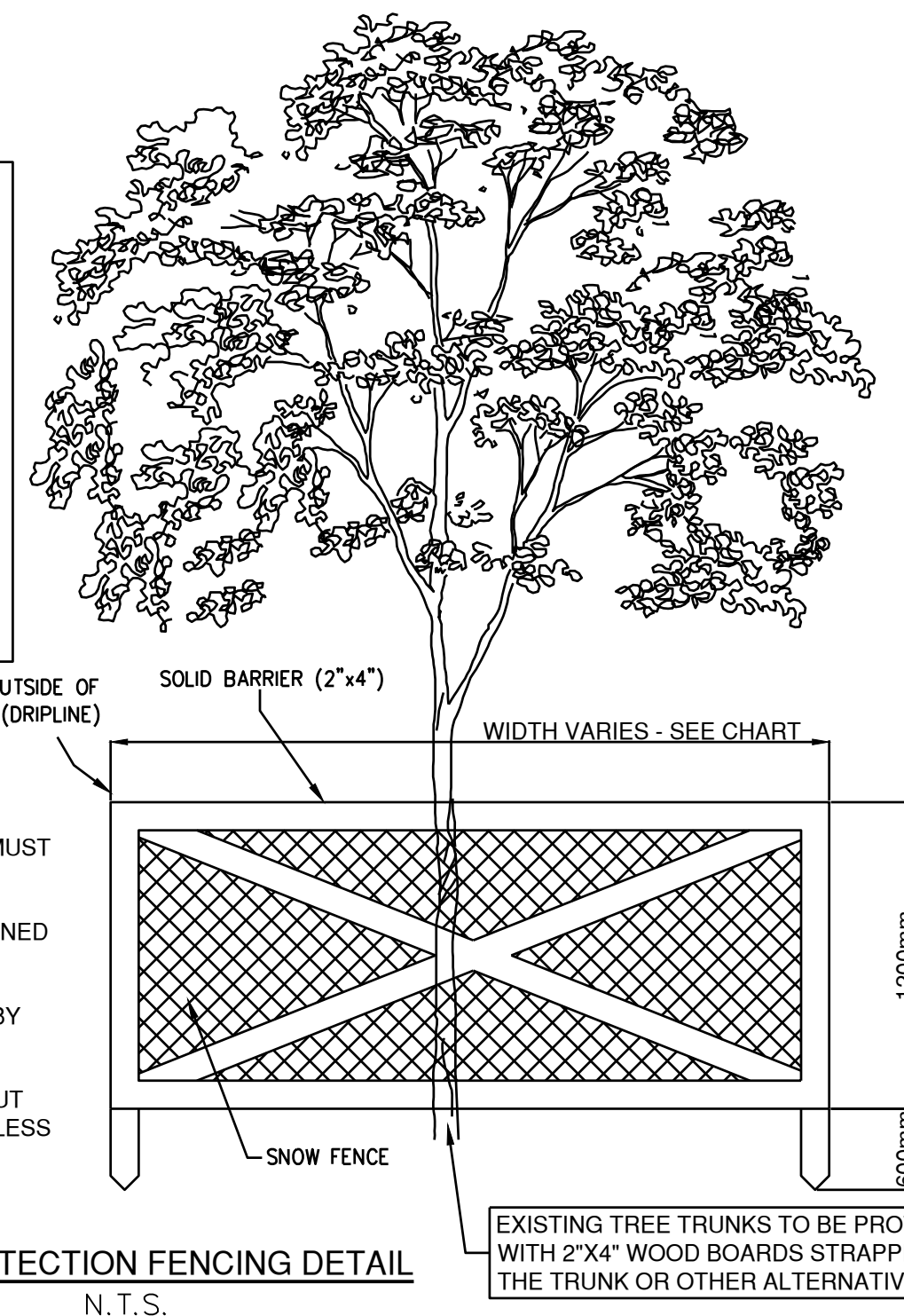

LEGEND		
EXISTING	PROPOSED	DESCRIPTION
IPF		IRON PROPERTY PIN
		BUILDING
		EDGE OF PAVEMENT
		CURB & GUTTER
D	D	STORM SEWER
		STORM CONNECTION & INSPECTION CHAMBER
		STORM SEWER SERVICE
FD	FD	FRENCH DRAIN
CO	CO	STORM SEWER & CLEANOUT
		CATCH BASIN - TOP INLET & SIDE INLET
		LAWN DRAIN
		CATCH BASIN MANHOLE
		SWALE
		DITCH
9.270		GROUND ELEVATION
		DIRECTION OF OVERLAND FLOW
		SILT FENCE
		GRAVEL PAD
		TREATMENT SYSTEM
		SEDIMENT TRAP

**ISSUED FOR QUOTATION**

LEGAL DESCRIPTION		SURVEY BENCHMARK MON: 92H0852 N: 5433925.444 E: 513937.358 SCALE FACTOR: 0.9996 ELEV: 108.412	
REV.	DATE	DESCRIPTION	BY
3	2022.03.08	ISSUED FOR QUOTATION	JEB
2	2021.12.22	RE-ASSIGNED FOR ESC PERMIT	JEB
1	2021.09.20	ISSUED FOR ESC PERMIT	JEB

"BY SEALING AND SIGNING THIS DRAWING, I CERTIFY THAT THE INFORMATION CONTAINED IN THESE DRAWINGS ACCURATELY REFLECTS THE ORIGINAL DESIGN, ADDENDA, CHANGE ORDERS AND MATERIAL DESIGN CHANGES MADE DURING CONSTRUCTION AND FIELD REVIEWED BY ME, OR MY REPRESENTATIVE, AND THAT THE AS-CONSTRUCTED WORKS SUBSTANTIALLY COMPLY WITH THE ORIGINAL DESIGN INTENT. HOWEVER, I DO NOT ACCEPT RESPONSIBILITY FOR THE ACCURACY OR COMPLETENESS OF THE AS-CONSTRUCTED INFORMATION SUPPLIED BY OTHERS CONTAINED IN THESE DRAWINGS."

CONSULTANT

**BINNIE**  
The people behind your infrastructure.

R.F. BINNIE & ASSOCIATES LTD.  
314-9440 202 Street  
Langley, BC V1M 4A6  
TEL 604 574 3336  
BINNIE.com

CITY OF SURREY

CLIENT

**CITY OF SURREY**  
13450 - 104 AVENUE, SURREY, BC, CANADA V3T 1V8

**SOUTH SURREY ARENA**  
EROSION AND SEDIMENT CONTROL PLAN STAGE 1  
PLAN

SCALE	0 1:250 10m
DATE	(YYYY.MM.DD) 2021-08-13
DESIGNED	JEB
DRAWN	SV
REVIEWED	KN

CONSULTANT PROJ. NO.	21-0714	SURREY PROJECT NUMBER	
DWG. NO.	ESC1	DRAWING TYPE	ESC
REV. 3		SHEET 4 OF 6	



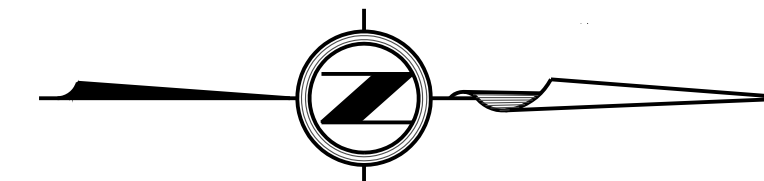
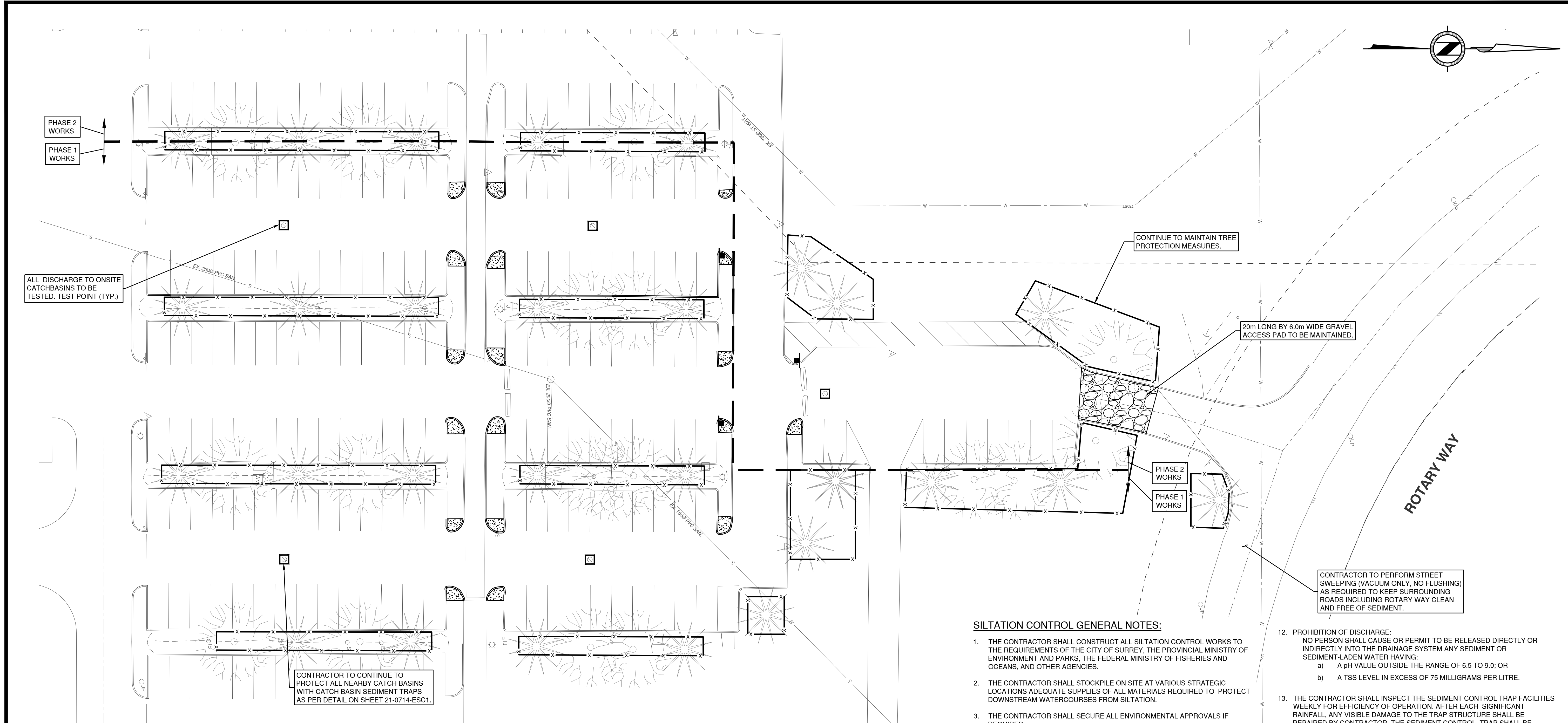

**SILTATION CONTROL GENERAL NOTES:**

- THE CONTRACTOR SHALL CONSTRUCT ALL SILTATION CONTROL WORKS TO THE REQUIREMENTS OF THE CITY OF SURREY, THE PROVINCIAL MINISTRY OF ENVIRONMENT AND PARKS, THE FEDERAL MINISTRY OF FISHERIES AND OCEANS, AND OTHER AGENCIES.
- THE CONTRACTOR SHALL STOCKPILE ON SITE AT VARIOUS STRATEGIC LOCATIONS ADEQUATE SUPPLIES OF ALL MATERIALS REQUIRED TO PROTECT DOWNSTREAM WATERCOURSES FROM SILTATION.
- THE CONTRACTOR SHALL SECURE ALL ENVIRONMENTAL APPROVALS IF REQUIRED.
- THE CONTRACTOR SHALL COVER ANY SOIL STOCKPILES AND EXPOSED EARTH FILL SLOPES WITH 6 MIL POLYETHYLENE.
- THE CONTRACTOR SHALL PLACE SILT FENCING AROUND SOIL STOCKPILES AND AT THE TOE OF EARTH FILL SLOPES.
- THE CONTRACTOR SHALL ENSURE RUNOFF FROM SOIL STOCKPILES AND EXPOSED EARTH FILL SLOPES SHALL BE DIRECTED TO THE SILTATION CONTROL FACILITIES.
- ALL RUNOFF WITHIN BLDG. EXCAVATIONS IS TO BE PUMPED TO ON SITE SILT TRAPS OR INTERCEPTOR SWALE.
- THE CONTRACTOR SHALL REPAIR MACHINE TRACKS OR OTHER SURFACE DEFORMATIONS WHICH TEND TO ALTER DRAINAGE PATHS, AND TO CONCENTRATE DRAINAGE IN SUCH A WAY AS TO INCREASE EROSION.
- THE CONTRACTOR SHALL ASSESS AND REVIEW THE EFFECTIVENESS OF TEMPORARY SEDIMENT CONTROL MEASURES AND SHALL DETERMINE THE NEED FOR ADDITIONAL MEASURES ON A CONTINUING BASIS.
- THE CONTRACTOR SHALL INSPECT AND MAINTAIN SILTATION CONTROL ON A DAILY BASIS.
- THE CONTRACTOR SHALL CORRECT ANY DEFICIENCIES IN EROSION AND SEDIMENTATION CONTROL IMMEDIATELY. IF THE CONTRACTOR FAILS TO CORRECT THESE DEFICIENCIES IN EROSION AND SEDIMENTATION CONTROL, THIS DEFAULT MAY BE CORRECTED BY THE OWNER AT THE CONTRACTOR'S EXPENSE.
- PROHIBITION OF DISCHARGE:  
NO PERSON SHALL CAUSE OR PERMIT TO BE RELEASED DIRECTLY OR INDIRECTLY INTO THE DRAINAGE SYSTEM ANY SEDIMENT OR SEDIMENT-LADEN WATER HAVING:  
a) A pH VALUE OUTSIDE THE RANGE OF 6.5 TO 9.0; OR  
b) A TSS LEVEL IN EXCESS OF 75 MILLIGRAMS PER LITRE.
- THE CONTRACTOR SHALL INSPECT THE SEDIMENT CONTROL TRAP FACILITIES WEEKLY FOR EFFICIENCY OF OPERATION. AFTER EACH SIGNIFICANT RAINFALL, ANY VISIBLE DAMAGE TO THE TRAP STRUCTURE SHALL BE REPAIRED BY CONTRACTOR. THE SEDIMENT CONTROL TRAP SHALL BE CLEANED OUT BEFORE ITS STORAGE DEPTH COMES HALF FULL. WHEN REMOVING SEDIMENT, PLACE SEDIMENT WHERE IT WILL NOT ENTER A STORM DRAIN OR WATER COURSE AND WHERE IT WILL NOT RE ENTER THE SEDIMENT TRAP.
- IT IS IMPORTANT THAT THE ROADWAYS BE KEPT CLEAN AND FREE OF SEDIMENT FROM TRUCKS LEAVING THE SITE. THE CONTRACTOR SHALL PERFORM STREET SWEEPING TO THE EXTENT NEEDED TO ENSURE THAT THIS AND OTHER ADJACENT ROADS ARE KEPT CLEAN.
- THE CONTRACTOR SHALL MAINTAIN ALL ON AND OFF SITE SEDIMENT TRAPS UNTIL PROPOSED CONSTRUCTION IS COMPLETE.
- UPON COMPLETION OF CONSTRUCTION, THE CONTRACTOR SHALL REMOVE ALL SILT FROM THE ON SITE STORM MAINS & DREDGE FLOW CONTROL MANHOLE TO THE SATISFACTION OF ENGINEER.
- THE DEVELOPER TO PROVIDE AN ENVIRONMENTAL ENGINEERING CONSULTANT ON CALL IN CASE CONTAMINATED SOILS ARE DISCOVERED DURING EXCAVATION.

**CURB AND SUBBASE REPLACEMENT STAGE**

- ALL ACCESS TO AND FROM SITE TO BE FROM THE RESTRICTED ENTRY/EXIT POINTS.
- ESC SUPERVISOR TO CONDUCT MONITORING AS PER THE CITY OF SURREY MONITORING AND REPORTING REQUIREMENTS.
- CONTRACTOR TO ENSURE THAT ESC MEASURES ARE WELL MAINTAINED, CLEARED, REPAIRED, OR REPLACED AS REQUIRED.
- CATCH/LAWN BASINS COMPLETE WITH PROTECTIVE MEASURES ARE TO BE INSTALLED BY THE CONTRACTOR AT THE FIRST OPPORTUNITY.
- CONTRACTOR TO CO-ORDINATE THE ELIMINATION OF TEMPORARY ESC FACILITIES IF THEY ARE NO LONGER REQUIRED OR TO FACILITATE SITE OPERATIONS WITH THE ESC SUPERVISOR. ADDITIONAL ESC FACILITIES MAY NEED TO BE INSTALLED AS PER THE DIRECTION OF THE ESC SUPERVISOR.

**ISSUED FOR QUOTATION**

LEGAL DESCRIPTION		SURVEY BENCHMARK MON: 92H0852 N: 5433925.444 E: 513937.358 SCALE FACTOR: 0.9996 ELEV: 108.412	
REV.	DATE	DESCRIPTION	BY
3	2022.03.08	ISSUED FOR QUOTATION	JEB
2	2021.12.22	RE-ASSUED FOR ESC PERMIT	JEB
1	2021.09.20	ISSUED FOR ESC PERMIT	JEB

"BY SEALING AND SIGNING THIS DRAWING, I CERTIFY THAT THE INFORMATION CONTAINED IN THESE DRAWINGS ACCURATELY REFLECTS THE ORIGINAL DESIGN, ADDENDA, CHANGE ORDERS AND MATERIAL DESIGN CHANGES MADE DURING CONSTRUCTION AND FIELD REVIEWED BY ME, OR MY REPRESENTATIVE, AND THAT THE AS-CONSTRUCTED WORKS SUBSTANTIALLY COMPLY WITH THE ORIGINAL DESIGN INTENT. HOWEVER, I DO NOT ACCEPT RESPONSIBILITY FOR THE ACCURACY OR COMPLETENESS OF THE AS-CONSTRUCTED INFORMATION SUPPLIED BY OTHERS CONTAINED IN THESE DRAWINGS."

CONSULTANT

**BINNIE**  
The people behind your infrastructure.

R.F. BINNIE & ASSOCIATES LTD.  
314-9440 202 Street  
Langley, BC V1M 4A6  
TEL 604 574 3336  
BINNIE.com

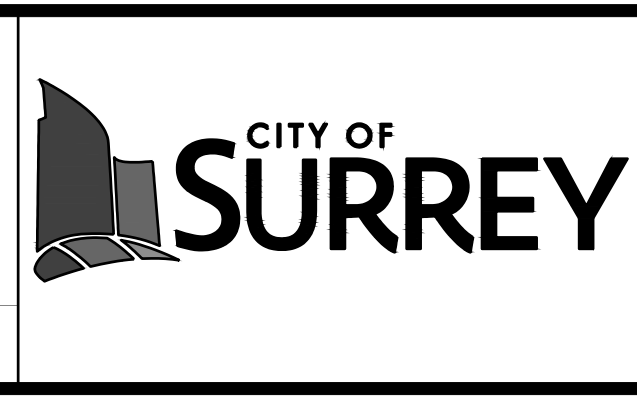

CLIENT

**CITY OF SURREY**  
13450 - 104 AVENUE, SURREY, BC, CANADA V3T 1V8

**SOUTH SURREY ARENA**  
EROSION AND SEDIMENT CONTROL PLAN STAGE 2  
PLAN

SCALE	DATE (YYYY.MM.DD)	SURREY PROJECT NUMBER
0 1:250 10m	2021-08-13	
DESIGNED	CONSULTANT PROJ. NO.	DRAWING TYPE
JEB	21-0714	ESC
DRAWN	DWG. NO.	REV.
SV	ESC2	3
REVIEWED		
KN		

DATE (YYYY.MM.DD)	CONSULTANT PROJ. NO.	DRAWING TYPE
2021-08-13	21-0714	ESC
DWG. NO.	REV.	SHEET 5 OF 6
ESC2	3	



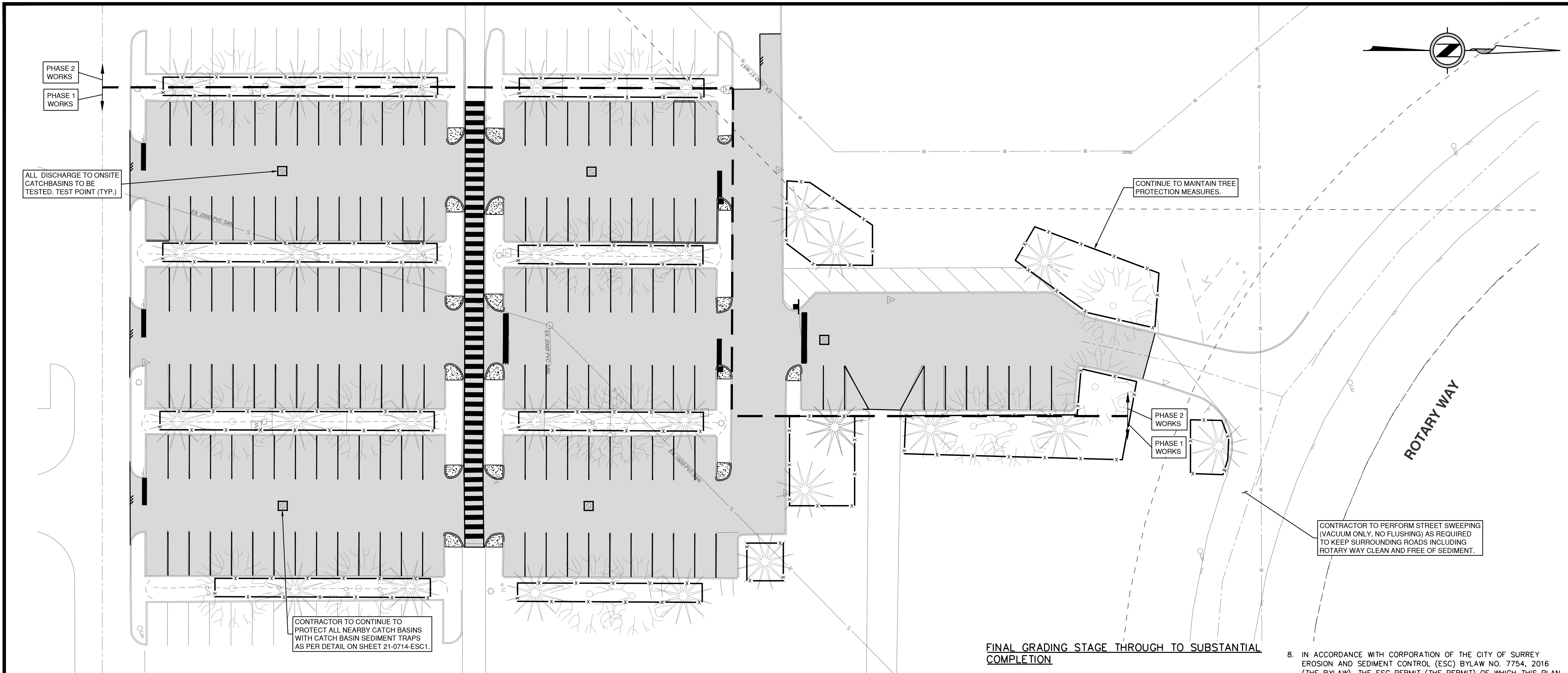

**MAINTENANCE ALL STAGES (AS APPLICABLE)**

1. ALL INSPECTIONS/MONITORING TO BE CARRIED OUT BY ENGINEER OF RECORD OR ESC SUPERVISOR UP TO THE EXPIRY OF THE PERMIT.
2. UPON INSTRUCTION/NOTIFICATION BY THE ENGINEER OF RECORD OR ESC SUPERVISOR, PERSONS RESPONSIBLE ARE REQUIRED TO UNDERTAKE MAINTENANCE ACTIVITIES AS DEEMED SPECIFIED TO MODIFY OR MAINTAIN ESC FACILITIES.
3. ALL CATCH BASIN FILTER SOCKS ARE TO BE INSPECTED WEEKLY OR FOLLOWING STORM EVENTS, INLINE FILTERS ARE TO BE REMOVED AND CLEANED AT 40% CAPACITY.
4. ACCUMULATED SEDIMENT DEPOSITION IN THE SILT SUMP TO BE REMOVED AT 50% CAPACITY.
5. GRAVEL ACCESS PADS TO BE INSPECTED DAILY TO ENSURE FUNCTIONALITY, ADD ADDITIONAL ROCK AS REQUIRED.
6. THE DEVELOPER OR BUILDER MUST REGULARLY CLEAN PAVED ROAD SURFACES OF ACCUMULATED SEDIMENTS AT THE END OF EACH DAY OR AS REQUIRED. NO SOIL, SAND OR OTHER MATERIAL WITH A HIGH SEDIMENT CONTENT SHALL BE DEPOSITED OR PILED OUTSIDE OF THE PROPERTY BOUNDARIES, PARTICULARLY ON PAVED ROAD SURFACES.
7. SEDIMENT FENCES/BARRIERS TO BE INSPECTED AND REPAIRED PRIOR TO EXPECTED RAIN EVENTS AND FOLLOWING ALL SIGNIFICANT STORM EVENTS OR PERIODS OF EXTENDED RAIN; ACCUMULATED SEDIMENTS GREATER THAN 30% OF THE FENCE CAPACITY OR DEFICIENCIES SHOULD BE DEALT WITH ACCORDINGLY.
8. ALL SEDIMENT REMOVED FROM ESC CONTROL FACILITIES TO BE DISPOSED OF IN A MANNER AS TO NOT COMPOUND OR COMPROMISE THE SEDIMENT LOADING OF OTHER CONTROL MEASURES.

LOCATION OF CITY RAIN GAUGE = WHITE ROCK  
 I THE ESC SUPERVISOR, HEREBY CERTIFY THAT I HAVE REVIEWED THIS ESC PLAN  
 ESC SUPERVISOR JON BRIDLE, P. ENG.

**DECOMMISSION NOTES:**

- DECOMMISSION AND BACKFILL OF SEDIMENT CONTROL FACILITIES SHALL CONSIST OF THE FOLLOWING WORKS:
1. REMOVAL OF TREATMENT SYSTEM ONLY WITH CITY OF SURREY ENVIRONMENT STAFF APPROVAL.
  2. REMOVE ACCUMULATED SILTS, POLYLINER AND SILT FENCING FROM SWALE.
  3. UPON COMPLETION OF CONSTRUCTION, CONTRACTOR SHALL REMOVE ALL SILT FROM ON-SITE STORM MAINS AND SHALL DREDGE THE STORM WATER SEDIMENT TRAPS TO THE SATISFACTION OF THE ENGINEER

**FINAL GRADING STAGE THROUGH TO SUBSTANTIAL COMPLETION**

1. GENERAL CONTRACTOR TO ENSURE THAT STORMWATER CONVEYANCE CHANNELS AND DISCHARGE POINTS TO ADJACENT STREAMS, DITCHES, OR ENTRY POINTS TO PIPED NETWORKS, ARE ADEQUATELY PROTECTED.
2. CONTRACTOR TO ENSURE THAT ESC FACILITIES SPECIFIED IN THE ESC PLAN OR ANY ADDENDUMS ARE IMPLEMENTED ACCORDINGLY.
3. AFTER FINAL LOT GRADING IS COMPLETED ALL DISTURBED AREAS ARE TO BE PROTECTED AS PER THE ESC PLAN.
4. CONTRACTOR TO CO-ORDINATE WITH THE ESC SUPERVISOR THE ELIMINATION OF TEMPORARY ESC FACILITIES AS THEY ARE NO LONGER REQUIRED. ADDITIONAL ESC FACILITIES MAY NEED TO BE INSTALLED AS PER THE DIRECTION OF THE ESC SUPERVISOR.
5. DEVELOPER TO ENSURE THAT THE LOT OWNER AND/OR BUILDER ARE NOTIFIED OF EXISTING ESC FACILITIES AND THEIR RESPONSIBILITIES TO ENSURE THAT INDIVIDUAL PRIVATE ONSITE SEDIMENT CONTROL MEASURES ARE PUT IN PLACE AND PERFORM TO THE STANDARD OF THE ESC BYLAW.
6. DEVELOPER TO RETAIN THE SERVICES OF THE ESC SUPERVISOR UNTIL 90% OF BUILDING CONSTRUCTION INCLUDING LANDSCAPING OF THE LOTS HAS BEEN COMPLETED. THE ESC PERMIT WILL BE IN FULL FORCE AND EFFECT DURING THIS TIME PERIOD.
7. UNDER THIS PLAN, ALL PERSONS INCLUDING BUT NOT LIMITED TO THE DEVELOPER, OWNER OF THE LAND, THE ENGINEER OF RECORD, ESC SUPERVISOR, CIVIL CONTRACTOR, CIVIL SUB-CONTRACTOR, BUILDING & BUILDING SUB-TRADES HEREIN AFTER REFERRED TO AS THE OWNER/DEVELOPER/PERSONS RESPONSIBLE; ENGAGED ON SITE SHALL COMPLY WITH ALL REGULATORY REQUIREMENTS SPECIFIED BY FEDERAL, PROVINCIAL, AND MUNICIPAL AUTHORITIES; PERTAINING TO ON SITE MANAGEMENT AND DISCHARGE ASSOCIATED WITH EROSION AND SEDIMENT CONTROL REGULATIONS.

8. IN ACCORDANCE WITH CORPORATION OF THE CITY OF SURREY EROSION AND SEDIMENT CONTROL (ESC) BYLAW NO. 7754, 2016 (THE BYLAW), THE ESC PERMIT (THE PERMIT) OF WHICH THIS PLAN FORMS PART THEREOF; DEEMS THE PERMIT HOLDER ULTIMATELY RESPONSIBLE FOR ALL SITE ACTIVITIES THAT RESULT IN A BREACH OF COMPLIANCE WITH THE BYLAW, FOR THE DURATION OF THE PERMIT.
9. THE DEVELOPER/PERSONS RESPONSIBLE SHALL ENSURE THAT ALL CONSTRUCTION ACTIVITIES ARE UNDERTAKEN IN A MANNER THAT ENSURE THE BEST MANAGEMENT PRACTICES ARE IMPLEMENTED TO PREVENT AND CONTAIN ON-SITE, SILT LADEN RUNOFF THAT EXCEEDS 75MG/L TSS AS SPECIFIED BY THE BYLAW, FROM ENTERING DOWNSTREAM DRAINAGE INFRASTRUCTURE AND AQUATIC SYSTEMS.
10. THE ESC SUPERVISOR SPECIFIED UNDER THE ESC PERMIT IS RESPONSIBLE TO MONITOR, INSPECT AND REPORT TO THE DEVELOPER, CONTRACTOR, AND CITY ON EROSION AND SEDIMENT CONTROL FACILITIES AND SITE DISCHARGE PERFORMANCE IN ACCORDANCE TO THE CITY'S SEDIMENT CONTROL POLICIES.
11. THE DEVELOPER/OWNER/PERSONS RESPONSIBLE MUST COMPLY WITH THE ESC PLAN WITHIN THE SPECIFIED TIMEFRAME, AND COMPLY WITH ALL INSTRUCTIONS ISSUED BY THE ESC SUPERVISOR TO RECTIFY DEFICIENCIES THAT RESULT IN NON-CONFORMANCE WITH THE PERMIT.
12. ALL SITE AND/OR LOT ACCESS FROM DISTURBED AREAS TO PAVED SURFACES IS TO BE RESTRICTED TO SPECIFIED ACCESS FACILITIES TO LIMIT THE TRANSPORT OF SEDIMENT ONTO ROADWAYS. DURING THE HOMEBUILDING PHASE, VEHICLE ACCESS TO DISTURBED AREAS IS TO BE LIMITED TO GRAVEL PADS ONLY.

**ISSUED FOR QUOTATION**

LEGAL DESCRIPTION		SURVEY BENCHMARK MON: 92H0852 N: 5433925.444 E: 513937.358 SCALE FACTOR: 0.9996 ELEV: 108.412	
REV.	DATE	DESCRIPTION	BY
3	2022-03-08	ISSUED FOR QUOTATION	JEB
2	2021-12-22	RE-ASSUED FOR ESC PERMIT	JEB
1	2021-09-20	ISSUED FOR ESC PERMIT	JEB

"BY SEALING AND SIGNING THIS DRAWING, I CERTIFY THAT THE INFORMATION CONTAINED IN THESE DRAWINGS ACCURATELY REFLECTS THE ORIGINAL DESIGN, ADDENDA, CHANGE ORDERS AND MATERIAL DESIGN CHANGES MADE DURING CONSTRUCTION AND FIELD REVIEWED BY ME, OR MY REPRESENTATIVE, AND THAT THE AS-CONSTRUCTED WORKS SUBSTANTIALLY COMPLY WITH THE ORIGINAL DESIGN INTENT. HOWEVER, I DO NOT ACCEPT RESPONSIBILITY FOR THE ACCURACY OR COMPLETENESS OF THE AS-CONSTRUCTED INFORMATION SUPPLIED BY OTHERS CONTAINED IN THESE DRAWINGS."

CONSULTANT

**BINNIE**  
The people behind your infrastructure.

R.F. BINNIE & ASSOCIATES LTD.  
314-9440 202 Street  
Langley, BC V1M 4A6  
TEL 604 574 3336  
BINNIE.com

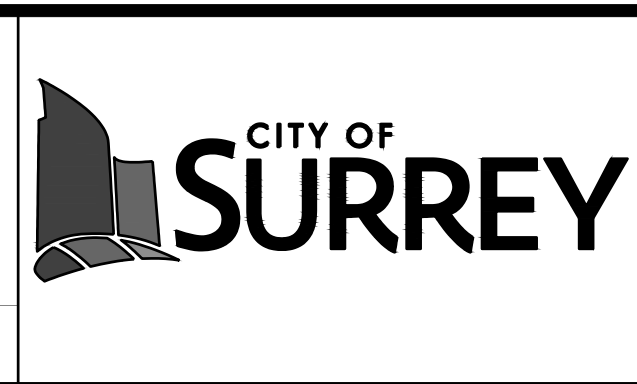

CLIENT

**CITY OF SURREY**  
13450 - 104 AVENUE, SURREY, BC, CANADA V3T 1V8

**SOUTH SURREY ARENA**  
EROSION AND SEDIMENT CONTROL PLAN STAGE 3  
PLAN

SCALE	0 1:250 10m
DESIGNED	JEB
DRAWN	SV
REVIEWED	KN

DATE (YYYY.MM.DD)	2021-08-13	SURREY PROJECT NUMBER	
CONSULTANT PROJ. NO.	21-0714	DRAWING TYPE	ESC
DWG. NO.	ESC3	REV.	3
		SHEET	6 OF 6



**SCHEDULE B  
APPENDICES 3 THROUGH 7**

Information from Schedule C of the RFQ will be inserted at the time of the award of the Contract:

- Appendix 3 Schedule of Quantities and Prices
- Appendix 4 Construction Schedule
- Appendix 5 Key Personnel, Sub-Contractors, and Material Suppliers

The following forms to be included at the time of the award of the contract:

- Appendix 6 Prime Contractor Designation
- Appendix 7 Contractor Health & Safety Expectations (Responsibility of Contractor(s))



## SCHEDULE C – FORM OF QUOTATION

**RFQ Title: South Surrey Indoor Arena Parking Lot Rehabilitation**

**RFQ No: 1220-040-2022-025**

### CONTRACTOR

**Legal Name of Contractor:** \_\_\_\_\_

**Contact Person and Title:** \_\_\_\_\_

**Business Address:** \_\_\_\_\_

**Business Telephone:** \_\_\_\_\_

**Business Fax:** \_\_\_\_\_

**Business E-Mail Address:** \_\_\_\_\_

TO:

### CITY OF SURREY

City Representative: Sunny Kaila, Manager, Procurement Services

Email for PDF Files: [purchasing@surrey.ca](mailto:purchasing@surrey.ca)

1. If this Quotation is accepted by the City, a contract will be created as described in:
  - (a) the Contract;
  - (b) the RFQ; and
  - (c) other terms, if any, that are agreed to by the parties in writing.
2. Capitalized terms used and not defined in this Quotation will have the meanings given to them in the Contract and RFQ. Except as specifically modified by this Quotation, all terms, conditions, representations, warranties and covenants as set out in the Contract and RFQ will remain in full force and effect.
3. I/We have reviewed the sample Contract (Schedule B). If requested by the City, I/we would be prepared to enter into the sample Contract, amended by the following departures (list, if any):

**Section**

**Requested Departure(s) / Alternative(s)**

\_\_\_\_\_

---

4. The City requires that the successful Contractor have the following in place **before providing the Work**:

- (a) Workers' Compensation Board coverage in good standing and further, if an "Owner Operator" is involved, personal operator protection (P.O.P.) will be provided,  
Workers' Compensation Registration Number \_\_\_\_\_;
- (b) Prime Contractor qualified coordinator is Name: \_\_\_\_\_  
and Contact Number: \_\_\_\_\_;
- (c) Insurance coverage for the amounts required in the proposed Contract as a minimum, naming the City as additional insured and generally in compliance with the City's sample insurance certificate form available on the City's Website at [www.surrey.ca](http://www.surrey.ca). search [Standard Certificate of Insurance](#);
- (d) City of Surrey or Intermunicipal Business License: Number \_\_\_\_\_;
- (e) If the Contractor's goods and services are subject to GST, the Contractor's GST Number is \_\_\_\_\_; and
- (f) If the Contractor is a company, the company name indicated above is registered with the Registrar of Companies in the Province of British Columbia, Canada, Incorporation Number \_\_\_\_\_.

As of the date of this Quotation, we advise that we have the ability to meet all of the above requirements **except as follows** (list, if any):

<b>Section</b>	<b>Requested Departure(s) / Alternative(s)</b>
----------------	--

---

---

5. The Contractor acknowledges that the departures it has requested in Sections 3 and 4 of this Quotation will not form part of the Contract unless and until the City agrees to them in writing by initialing or otherwise specifically consenting in writing to be bound by any of them.

**Changes and Additions to Specifications and Scope:**

6. In addition to the warranties provided in the Contract, this Quotation includes the

---

---

---

7. I/We have reviewed the RFQ, Schedule A – Scope of Work and Contract Drawings. If requested by the City, I/we would be prepared to meet those requirements, amended by the following departures and additions (list, if any):

**Requested Departure(s) / Alternative(s) / Addition(s)**

---



---



---



---

**SCHEDULE OF QUANTITIES AND PRICES**

8. The Contractor offers to supply to the City of Surrey the Goods and Services for the prices plus applicable taxes as follows:

**Table 1 – Summary Sheet:**

F.O.B. Destination	Payment Terms: A cash discount of ____% will be allowed if invoices are paid within ____ days, or the ____ day of the month following, or net 30 days, on a best effort basis.	Ship Via:
<b>Section</b>	<b>Title</b>	<b>Amount</b>
DIV 01	GENERAL REQUIREMENTS	\$
DIV 03	CONCRETE	\$
DIV 31	EARTHWORK	\$
DIV 32	ROADS AND SITE IMPROVEMENTS	\$
	Subtotal – Quotation Price:	\$
	GST:	\$
	<b>Quotation Price, including GST:</b>	<b>\$</b>

**Table 2 – Schedule of Quantities and Prices:***(Carry these amounts forward to Table 1 - Summary Sheet)*

<b>Item No.</b>	<b>MMCD Section</b>	<b>Specification Title</b>	<b>Unit</b>	<b>Quantity</b>	<b>Unit Price</b>	<b>Amount</b>
<b>DIV 01</b>		<b>GENERAL REQUIREMENTS</b>				
	<b>01 55 00</b>	<b>Traffic Control, Vehicle Access and Parking</b>				
1.01	SSP	Traffic Control, Vehicle Access and Parking – South Surrey Arena Parking Lot	LS	1	\$	\$
	<b>01 57 01</b>	<b>Environmental Protection</b>				
1.02	SSP	Erosion and Sediment Control – South Surrey Arena Parking Lot	LS	1	\$	\$
<b>DIV 03</b>		<b>CONCRETE</b>				
	<b>03 30 20</b>	<b>Concrete Walks, Curbs and Gutters</b>				
3.01	1.4.4	Concrete Extruded Curb (per detail on contract drawings)	Lin. m	160	\$	\$
3.02	1.4.5	Concrete Infill (100mm thick, incl. 19mm granular base)	Sq. m	60	\$	\$
<b>DIV 31</b>		<b>EARTHWORK</b>				
	<b>31 11 41</b>	<b>Shrub and Tree Preservation</b>				
31.01	1.3.1	Tree Protection	LS	1	\$	\$
	<b>31 24 13</b>	<b>Roadway Excavation, Embankment and Compaction</b>				
31.02	SSP	Mass Excavation and Removal – South Surrey Arena Parking Lot	LS	1	\$	\$
31.03	SSP	Common Excavation - Off-Site Disposal	cu. m	35	\$	\$
<b>DIV 32</b>		<b>ROADS AND SITE IMPROVEMENTS</b>				
	<b>32 01 16.7</b>	<b>Cold Milling</b>				
32.01	1.5.1	Surface Milling 40mm Thick	Sq. m	2,250	\$	\$
32.02	1.5.1	Full Depth Milling 40mm Thick	Sq. m	3,230	\$	\$
	<b>32 11 23</b>	<b>Granular Base</b>				
32.03	1.4.2	19mm Minus Crushed Granular Base	tonne	220	\$	\$
	<b>32 12 13.1</b>	<b>Asphalt Tack Coat</b>				
32.04	1.5.1	Asphalt Tack Coat - Emulsified Asphalt	Sq. m	5,550	\$	\$
	<b>32 12 16</b>	<b>Hot-Mix Asphalt Concrete Paving</b>				
32.05	1.5.1	Asphalt Concrete Pavement Lower Course #2, 45mm Thick	tonne	360	\$	\$

<b>Item No.</b>	<b>MMCD Section</b>	<b>Specification Title</b>	<b>Unit</b>	<b>Quantity</b>	<b>Unit Price</b>	<b>Amount</b>
32.06	1.5.1	Asphalt Concrete Pavement Upper Course #2, 40mm Thick	tonne	520	\$	\$
32.07	1.5.1	CB/MH Adjustments	Incidental			
32.08	1.5.3	Asphalt Commercial Driveway Upper Course #2, 85mm Thick	Sq. m	30	\$	\$
32.09	1.5.3	Speed Hump	Each	2	\$	\$
	<b>32 17 23</b>	<b>Painted Pavement Markings</b>				
32.10	1.5.3	Permanent Pavement Markings - Paint	LS	1	\$	\$
32.11	1.5.4	Supply and Install Signs and Posts	Each	3	\$	\$
	<b>32 91 21</b>	<b>Topsoil and Finish Grading</b>				
32.12	1.4.1	Imported Topsoil 150mm Thick	Sq. m	50	\$	\$
	<b>32 92 20</b>	<b>Seeding</b>				
32.13	1.8.1	Hand Seeding	Sq. m	50	\$	\$
<b>OPT</b>		<b>OPTIONAL WORKS</b>				
OPT 1	SSP	Price adjustment to complete all works without phasing.	LS	1	\$	\$
OPT 2	SSP	Price Adjustment to install all thermoplastic pavement markings instead of paint	LS	1	\$	\$

**List of Optional Prices:**

9. The following is a list of Optional Price(s) to the Work and forms part of this RFQ, upon the acceptance of any or all of the Optional Price(s). The Optional Prices are an addition or a deduction to the Total Quotation Price and do not include GST. DO NOT state a revised Total Quotation Price.

Description of Optional Prices	Addition	Deduction
OP-1. Price Adjustment to complete all works without phasing	\$ [            ]	\$ [            ]
OP-2. Price Adjustment to install all Thermoplastic pavement markings Instead of paint	\$ [            ]	\$ [            ]

**List of Separate Prices:**

10. The following is a list of Separate Price(s) to the Work and forms part of this RFQ, upon the acceptance of any or all of the Separate Price(s). The Separate Prices are an addition or a deduction to the Total Quotation Price and do not include GST. DO NOT state a revised Total Quotation Price.

Description of Separate Price Items	Addition	Deduction
SP-1. Performance Bond at 50% of total contract value:		
CCDC 221 (latest Preferred)	\$[            ]	\$[            ]
SP-2. Labour and Material Payment Bond at 50% of total contract value:		
CCDC 222 (latest Preferred)	\$[            ]	\$[            ]

**Force Account Labour and Equipment Rates:**

11. Contractors should complete the following tables setting out the all-inclusive hourly labour rates including Overhead and profit for approved extras/credits for all applicable categories of labour (use the spaces provided and/or attach additional pages, if necessary):

**Table 1 – Hourly Labour Rate Schedule for Services:**

Labour Category	Straight Time/hr (Plus GST)	Overtime Rate/hr (Plus GST)
.1 Superintendent	\$	\$
.2 Foreman	\$	\$
.3 Journeyman	\$	\$
.4 Apprentice	\$	\$
.5 Skilled Labourer	\$	\$
.5	\$	\$
.6	\$	\$

**Table 2 – Hourly Equipment Rate Schedule:**

No.	Equipment Description ( <i>State</i> )	Hourly Equipment Rate
		\$
		\$

**Preliminary Construction Schedule:**

12. Contractors should provide a preliminary construction schedule, with major item descriptions and time:

- (a) Commence the Work on or before: \_\_\_\_\_; and
- (b) to achieve Substantial Performance of the Work on or before: \_\_\_\_\_ (WORK DURATION).

Contractor should provide a Microsoft Project (or similar) schedule outlining the Critical Path and should include all major phases of the Work and indicate start and substantial completion dates for each.

ACTIVITY	Time from Notice to Proceed in Days									
	10	20	30	40	50	60	70	80	90	100
	<b>SAMPLE</b>									

Proposed Disposal Site: \_\_\_\_\_

**Key Personnel & Subcontractors:**

13. Contractors should provide information on the background and experience of all key personnel proposed for the performance of the Work (use the spaces provided and/or attach additional pages, if necessary):

Name: \_\_\_\_\_

Experience: \_\_\_\_\_

Dates: \_\_\_\_\_

Project Name: \_\_\_\_\_

Responsibility: \_\_\_\_\_

Responsibility: \_\_\_\_\_

14. Contractors should identify subcontractors, if any, the Contractor intends to use for the performance of the Work, describe the portion of the Work proposed to be subcontracted and a description of the relevant experience of the subcontractor, using a format similar to the following:

<i>Subcontractor Services</i>	<i>Subcontractor Name</i>	<i>Years of Working with Contractor</i>	<i>Business Telephone Number and Business Email Address</i>



The City reserves the right of approval for each of the subcontractors and material suppliers. The Contractor will be given the opportunity to substitute an acceptable subcontractor and material supplier, if necessary.

**Experience, Reputation and Resources**

- 15. Contractors should provide information on their relevant experience and qualifications for the performance of the Work similar to those required by the Contract (use the spaces provided and/or attach additional pages, if necessary):

---

---

- 16. Contractors should provide references for work performed by your firm of a similar nature and value (name and telephone number). The City's preference is to have a minimum of three references. Previous clients of the Contractor may be contacted at the City's discretion (use the spaces provided and/or attach additional pages, if necessary)

---

---

- 17. I/We the undersigned duly authorized representatives of the Contractor, having received and carefully reviewed the RFQ and the Contract, submit this Quotation in response to the RFQ.

This Quotation is executed by the Contractor this \_\_\_\_\_ day of \_\_\_\_\_, 202\_\_.

**CONTRACTOR**

I/We have the authority to bind the Contractor.

\_\_\_\_\_  
(Legal Name of Contractor)

\_\_\_\_\_  
(Signature of Authorized Signatory)

\_\_\_\_\_  
(Signature of Authorized Signatory)

\_\_\_\_\_  
(Print Name and Position of Authorized Signatory)

\_\_\_\_\_  
(Print Name and Position of Authorized Signatory)

**ATTACHMENT 1 - CITY OF SURREY, PROJECT COMPLETION DELIVERABLES WORKSHEET**

Project Name: \_\_\_\_\_

Project Address: \_\_\_\_\_

Date: \_\_\_\_\_

End of Project Walk-through: \_\_\_\_\_

End of Project Walk-through: \_\_\_\_\_

City Representative: \_\_\_\_\_

Contractor/Contractor Rep: \_\_\_\_\_

Department: \_\_\_\_\_

Company Name: \_\_\_\_\_

Contact phone number: \_\_\_\_\_

Contact phone number: \_\_\_\_\_

Fax number: \_\_\_\_\_

Fax number: \_\_\_\_\_

**A. BUILDING PERMITS – CLOSED OUT**

- Architectural
- Electrical
- Mechanical / Plumbing
- Structural
- Other

**B. O&M MANUALS RECEIVED**

*\*Shop Drawings to be included in O&M Manuals*

Architectural

- 1 Electronic (PDF) file
- 2 Hardcopies

Electrical

- 1 Electronic (PDF) file
- 2 Hardcopies

Mechanical

- 1 Electronic (PDF) file
- 2 Hardcopies

Other(s)

- 1 Electronic (PDF) file
- 2 Hardcopies

**C. PROJECT CLOSE-OUT**

- Project Summary Report
- Substantial Completions
- Deficiencies List
- Transfer of Utilities (Hydro/Teresan)  
Notify City of Surrey (604-591-4804)
- Asset Inventory Forms including HVAC
- TCA Cost Summary Finance, & Warranty  
Information sheets & Project summary  
with graphics
- Final Occupancy Certification
- All documentation/correspondence  
pertaining to the project (File Share Device)

**E. AS-BUILT DRAWING SUBMITTALS**

Architectural

- 1 Set of AutoCAD As-Built DWG files
- 1 Set of PDF As-Built drawings
- 1 Set of paper construction drawings

Civil

- 1 Set of AutoCAD As-Built DWG files
- 1 Set of PDF As-Built drawings
- 1 Set of paper construction drawings

Electrical

- 1 Set of AutoCAD As-Built DWG files
- 1 Set of PDF As-Built drawings
- 1 Set of paper construction drawings

Fire Protection

- 1 Set of AutoCAD As-Built DWG files
- 1 Set of PDF As-Built drawings
- 1 Set of paper construction drawings

Landscaping

- 1 Set of AutoCAD As-Built DWG files
- 1 Set of PDF As-Built drawings
- 1 Set of paper construction drawings

Mechanical / Plumbing

- 1 Set of AutoCAD As-Built DWG files
- 1 Set of PDF As-Built drawings
- 1 Set of paper construction drawings

Structural

- 1 Set of AutoCAD As-Built DWG files
- 1 Set of PDF As-Built drawings
- 1 Set of paper construction drawings

Other:

- 1 Set of AutoCAD As-Built DWG files
- 1 Set of PDF As-Built drawings
- 1 Set of paper construction drawings

**D. FALL PROTECTION / RESTRAINT SYSTEM**

- Complete
- Wall plaques displayed as required
- 1 (PDF) containing the Fall Protection Safety

**F. FIRE SAFETY PLAN**

- Complete
- Wall plaques displayed throughout facility
- 1 Electronic (PDF) file of the fire safety plan
- 2 paper copies of the fire safety plan

System \_\_\_\_\_

Signed:

\_\_\_\_\_  
City Representative

\_\_\_\_\_  
Contractor Representative

\_\_\_\_\_  
Internal Representative

\_\_\_\_\_  
Fire Chief/ Representative

## ATTACHMENT 2

### PRIME CONTRACTOR DESIGNATION LETTER OF UNDERSTANDING

As per the requirements of the *Workers' Compensation Act* Part 3, Division 3, Section 118 (1-3), which states:

#### Coordination of multiple-employer workplaces

**118 (1) In this section:**

"multiple-employer workplace" means a workplace where workers of 2 or more employers are working at the same time:

"prime contractor" means, in relation to a multiple-employer workplace,

- (a) the directing contractor, employer or other person who enters into a written agreement with the owner of that workplace to be the prime contractor for the purposes of this Part, or
  - (b) if there is no agreement referred to in paragraph (a), the owner of the workplace.
- (2) The prime contractor of a multiple-employer workplace must
- (a) ensure that the activities of employers, workers and other persons at the workplace relating to occupational health and safety are coordinated, and
  - (b) do everything that is reasonably practicable to establish and maintain a system or process that will ensure compliance with this Part and the regulation in respect to the workplace.
- (3) Each employer of workers at a multiple-employer workplace must give to the prime contractor the name of the person the employer has designated to supervise the employer's workers at that workplace.

By signing this Contract, the Contractor accepts all responsibilities of a prime contractor as outlined in the *Workers' Compensation Act*, and *WorksafeBC OH&S Regulation*.

As a Contractor signing this Prime Contractor Designation form with the City of Surrey (the "owner"), you are agreeing that your company, management staff, supervisory staff and workers will comply with the *Workers' Compensation Board (WCB) Occupational Health and Safety Regulation* and the *Workers' Compensation (WC) Act*.

Any *WorksafeBC OH&S* violation by the prime contractor may be considered a breach of contract resulting in possible termination or suspension of the Contract and/or any other actions deemed appropriate at the discretion of the City.

Any penalties, sanctions or additional costs levied against the City, as a result of the actions of the prime contractor are the responsibility of the prime contractor.

The Contractor acknowledges having read and understood the information above.

By signing this Prime Contractor Designation form, the Contractor agrees as a representative of the firm noted below, to accept all responsibilities of the prime contractor for this project.

**The Contractor understands and accepts the responsibilities of the prime contractor designation in accordance with the *Workers' Compensation Act* while contracted by the City of Surrey for project and will abide by all *Workers' Compensation Board Regulation* requirements.**

Project File No.: 1220-040-2022-025

Project Title and Site Location: South Surrey Indoor Arena Parking Lot Rehabilitation

Prime Contractor Name: \_\_\_\_\_

Prime Contractor Address: \_\_\_\_\_

Telephone/Fax Numbers: Phone: \_\_\_\_\_ Fax: \_\_\_\_\_

Name of Person in Charge of Project: \_\_\_\_\_

Name of Person Responsible for Coordinating Health & Safety Activities: \_\_\_\_\_

Phone: \_\_\_\_\_

Prime Contractor Signature: \_\_\_\_\_ Date: \_\_\_\_\_

Please return a signed copy of this memo to the City of Surrey, Finance Department, Procurement Services, 13450 – 104 Avenue, Surrey, British Columbia, V3T 1V8

If you have any questions, please contact the City of Surrey, Manager Occupational Health & Safety at 604-591-4658.

## **ATTACHMENT 3**

### **CONTRACTOR HEALTH & SAFETY EXPECTATIONS**

#### **RESPONSIBILITY OF CONTRACTOR(S)**

The City of Surrey strives to maintain a safe work environment for employees and contractors and insists upon the enforcement of safe practices and procedures in all premises and in all work activities. It is essential that all contractors and their employees and sub-contractor(s) perform in the same manner. It is every employers and contractors responsibility to ensure that staff and public are protected from workplace hazards.

As a contractor to the City of Surrey, you are expected to conform to the requirements of the Workers' Compensation Act, the WCB Occupational Health and Safety Regulation and to all federal, provincial and local laws and regulations. The City of Surrey Building Owner, Project Manager, and the Manager, Occupational Health & Safety or designate have the authority to order an unsafe act to cease or to have an unsafe piece of equipment removed from the premises or, in extreme situations, to shut down a job entirely. Any City of Surrey Employee that observes a safety infraction by a contractor performing work for the City of Surrey should bring it to the attention of a manager immediately or Occupational Health & Safety (604-591-4131).

The following information is provided as typical City of Surrey requirements, but does not relieve the contractor from complying with all applicable local, provincial and federal laws, regulations and bylaws.

#### **PERSONNEL**

1. You are expected to inform your employees of any potential hazard in the workplace and advise of appropriate action to be taken should a hazard be found or a fire or accident occur.
2. Contractors will restrict persons invited on the premises to employees only. No families or friends are permitted.
3. The contractor will advise the City of any on-site accidents involving the contractor's employees, or injuries to others caused by the contractor's business.

#### **SAFETY MANAGEMENT SYSTEM**

1. Contractors will ensure their employees utilize proper safety equipment and clothing as required for job site activities.
2. Contractors must follow and have on site proper written safe work procedures for hazardous work, e.g., Fall protection, confined space entry, hotwork, lockout, excavations and shoring, traffic management, etc.
3. Contractor must Identify workplace risk and implement suitable controls.
4. Contractor must provide safety training and education to staff and have training records available for review.
5. Contractor must have a health & safety program for its workers and sub-contractors
6. Contractor will provide appropriate First-Aid coverage for their workers and subcontractors.
7. Contractor must forward a weekly work task list prior to work commencement.
8. The qualified safety coordinator must participate in the City of Surrey OHS Orientation or attend the Prime Contractor's Orientation.

## **WORK AREAS –City Facilities**

No work by contractors shall occur in any area without prior consent of the City of Surrey Manager, Civic Facilities or his designated representative. Work during normal business hours of the City shall not create undue noise, smells or otherwise unduly disturb the work of City of Surrey staff or the public. If an activity requires that a disturbance is likely, the contractor shall whenever possible only do that work outside normal business hours.

All activities that create a hazard (i.e., work from a ladder, removal of a floor tile, emission of VOC's, etc.) to persons outside the contractor's supervision shall have warning devices, delineation or barriers, sealed spaces, etc. as would normally be required to protect any person from that hazard.

## **SAFETY ATTITUDE**

Your safety record and attitude are important criteria used to judge your qualification for future bidding on solicitations with the City of Surrey.

You can help ensure employee safety and your eligibility for future business with the City if you exhibit and practice a "Safe Work - Safe City" attitude.

The City of Surrey is concerned about the health, safety and wellbeing of all employees and contractors. It is essential we maintain a healthy, safe and productive work environment.

### **All Employees & Contractors:**

It is everyone responsibility to:

- ❖ know and comply with WCB regulations and
- ❖ follow established safe work procedures
- ❖ immediately report any work related injury to his/her supervisor; and to the city representative
- ❖ not remain on the work site while his/her ability to work is in any way impaired
- ❖ report unsafe acts and conditions to their supervisor
- ❖ correct unsafe conditions immediately whenever it is possible to do so
- ❖ take reasonable care to protect your health & safety and the health and safety of other persons who may be affected by your act's or omissions at work

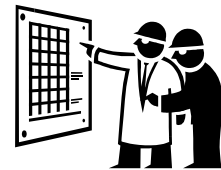

An employee must refuse to work if continuing to do so would endanger the health and safety of the employee, fellow employees or others. The worker must immediately report the circumstances of the unsafe condition to his or her supervisor or manager. If the unsafe condition is not remedied or the issue is not resolved the Manager, Occupational Health & Safety must be contacted.

**A common sense approach usually resolves the issue.**

## **GENERAL RULES**

1. For all secured worksites, contracted workers are required to sign in and sign out each day
2. (Access cards may be issued – a worker may need to provide an Identification document (i.e., Driver's License) in exchange).

3. Personal protective equipment, as determined by the City, through consultation with the Contractors Health and Safety Representatives must be worn when and where required. (Hard Hats, Safety Footwear, Safety Vests and Safety Glasses must be worn on active construction sites. Hearing Protection must be worn when noise levels are above 85dBA.)
4. Horseplay, gambling and the use of alcohol or narcotics will not be tolerated.
5. No Smoking within 7.5M of a City owned buildings door exits, windows and vents.
6. Report **ALL** injuries to your supervisor immediately and notify the City's site representative.
7. Report any unsafe conditions, including someone under the influence or hazards, which may allow an injury to occur to you, a fellow worker, or others on the worksite.
8. Report any property damage, regardless of how minor.
9. Restricted and controlled products will be labeled, used and stored in accordance with the associated regulations, e.g., WHMIS. Follow all procedural instructions when using or handling hazardous materials/controlled products and ensure that all containers of hazardous/controlled product materials are properly labelled and stored in designated areas.
10. Obey all posted signs and notices. Do not venture into areas that you are not authorized to enter.
11. Always use the correct posture when lifting and get assistance if the weight is excessive.
12. Do not work within the limits of approach to high voltage equipment.
13. If working at heights greater than 10 feet a Fall Protection system must be in place. The appropriate Fall Protection equipment must be worn at all times.
14. **Housekeeping** (Orderliness and good housekeeping are basic requirements and must be maintained at all times):
  - a) Aisles are to be kept clear at all times.
  - b) Individual work areas are to be kept clean and tidy.
  - c) All materials, tools, products and equipment are to be kept in their designated areas.
  - d) Liquid spills are to be cleaned up immediately to prevent slips and falls.
  - e) Accumulation of oily rags, combustible refuse or similar fire hazards will not be tolerated.
15. **Fire Prevention:**
  - a) Become familiar with Surroundings and emergency exit.
  - b) Ensure aisles and exits are not blocked at any time.
  - c) Anytime a fire extinguisher is used, report it immediately to your supervisor, so that it can be recharged.
16. **Equipment Operation** (Any equipment, which could create a hazard, must be maintained in good condition):
  - a) Equipment must not be repaired, adjusted or operated unless by a "competent person" who understand the safe operating procedures.
  - b) Always be aware of the use and location of the "EMERGENCY STOP" button, if equipment is so equipped, before using the equipment.
  - c) Loose clothing, jewelry and long hair must be secured to prevent becoming entangled with equipment.

- d) The Operator must check all safety devices on equipment before operation.
  - e) All equipment must be turned off and the appropriate "lock-out" procedure followed, prior to repairs, cleaning, adjustment or lubrication.
  - f) Radio/Walkman/I-pod Headphones are not allowed to be worn during regular work operations.
  - g) All ladders must be of an approved type and length. Unacceptable ladders must be removed immediately from the premises.
  - h) All vehicles and equipment on City property must be kept in safe mechanical condition at all times, and be operated only by persons with a valid driver's license and/or proper training and qualifications.
  - i) Contractors will not operate any equipment, valves, switches, etc., which are part of the City's operation, unless specific permission is received from the Department Representative.
17. **Ground Disturbance** –Every time you dig in the ground, with a shovel or mechanized equipment, you run the risk of loss of life or damage to property if you hit any of the many buried cables, conduits, gas or oil pipelines and/or other underground facilities that serve our city, **BC One Call Must be called and a ticket obtained prior to commencing any ground disturbance activities.**

<b>Issued By:</b>	<b>Occupational Health &amp; Safety Section - Contractor Coordination Program</b>
<b>Date:</b>	<b>Revised: January 14, 2014    Original: August 15, 2014</b>
<b>Distributed:</b>	<b>Via Email &amp; Posted on Intranet: January 16, 2015: <u>August 15, 2014</u></b>

**This document does not replace the Workers' Compensation Act or WorkSafeBC OH&S regulation. Each individual Contractor must have specific health and safety safe work rules and procedures that apply to their work tasks. Each Contractor must comply with the Workers' Compensation Act and WorkSafeBC Occupational Health & Safety Regulation and to all federal, provincial and local laws and regulations. If a contractor is unable to comply they must bring this to the attention of their qualified safety representative and to the Prime Contractor safety representative immediately.**

**Authorized Signature:** \_\_\_\_\_

**Name:** \_\_\_\_\_

**(Please Print)**

**Date:** \_\_\_\_\_



**ATTACHMENT 4**

**COVID-19 PRE-WORK CONTRACTOR ORIENTATION CHECKLIST**



**HEALTH AND SAFETY**

**Enhanced Screening Questions Acknowledgement**

The contractor must answer the following questions

YES	NO	Question
<input type="checkbox"/>	<input type="checkbox"/>	Have you been advised by the public health authority or your family physician to self-monitor or self-isolate?
<input type="checkbox"/>	<input type="checkbox"/>	Do you have any of the following symptoms: Fever Cough Sore throat Difficulty breathing Pneumonia
<input type="checkbox"/>	<input type="checkbox"/>	Have you just returned from outside of Canada within the last 14 days?
<input type="checkbox"/>	<input type="checkbox"/>	Were you on a cruise ship within the last 14 days?
<input type="checkbox"/>	<input type="checkbox"/>	Have you been in close contact with a person who has been confirmed with coronavirus (COVID-19) (family or friend that you live with)?

In the event that a contractor/worker becomes ill onsite, the contractor/worker must immediately leave the City of Surrey building and notify the Site Supervisor (Phone Number: \_\_\_\_\_)

I hereby acknowledge receipt of information on requirement for the Safety and Health at City of Surrey and will adhere to the terms set herein and cooperate with all policies and procedures.

**Printed Name:** \_\_\_\_\_

**Contractor Company Name:** \_\_\_\_\_

**Facility /Location:** \_\_\_\_\_

**Employee/Contractor Signature** \_\_\_\_\_ **Date:** \_\_\_\_\_

A healthy and safe workplace is everyone's responsibility. Your active participation and support are vitally important to maintaining and improving health and safety in our workplace.